

LunaNet Interoperability Specification Document

Version 4

TABLE OF CONTENTS

Tables and Figures	4
List of To Be Determined and To Be Refined	5
1. Introduction	11
1.1 Purpose	11
1.2 Scope	12
1.3 Security Considerations	12
2. LunaNet Interoperability Overview.....	13
3. User Services	15
3.1 Communications Services	15
3.1.1 Real-Time Communications Services.....	16
3.1.2 Store-and-Forward Communications Services	17
3.1.3 Messaging Services	18
3.2 Position, Navigation, and Timing Services	20
3.2.1 Reference Signals	22
3.2.2 Lunar Augmented Navigation System (LANS)	23
3.2.3 One-Way Measurements	25
3.2.4 Two-Way Measurements	26
3.2.5 Two-Way Transponder	27
3.2.6 Supplemental Navigation Products (Nav-Supp)	28
3.2.7 Location Service (Loctn).....	29
3.3 Detection and Information Services	29
3.3.1 Lunar Search and Rescue (LunaSAR) Services.....	30
3.3.2 Space Weather Alerting Services.....	31
3.4 Science Services	31
3.5 Service Access	32
3.5.1 Earth-based Scheduling Service.....	32
4. LunaNet Service Provider to User Interfaces	34
4.1 LNSP-User Lunar Surface Interfaces.....	35
4.2 LNSP-User Proximity Interfaces	36
4.3 LNSP-User DTE Interfaces	43
4.4 LNSP-User Terrestrial Interfaces	46
5. LunaNet Service Provider to LunaNet Service Provider Services.....	46
5.1 LNSP A-LNSP B Communications Services.....	46
5.2 LNSP A-LNSP B PNT Services	46
6. LunaNet Service Provider to LunaNet Service Provider Interfaces.....	47
6.1 LNSP A-LNSP B Lunar Surface Interfaces.....	47

6.2 LNSP A-LNSP B Crosslink Interfaces	47
6.3 LNSP A-LNSP B DTE Interfaces	48
6.4 LNSP A-LNSP B Terrestrial Interfaces	48
References	49
Applicable Documents	50
Appendix A. LunaNet Interoperability Specification Phase Allocations	52
Appendix B. Acronyms and Abbreviations.....	54
Appendix C. Detailed Signal Definitions.....	56
Augmented Forward Signal Structure (PFS5).....	56
Multiple Access Return Signal Structure (PRS5)	57
Appendix D. LunaNet Application Messages	59
Overview of Messages	59

Tables and Figures

<i>Table 1 - Lunar Network Service Provider Interfaces</i>	15
<i>Table 2 - IP Service Interfaces</i>	17
<i>Table 3 - Bundle Protocol Service Interfaces</i>	17
<i>Table 4 - Messaging Services Interfaces</i>	18
<i>Table 5 - Message ID and Titles</i>	19
<i>Table 6 - Detection and Information Services</i>	29
<i>Table 7 - LNSP–User Lunar Surface-Surface Link Layer Service Interfaces</i>	35
<i>Table 8– LNSP–User Proximity Link Layer Service Interfaces</i>	36
<i>Table 9 - Coding and Framing of Proximity Signals</i>	41
<i>Table 10 - LNSP–User Direct to Earth Link Layer Service Interfaces</i>	43
<i>Table 11 - Codeword/Message Size for signals in Table 10</i>	46
<i>Table 12 - LNSP–User Terrestrial Link Layer Service Interfaces</i>	46
<i>Table 13 - LNSP–LNSP Crosslink Layer Interfaces (TBD)</i>	47
<i>Figure 1 - LunaNet Segments</i>	13
<i>Figure 2 - LunaNet Standard Services and Interfaces between LNSPs and Users</i>	14
<i>Figure 3 - LunaNet Service Providers Interfaces</i>	14
<i>Figure 4 - Three Types of Communications Services</i>	16
<i>Figure 5 – User Application Simplified Protocol Stack</i>	16
<i>Figure 6 - LunaNet Applications Simplified Protocol Stack</i>	18
<i>Figure 7 - LunaNet Node and user exchange messages using messaging services</i>	19
<i>Figure 8 - PNT Services Provided by LunaNet</i>	22
<i>Figure 9 - Reference PNT Signals Provided by a LunaNet Node</i>	22
<i>Figure 10 - LANS PNT Concept Provided by LunaNet Nodes</i>	24
<i>Figure 11 - LANS IOC Service Coverage and Performance Volume</i>	25
<i>Figure 12 - LANS EOC Service Coverage and Performance Volume</i>	25
<i>Figure 13 - One-Way Measurements Performed by a LunaNet Node</i>	26
<i>Figure 14 - Two-Way Measurements Performed by LunaNet Node</i>	27
<i>Figure 15 – Two-Way LunaNet Node Transponder</i>	27
<i>Figure 16 - LunaSAR Data Path ConOps</i>	30
<i>Figure 17 - LunaNet Scheduling Interfaces Overview</i>	32
<i>Figure 18 - Augmented Forward Signal Service Provided by a Single LunaNet Source</i>	33
<i>Figure 19 - Functional Interfaces and Corresponding Frequency Bands</i>	34
<i>Figure 20- LunaNet Interoperability Frequency Plan</i>	35

List of To Be Determined and To Be Refined

The table below lists specific To Be Determined (TBD) and To Be Refined (TBR) items in the LNIS document. These items are yet to be finalized or currently undefined at the release of this version.

Each designator is numbered based on the document title, document version number when TBD/TBR was identified, designation of TBD or TBR, parent section number, and number of the particular unresolved item. For example, “LNIS4-TBD-6004” can be dissolved as – 4th unresolved TBD item identified in LunaNet Interoperability Specification Version 4 Section 6. Once each item is dispositioned, the resolution will be substituted in place of the designator and the item will be struckthrough (~~LNIS4-TBD-6004~~) in this table. If new unresolved items are identified, it will be added to this table using the above defined designation scheme. All TBD/TBR will retain its original numbers and will not be renumbered as items are added or deleted.

List of TBDs/TBRs

Designation	Section	Description
LNIS4-TBD-3001	3.1.2 /Table 3 - Bundle Protocol Service Interfaces	Applicable document needed for Bundles / TCPCL. Bundles are forwarded via TCP convergence layer adapter over TCP/IP.
LNIS4-TBD-3002	3.1.2 /Table 3 - Bundle Protocol Service Interfaces	Applicable document needed for Bundles / UDPCL - Bundles are forwarded via UDP convergence layer adapter over UDP/IP.
LNIS4-TBD-3003	3.1.3/ Table 4 - Messaging Services Interfaces	Applicable document needed for Message over Link. Messages inserted directly into AOS frames for transfer over a single link.
LNIS4-TBD-3004	3.1.3/ Table 4 - Messaging Services Interfaces	Applicable document needed for Message over IP. Messages inserted into IP packets to allow for multiple IP hops to IP destination.
LNIS4-TBD-3005	3.1.3/ Table 4 - Messaging Services Interfaces	Applicable document needed for Message over DTN. Messages inserted into DTN bundles to allow for multiple hops to any LunaNet destination.
LNIS4-TBD-3006	3.1.3/ Table 4 - Messaging Services Interfaces	Applicable document needed for Message over AFS. Messages transmitted over the Augmented Forward Signal (AFS) may be carried in a unique manner to accommodate the low AFS data rate.
LNIS4-TBD-3007	3.2.1.2 Pseudo-Range and Timing Reference (1wRTRef)	PN codes as identified in CCSDS 414.1-B-2 and CCSDS 415.1-B-1 have traditionally been employed for two-way ranging purposes. To use them as an option for one-way measurements, a method (TBD) must be set in place to convey information to the user correlating source PN phasing and the corresponding time of transmission.
LNIS4-TBD-3008	3.2.1.3 Time-Transfer Reference (Tref)	A standardized method (TBD) for a LunaNet node to provide a time reference will be implemented to allow users to have accurate time.

LNIS4-TBD-3009	3.2.4.2 Range Measurement (2wRMeas)	Frame ranging involves timestamping and identification of synchronized information frames. It is particularly useful in high-rate communications links, where elevated data frame rates facilitate more accurate time resolution. A frame ranging standard is TBD.
LNIS4-TBD-3010	3.2.5.2 Non-Regenerative Range Transponder (2Wnrr-XPND)	In addition to what is performed for the two-way Doppler transponder service, a non-regenerative LunaNet transponder filters and re-modulates the ranging signal onto the forward signal. The LunaNet provider does not require knowledge of the ranging signal type employed by the user. The bandwidth allocated to the ranging signal and used by the LunaNet provider for filtering shall be TBD.
LNIS4-TBD-3011	3.2.6.1 Lunar Reference Frame	The use of a common lunar-centered, selenocentric reference frame across LunaNet PNT services enables seamless consumption of the services, irrespective of specific LNSP or users. The lunar reference frame is described in detail in Lunar Reference Frame Standard (TBD).
LNIS4-TBD-3012	3.2.6.2 Lunar Reference Time	The use of a common lunar reference time across LunaNet elements is required to enable synchronization of services and time in the lunar domain. This common lunar reference time is described in detail in Lunar Time System Standard (TBD).
LNIS4-TBD-3013	3.3.1 Lunar Search and Rescue (LunaSAR) Services	The distress message might include the position of the beacon (if determined through the LunaNet PNT services) or the beacon position might be computed by the LNSP (or another actor) via triangulation of the beacon as received by multiple LunaNet nodes. A beacon might not know where the LNSP satellites are and might not have directive antenna capabilities, so the distress message might be broadcast and arrive at the LNSP with low power, this might require a dedicated, protected band, TBD.
LNIS4-TBD-3013	3.3.2 Space Weather Alerting Services	Space Weather alerts and related messages will be communicated using the messaging services, per Appendix D. The specific standard alert and message content are still TBD.
LNIS4-TBD-3014	3.5.2.3 User Initiated Services	User Initiated Services (UIS) may be implemented through service acquisition protocols incorporating messages using the messaging services or through a hailing approach. Standards for both approaches are TBD.
LNIS4-TBD-4001	4.0 Lunanet Service Provider To User Interfaces	Standards for optical link interfaces are TBD.
LNIS4-TBD-4002	4.1 LNSP-User Lunar Surface Interfaces	LS3 - Short-to-medium range wireless network with mobility and roaming utilizing 3GPP rel. 16 (and higher) (LTE and 5G TBD).
LNIS4-TBD-4003	4.1 LNSP-User Lunar Surface Interfaces	Target Frequency Range is TBD for LS3, Short-to-medium range wireless network with mobility and roaming.
LNIS4-TBD-4004	4.2 / Table 8 – LNSP–User Proximity Link Layer Service Interfaces	Proximity Forward S-band Medium Rate w/ Ranging (PFS2) 2025-2110 MHz - Fixed frequency assignments TBD.

LNIS4-TBD-4005	4.2 / Table 8 – LNSP–User Proximity Link Layer Service Interfaces	Proximity Forward S-band Medium Rate w/ Ranging (PFS2) 2025-2110 MHz - Symbol & Chip Rates TBD.
LNIS4-TBD-4006	4.2 / Table 8 – LNSP–User Proximity Link Layer Service Interfaces	Proximity Return S-Band CDMA Return (PRS2) 2200-2290 MHz - Fixed frequency assignments TBD.
LNIS4-TBD-4007	4.2 / Table 8 – LNSP–User Proximity Link Layer Service Interfaces	Proximity Return S-Band CDMA Return (PRS2) 2200-2290 MHz - Symbol & Chip Rates TBD.
LNIS4-TBD-4008	4.2 / Table 8 – LNSP–User Proximity Link Layer Service Interfaces	Proximity Return S-Band CDMA Return (PRS5) 2200-2290 MHz Fixed frequency assignments TBD.
LNIS4-TBD-4009	4.2 / Table 8 – LNSP–User Proximity Link Layer Service Interfaces	Proximity Return S-Band CDMA Return (PRS5) 2200-2290 MHz Symbol & Chip Rates TBD.
LNIS4-TBD-4010	4.2 / Table 8 – LNSP–User Proximity Link Layer Service Interfaces	Proximity Forward Ka-band Data Only (PFKa1) 23.15-23.55 GHz $1 \text{ Msps} \leq R_s \leq \text{TBD}$
LNIS4-TBD-4011	4.2 / Table 8 – LNSP–User Proximity Link Layer Service Interfaces	Proximity Forward Ka-band Variable Coding and Modulation (PFKa2) 23.15-23.55 GHz $1 \text{ Msps} \leq R_s \leq \text{TBD Msps}$ [6]
LNIS4-TBD-4012	4.2 / Table 8 – LNSP–User Proximity Link Layer Service Interfaces	Proximity Forward Ka-band High-Rate Data Only (PFKa3) 23.15-23.55 GHz $1 \text{ Msps} \leq R_s \leq \text{TBD Msps}$ [6]
LNIS4-TBD-4013	4.2 / Table 8 – LNSP–User Proximity Link Layer Service Interfaces	Proximity Forward Ka-band High-Rate Data w/ Ranging (PFKa4) 23.15-23.55 GHz $1.5 \text{ Msps} \leq R_s \leq \text{TBD Msps}$ [6], [8]
LNIS4-TBD-4014	4.2 / Table 8 – LNSP–User Proximity Link Layer Service Interfaces	Proximity Return Ka-band Data Only (PRKa1) 27.0-27.5 GHz $1 \text{ Msps} \leq R_s \leq \text{TBD Msps}$ [6]
LNIS4-TBD-4015	4.2 / Table 8 – LNSP–User Proximity Link Layer Service Interfaces	Proximity Return Ka-band Variable Coding and Modulation (PRKa2) 27.0-27.5 GHz $1 \text{ Msps} \leq R_s \leq \text{TBD Msps}$ [6], [8]
LNIS4-TBD-4016	4.2 / Table 8 – LNSP–User Proximity Link Layer Service Interfaces	Proximity Return Ka-band High-Rate Data Only (PRKa3) 27.0-27.5 GHz $1 \text{ Msps} \leq R_s \leq \text{TBD Msps}$ [6]
LNIS4-TBD-4017	4.2 / Table 8 – LNSP–User Proximity Link Layer Service Interfaces	Proximity Return Ka-band Data w/ Ranging (PRKa4) 27.0-27.5 GHz $1.5 \text{ Msps} \leq R_s \leq \text{TBD Msps}$ [6]
LNIS4-TBD-4018	4.2 / Table 9 - Coding and Framing of Proximity Signals	PFS/PRS 1e coding is TBD
LNIS4-TBD-4019	4.2 / Table 9 - Coding and Framing of Proximity Signals	PFS/PRS 1e frequency and rate is TBD

LNIS4-TBD-4020	4.2 / Table 9 - Coding and Framing of Proximity Signals	PFS/PRS5 frequency and rate is TBD
LNIS4-TBD-4021	4.3 / Table 10 - LNSP–User Direct to Earth Link Layer Service Interfaces	Ka-band Uplink High Rate Data Only (KaU1) Frequency Range & Symbol Rate - 22.55-23.15 GHz $2 \text{ Msps} \leq R_s \leq 50 \text{ Msps}$ (Upper Limit TBD)
LNIS4-TBD-4022	4.3 / Table 10 - LNSP–User Direct to Earth Link Layer Service Interfaces	Ka-band Uplink High Rate Data Only (KaU2) Frequency Range & Symbol Rate 22.55-23.15 GHz $2 \text{ Msps} \leq R_s \leq 50 \text{ Msps}$ (Upper Limit TBD)
LNIS4-TBD-4023	4.3 / Table 10 - LNSP–User Direct to Earth Link Layer Service Interfaces	Ka-band Downlink High Rate Data Only (KaD1) 25.5-27.0 GHz $2 \text{ Msps} \leq R_s \leq 200 \text{ Msps}$ [Upper Limit TBD], See note [4]
LNIS4-TBD-4024	4.3 / Table 10 - LNSP–User Direct to Earth Link Layer Service Interfaces	Ka-band Downlink High Data w/ Ranging (KaD2) 25.5-27.0 GHz $2 \text{ Msps} \leq R_s \leq 200 \text{ Msps}$ (Upper Limit TBD) See note [4]
LNIS4-TBD-4025	4.3 / Table 10 - LNSP–User Direct to Earth Link Layer Service Interfaces	Note [3] Applicable document for some signals are TBD. Standards development is an ongoing effort.
LNIS4-TBD-6001	6.2 / Table 13 - LNSP–LNSP Crosslink Layer Interfaces	CFKa1 Crosslink Forward Targeted Frequency Range is TBD 23.15 – 23.55 GHz (TBD)
LNIS4-TBD-6002	6.2 / Table 13 - LNSP–LNSP Crosslink Layer Interfaces	CRKa1 Crosslink Return Targeted Frequency Range is TBD 27.00 – 27.50 GHz (TBD)
LNIS4-TBD-AD0001	Applicable Documents	[AD1] LunaNet and User Signal Structure Definition Document (TBD)
LNIS4-TBD-AD0002	Applicable Documents	[AD2] LunaNet Measurement Schema and Parameters Document (TBD)
LNIS4-TBD-AD0003	Applicable Documents	[AD3] LunaNet Detailed Message Definition Document (TBD)
LNIS4-TBD-AD0004	Applicable Documents	[AD4] LunaNet Location Services for Users Document (TBD)
LNIS4-TBD-AD0005	Applicable Documents	[AD5] Lunar Reference Frame Standard (TBD)
LNIS4-TBD-AD0006	Applicable Documents	[AD6] Lunar Time System Standard (TBD)
LNIS4-TBD-AD0007	Applicable Documents	[AD7] LunaNet LunaSAR Definition Document (TBD)
LNIS4-TBD-AD0008	Applicable Documents	[AD8] LunaNet Interoperability Security Specifications (TBD)

LNIS4-TBR-3001	3.3.1 Lunar Search and Rescue (LunaSAR) Services	LunaSAR's distress alert service is potentially received on PRS5 [TBR] and responded to over the PFS5 [TBR] links and are prioritized for rebroadcasting when received by the LunaNet orbiting asset(s).
LNIS4-TBR-4001	4.1 / Table 7 - LNSP–User Lunar Surface-Surface Link Layer Service Interfaces	For LS1 Short-range wireless network Targeted Frequency Range 5.150-5.835 GHz (Lunar Near-side use only) (TBR) under study.
LNIS4-TBR-4002	4.2 / Table 8– LNSP–User Proximity Link Layer Service Interfaces	Proximity Forward S-Band Medium Rate w/ Ranging (PFS1b) Chip rate TBR
LNIS4-TBR-4003	4.2 / Table 8– LNSP–User Proximity Link Layer Service Interfaces	Proximity Forward S-Band Medium Rate w/ Ranging (PFS1b) See Note [1] See CCSDS 401.0-B Section 2.2.7 for explanation of PCM/PM/bi-phase-L.TBR: supplemental reference for implementation of PN ranging. Presence of residual carrier aids demodulation (e.g. large doppler dynamics scenarios).
LNIS4-TBR-4004	4.2 / Table 8– LNSP–User Proximity Link Layer Service Interfaces	Proximity Forward S-Band Low Rate w/ Ranging (PFS1c) See Note [1] See CCSDS 401.0-B Section 2.2.4 for explanation of PCM/PSK/PM. TBR: supplemental reference for implementation of PN ranging. Presence of residual carrier aids demodulation (e.g., large doppler dynamics scenarios).
LNIS4-TBR-4005	4.2 / Table 8– LNSP–User Proximity Link Layer Service Interfaces	Proximity Forward S-band Medium Rate w/ Ranging (PFS2) SS-BPSK CDMA (~3Mcps) or SS-UQPSK TBR.
LNIS4-TBR-4006	4.2 / Table 8– LNSP–User Proximity Link Layer Service Interfaces	Proximity Return S-Band Medium Rate w/ Ranging (PRS1b) Chip rate TBR
LNIS4-TBR-4007	4.2 / Table 8– LNSP–User Proximity Link Layer Service Interfaces	Proximity Return S-Band Medium Rate w/ Ranging (PRS1b) See Note [1] See CCSDS 401.0-B Section 2.2.7 for explanation of PCM/PM/bi-phase-L. TBR: supplemental reference for implementation of PN ranging.
LNIS4-TBR-4008	4.2 / Table 8– LNSP–User Proximity Link Layer Service Interfaces	Proximity Return S-Band CDMA Return (PRS2) SS-SQPN TBR.
LNIS4-TBR-4009	4.2 / Table 8– LNSP–User Proximity Link Layer Service Interfaces	Proximity Return S-Band CDMA Return (PRS2) See Note [2] Intent is for a wide beam spread spectrum return intended for P2P links. Similar to PRS5 but allows for higher data rates (less spreading) and ranging. There is a possibility to support multiple users simultaneously, albeit much less than PRS5. Signal parameters could also be modified for user specific needs (TBR).
LNIS4-TBR-4010	4.2 / Table 8– LNSP–User Proximity Link Layer Service Interfaces	Proximity Return S-Band CDMA Return (PRS5) SS-BPSK CDMA (~3Mcps) or SS-UQPSK(Appendix C) TBR.

LNIS4-TBR-4011	4.2 / Table 9 - Coding and Framing of Proximity Signals	PFS/PRS 1b uncoded is TBR
LNIS4-TBR-4012	4.2 / Table 9 - Coding and Framing of Proximity Signals	PFS/PRS 1d uncoded is TBR
LNIS4-TBR-AP0001	Detailed Signal Definitions / Augmented Forward Signal Structure (PFS5)	To transmit a carrier center frequency of 2492.028 MHz, the reference clock can be at 1.023MHz utilizing a reference clock multiplier of 2436. The detailed definition of the signal is provided in LunaNet and User Signal Structure Definition Document [AD1]. The AFS data rate is expected to be between 250sps and 1ksps (TBR).

1. INTRODUCTION

LunaNet is envisioned as a set of cooperating networks providing communications, navigation, and other services for users on and around the Moon. The LunaNet concept is based on a framework of mutually agreed-upon standards, protocols, and interface specification that enable interoperability. LunaNet is intended to allow many lunar mission users to engage the services of diverse commercial and government service providers in an open and evolvable architecture. LunaNet services can include communications, messaging, data transmission and distribution of position, navigation, timing, and situational awareness information. The LunaNet concept can be introduced as part of the earliest missions and accommodate expansion as new users and service providers come online. Many nations, agencies, and private companies can contribute to and participate in the establishment and operation of LunaNet.

This document, along with its companion documents, provides the basis for a comprehensive set of specifications for operation of a lunar communications and navigation network capable of interoperating with other networks compliant with the Lunar Network (LunaNet). LunaNet will include Earth ground stations and orbiting spacecraft and will provide services to a variety of missions including those for human exploration, lunar science, and space technology.

LunaNet will start with a simple architecture of a few nodes to meet the needs of the early missions and evolve to meet the growing needs of a sustained lunar presence. All relay network services are not expected to be met by a single spacecraft, or node. The expectation is that the needs of users will be met through a combination of interoperable systems supplied by commercial and government providers. Interoperability across this network-of-networks can be achieved through negotiation of mutually-agreed-upon standards that will be reflected in this document and in the specifications defined by other participants in the cooperative lunar network.

This current version of the document was written and reviewed by NASA and the European Space Agency (ESA).

1.1 Purpose

The purpose of this specification is to define the standard services and interfaces for LunaNet service providers to administer interoperable services to meet the needs of missions operating in the lunar vicinity. This document is not intended to replace either the International Communication System Interoperability Standards (ICSIS) or the Interagency Operations Advisory Group's (IOAG) Lunar Communications Architecture Documents. This document provides the minimum set of standard services and interfaces that will be available to lunar users, such that users may design their systems with the expectation of available providers. Any individual provider is not required to offer all services and interfaces in this document, but the aggregation of providers will have the interfaces and services described. It is also possible for providers to offer services and interfaces beyond what is described in this document. However, those services and interfaces will likely not be interoperable between service providers, thereby limiting the service options for a user.

This current document captures all services and needs for LunaNet, as currently identified. These needs are expected to be met through a consortium of providers. To the extent that service providers follow the mutually-agreed-upon standards for the services and interfaces, which are reflected in this and applicable documents, the combined network can provide seamless services to multiple users.

Appendix A contains a table allocating these specifications to two operational time periods. These time periods are Initial Operations Capability (IOC) phase and Sustained Capability phase. The IOC intends to incorporate those requirements to support the first Artemis missions and robotic missions with the lunar south pole and lunar far side as primary locations of interest. The evolution towards the sustained capability will be aligned with the plans for the increased human and robotic lunar missions.

1.2 Scope

This document defines the standards and specifications for interoperations within LunaNet on the lunar surface and in cislunar space. NASA is seeking international and commercial inputs to reach consensus on the contents of this document.

This document will provide the necessary guidance for potential providers and users to design and build systems compatible with the broad LunaNet architecture. These standards and specifications are intended for broad use by all parties operating in cislunar space and will be levied as requirements on systems and services required to be interoperable.

1.3 Security Considerations

This section should be considered an informational reference as the LunaNet architecture and associated security continues to mature and the international community further defines interoperable security requirements. A LunaNet Interoperability Security Specifications [AD8], referenced at the end of this section, will be the repository for detailed implementation specifications.

There are general expectations that Users and Providers shall protect the confidentiality, integrity, and availability of the systems, data, and communication pathways that will be part of LunaNet. These protections should be ensured using a combination of software and hardware that prevents unauthorized access, as well as corruption, interception, and loss of data.

NIST Definitions for clarity:

- Confidentiality - Defined as preserving authorized restrictions on information access and disclosure, including ensuring the means for protecting personal privacy and proprietary information from access and disclosure.
- Integrity - Defined as guarding against improper information modification or destruction and includes ensuring information non-repudiation and authenticity.
- Availability - Defined as ensuring timely and reliable access to and use of information.

Users are expected to protect their data through encryption and authentication mechanisms appropriate to the type of data they are transmitting and/or receiving. All user protocols with security enhancements will be required to comply with communications standards outlined in this document and shall not result in architectural changes to LunaNet.

Network layer services, including but not limited to, Internet Protocol and Bundle Protocol will be natively supported by LunaNet; this includes end-to-end data transport using IPSEC and BPSec. All other data transport methods may be considered for approval with appropriate secure interfaces on a case-by-case basis for consideration and inclusion in the LunaNet Interoperability Specification.

LunaNet relays and nodes shall capture and transmit updated availability status and configuration controls to enable rapid response to facilitate troubleshooting any communications anomalies.

[AD8]: LunaNet Interoperability Security Specifications is under development. Once approved, this will be the authoritative source for interoperable LunaNet security requirements.

2. LUNANET INTEROPERABILITY OVERVIEW

The term “LunaNet” encompasses all systems that provide communications and navigation (or position, navigation, and timing (PNT)) services to user systems on and around the Moon (User Lunar Segment) and the users’ associated systems on Earth (User Earth Segment). As seen in Figure 1, LunaNet has a Lunar Segment and an Earth Segment. The Lunar Segment contains elements that could either be in lunar orbit or on the lunar surface. Though they may be referred to in general as “lunar relays,” it is possible that some elements of the Lunar Segment may not provide any communications relay functions, but support PNT or other non-data relay functions.

The User Lunar Segment may interface with LunaNet by either an interface with the LunaNet Lunar Segment or with the LunaNet Earth Segment. The LunaNet Earth Segment is comprised of ground stations on Earth. Note that there are also interfaces between the LunaNet Lunar Segment and the LunaNet Earth Segment, these may be either intra-network, i.e., within a network provided by a single provider, or it may be inter-network, i.e., between cooperating providers. Standardization of the Lunar Relay-Earth Interface will enable the inter-network or cross support of lunar relays by multiple providers. The Lunar Relay-Earth Interface, shown in Figure 1, is an intra-network example and the single provider in this case may use a non-standardized interface. The LunaNet Lunar Relay-User Interface and LunaNet-Direct-to-Earth Interface are standardized. The interface between the LunaNet Earth Segment and the User Earth Segment will also be standardized. Note that the user could provide a private direct link between its lunar and Earth segments. This is outside the scope of LunaNet and is not addressed in this specification.

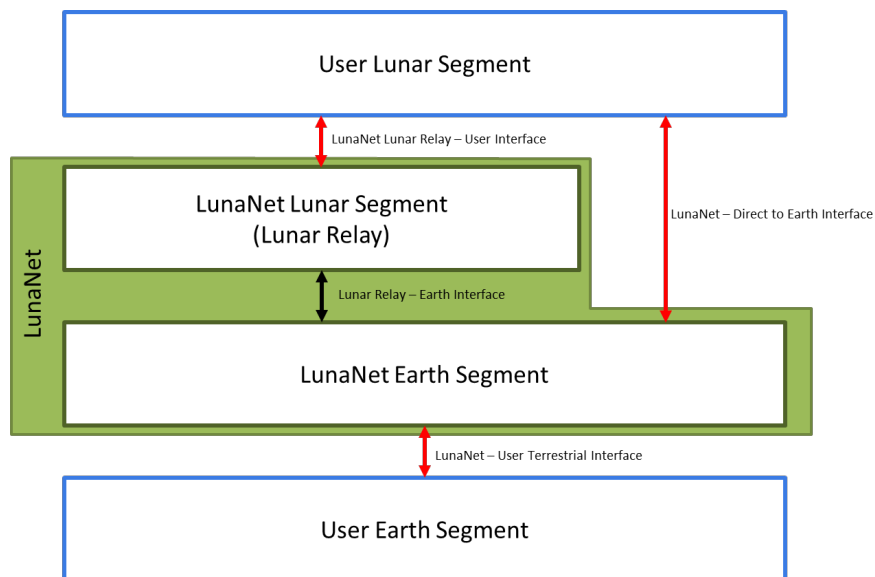

Figure 1 - LunaNet Segments

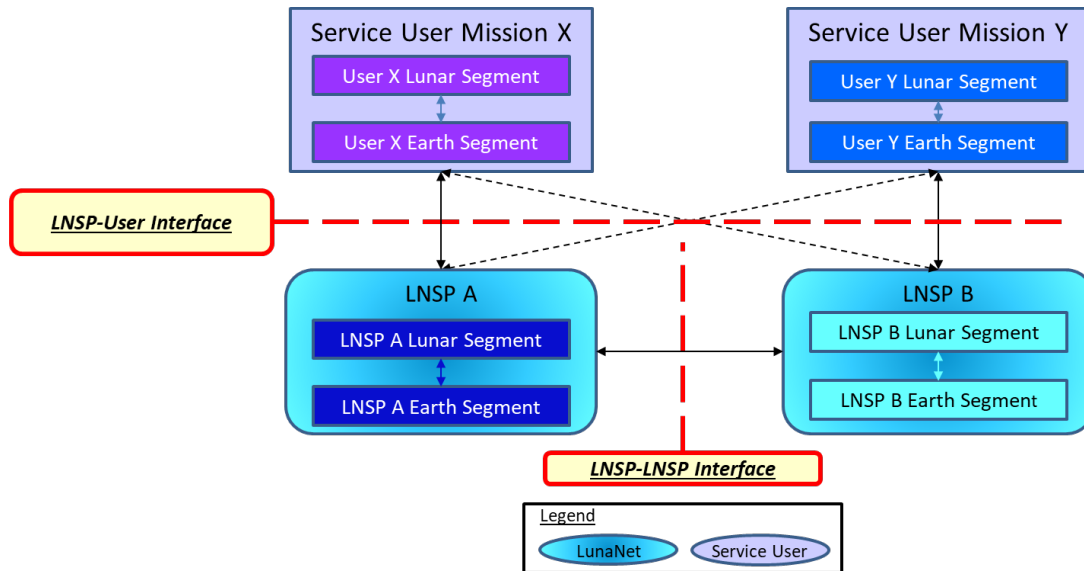

Figure 2 - LunaNet Standard Services and Interfaces between LNSPs and Users

Like the terrestrial internet, LunaNet will be built up through multiple LunaNet Service Providers (LNSPs) combined to provide services to users. To allow users to receive those services from any provider such that it appears as a single provider to that individual user, two categories of interoperable interfaces are required (See Figure 2).

The first category is the LNSP-User Interface, which include the service interfaces between a user and a provider. These include both the physical interfaces and the protocols and messages that provide services over those interfaces. A user shall be able to operationally receive the same service from different providers in the same way, such that the user will be able to use any connection as a LunaNet access point.

The second category is the LNSP – LNSP Interface. These include the physical interfaces and protocols and the messages that allow different LNSPs to work together to provide the larger LunaNet infrastructure by augmenting individual LNSP capabilities with LNSP partners.

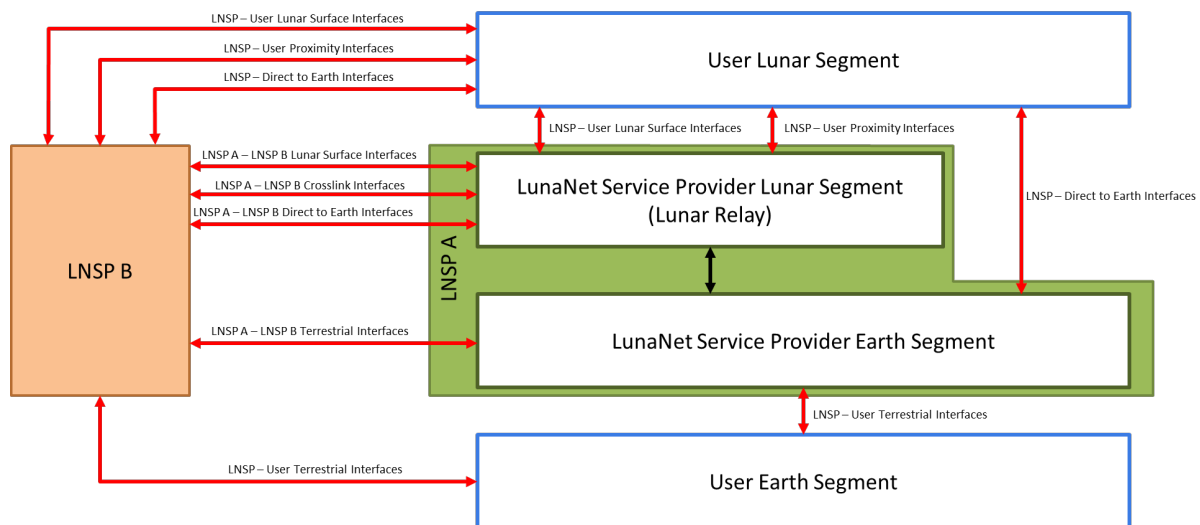

Figure 3 - LunaNet Service Providers Interfaces

The LNSP interfaces are depicted in Figure 3. Each LNSP may have any combination of lunar surface, proximity, direct-to-Earth, and terrestrial interfaces with users. Interfaces between LNSPs may be any combination of lunar surface, crosslink, direct-to-Earth, and terrestrial interfaces. Lunar surface interfaces are interfaces between a LNSP lunar surface node and a user surface node. Proximity interfaces are between a LNSP lunar orbiting node and an orbiting or surface node.

Table 1 - Lunar Network Service Provider Interfaces

Interface Name	Interface Description	Document Section
LNSP-User Lunar Surface Interfaces	Surface to surface interfaces between user and provider	4.1
LNSP-User Proximity Interfaces	User interfaces with lunar orbiting provider nodes	4.2
LNSP-User DTE Interfaces	Interfaces between user lunar systems and provider earth systems	4.3
LNSP-User Terrestrial Interfaces	Terrestrial interfaces between user and provider	4.4
LNSP A-LNSP B Lunar Surface Interfaces	Surface to surface interfaces between two LNSPs	6.1
LNSP A-LNSP B Crosslink Interfaces	Interfaces between two LNSP's lunar orbiting nodes	6.2
LNSP A-LNSP B DTE Interfaces	Interfaces between an LNSP lunar system and a different LNSP earth system	6.3
LNSP A-LNSP B Terrestrial Interfaces	Terrestrial interfaces between two LNSPs	6.4

This document identifies the standards to be used for the physical and service interfaces described above and depicted in red in Figure 3.

3. USER SERVICES

3.1 Communications Services

There are three communications service types (see Figure 4). Real-time data services provide end-to-end data delivery between source and destination with minimal delay. The latency on these services will be due to the signal travel time, any channel coding, and data operations only. Store-and-forward data services provide end-to-end data delivery with additional latency incurred by storage of data along the end-to-end path. This storage allows for the delivery of data when discontinuities or significant rate buffering occurs along the path. Messaging services provide a means to send standardized messages from LunaNet protocols or applications over specified LunaNet message channels within communications services, while abstracting the specifics of those services from the messaging application.

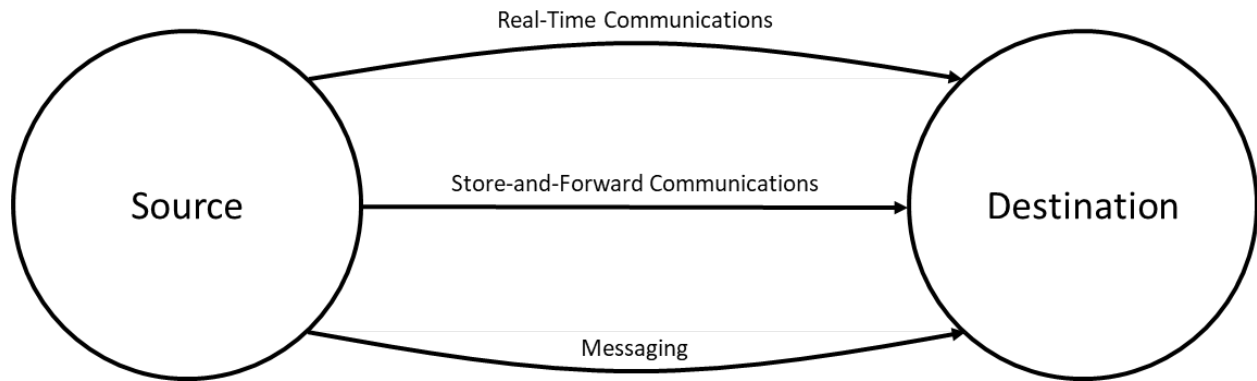

Figure 4 - Three Types of Communications Services

Figure 5 is a simplified view of the protocol stack options for LunaNet user applications. The applications are expected to be network-based using either the Delay/Disruption Tolerant Networking (DTN) Bundle Protocol (BP) or Internet Protocol (IP). However, a user application may use link layer services (dashed line) using the Consultative Committee on Space Data Standards (CCSDS) Advanced Orbiting Systems (AOS) standard. The direct use of link layer services is intended for message services for LunaNet applications only and should be deprecated for user applications. Connections to a LunaNet access point over any available link will allow the user’s data to route to its destination. Though LunaNet will provide link layer services, network-based applications will allow for the evolution and scalability of both user and provider systems.

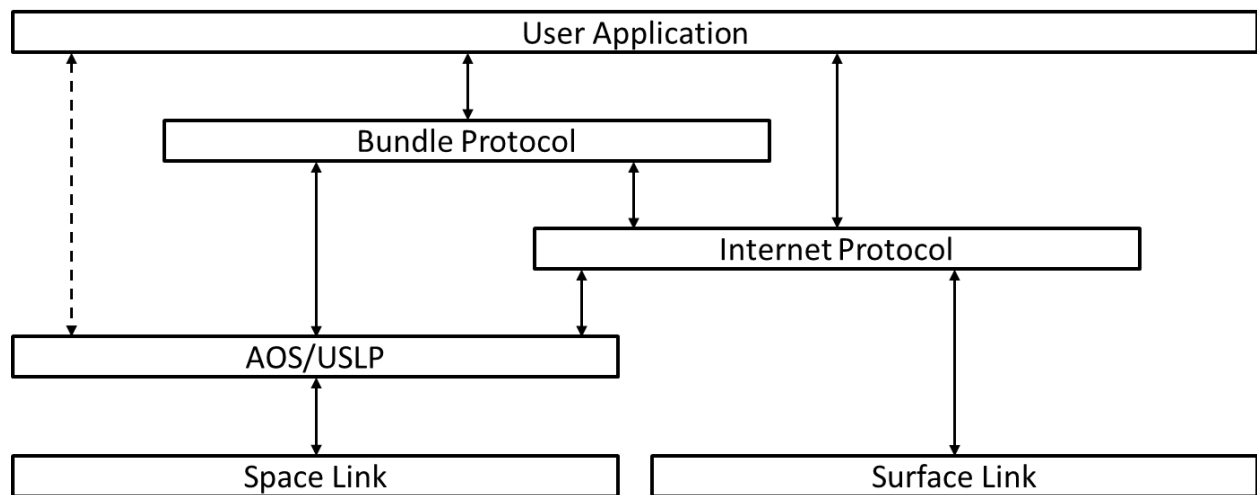

Figure 5 – User Application Simplified Protocol Stack

3.1.1 Real-Time Communications Services

Real-time communications services may be provided at both the link layer and the network layer.

3.1.1.1 Real-Time Link Layer Communications Services

Link layer services will allow the relaying of data at the frame level and requires no processing of user data within those frames. This may be required due to user link layer security or to enable higher speed operations. The link layer service may include the multiplexing, de-multiplexing, and forwarding of user data frames. For interoperability, the link layer services initially will require CCSDS AOS frames. Future

transition to available length frame standard is planned to simplify multiplexing and de-multiplexing data frames for users having different frame lengths, because AOS frames are fixed length. CCSDS Unified Space Data Link Protocol (USLP) is an expected link layer standard that will be included later. End-to-end delivery of data over a series of multiple links using link layer services will require pre-configuration of the full end-to-end path and is subject to interruption due to unplanned events.

3.1.1.2 Real-Time Network Layer Communications Services

Real-time network layer services provide end-to-end delivery of data over a series of multiple links with increased functionality and flexibility over the link layer services. The only network layer service guaranteed to provide end-to-end delivery to any network user is the DTN BP. However, operation assumptions for specific user applications will allow successful application support through real-time network layer services provided using the IP. Use of IP requires both source and destination to be operating within a portion of the network capable of supporting IP, such as the lunar surface. IP services are provided over AOS frames on the links described above or commercial standards, such as local wireless systems. Table 2 provides a summary of the IP service interfaces. Since DTN BP also provides the store-and-forward communications services, the interfaces for BP services are described by Table 3 in the following section.

Table 2 - IP Service Interfaces

Interface Name	Description	Applicable Interfaces	Applicable Documents
IP over CCSDS Encap/AOS	IP packets encapsulated using CCSDS encapsulation service and inserted into AOS frames	All AOS link layer service interfaces	CCSDS 702.1-B-1
IETF Standards	IP packets over current terrestrial standards	All terrestrial standard based interfaces	

3.1.2 Store-and-Forward Communications Services

Interoperable store-and-forward communications services will be provided using DTN BP. In situations where DTN nodes are connected via an IP network, lunar surface networks, terrestrial networks, and/or on-board networks, the DTN bundles can be carried via Transmission Control Protocol (TCP) or User Datagram Protocol (UDP) convergence layer protocols over standard terrestrial internet protocols (see Section 3.1.1.2). For those cases where no direct IP connection is available or not suitable due to the link characteristics, the DTN bundles are carried by either a Licklider Transmission Protocol (LTP) convergence layer with LTP segments encapsulated in encapsulation packets or directly in encapsulation packets, which will be carried over an AOS or USLP link layer (see Section 3.1.1.1). Table 3 provides a summary of these options.

Table 3 - Bundle Protocol Service Interfaces

Interface Name	Description	Applicable Documents
Bundles / TCPCL	Bundles are forwarded via TCP convergence layer adapter over TCP/IP	LNIS4-TBD-3001
Bundles / UDPCL	Bundles are forwarded via UDP convergence layer adapter over UDP/IP	LNIS4-TBD-3002
Bundles / LTPCL	Bundles are forwarded via LTP convergence layer adapter over Encapsulation Packet Protocol	CCSDS 734.1-B-1 CCSDS 133.1-B-3

Bundles / EPPCL	Bundles are forwarded via EPP convergence layer adapter over Encapsulation Packet Protocol	CCSDS 133.1-B-3
-----------------	--------------------------------------------------------------------------------------------	-----------------

3.1.3 Messaging Services

Messaging services will provide a standard way for messages to be transferred directly over a link layer service or a network layer service. These messaging services will be utilized by LunaNet applications or protocols. LunaNet applications are applications for service acquisition, PNT, alerts, and other LunaNet services. These standard messages are to be employed across user links, provider crosslinks, as well as direct-to-Earth (DTE) links. Methods for carrying these messages over the other communications service are also standardized.

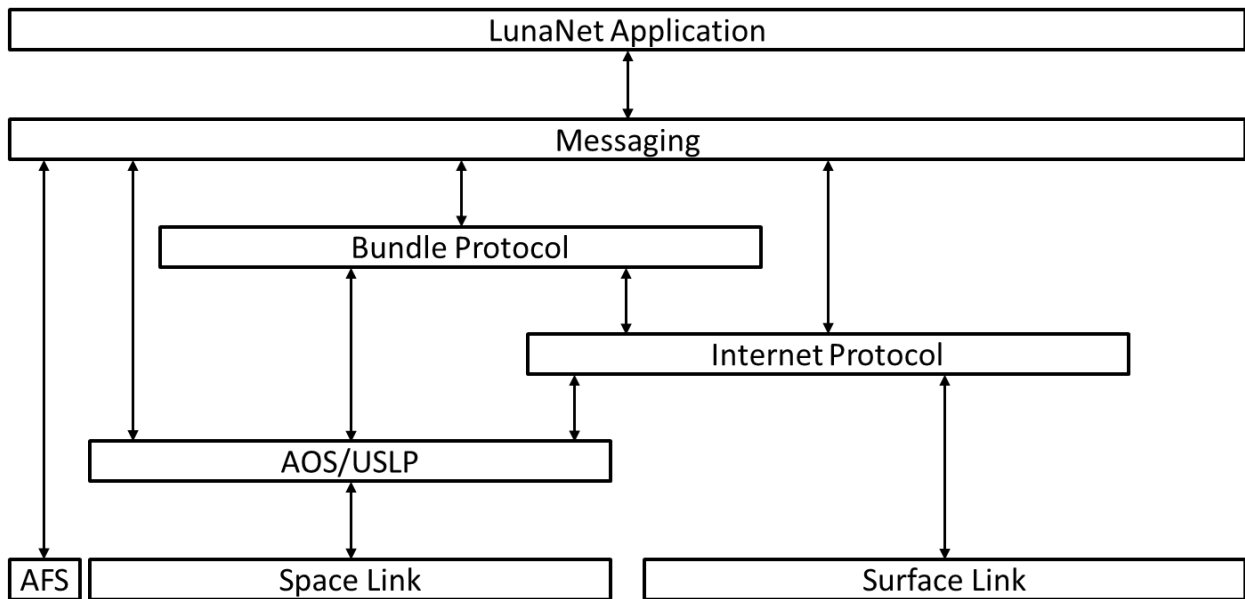

Figure 6 - LunaNet Applications Simplified Protocol Stack

Table 4 - Messaging Services Interfaces

Interface Name	Description	Applicable Documents
Message over Link	Messages inserted directly into AOS frames for transfer over a single link.	LNIS4-TBD-3003
Message over IP	Messages inserted into IP packets to allow for multiple IP hops to IP destination.	LNIS4-TBD-3004
Message over DTN	Messages inserted into DTN bundles to allow for multiple hops to any LunaNet destination.	LNIS4-TBD-3005
Message over AFS	Messages transmitted over the Augmented Forward Signal (AFS) may be carried in a unique manner to accommodate the low AFS data rate.	LNIS4-TBD-3006

Standardized protocols for navigation (PNT) services, network acquisition, space weather alerts, search and rescue, etc. will define the specific messages for those functions. The messaging services are not intended for user data flows from applications other than LunaNet applications. A generic use of the messaging

service is shown below in Figure 7. Messages are being exchanged between a LunaNet node and a user as part of the execution of a LunaNet application or protocol. The messages being exchanged are formatted within a standardized messaging format and carried over the interfaces as indicated in Table 4.

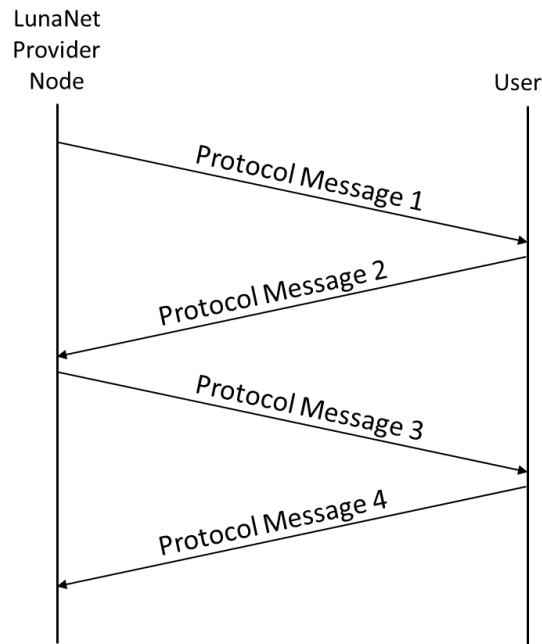

Figure 7 - LunaNet Node and user exchange messages using messaging services

The messaging services will provide methods for identifying message priorities. A publish and subscribe capability may be used for this service, except for specific messages needed for PNT observables via the PNT reference signals described in Section 3.2.1. The AFS link, described later in this document, will carry messages differently than the other space links due to the lower available data rate.

The specific standards for the messaging services are still being determined. Until the messaging services are in place, the LunaNet application messages will be transported along with the user application as depicted in Figure 5. In this case, the messages may be included in CCSDS encapsulation packets directly inserted into an AOS virtual channel. This is depicted by the dashed line in Figure 5. For ease in interpreting the remainder of this document, the message IDs and titles are provided in Table 5. Appendix D provides information on the LunaNet application messages expected to be carried on the AFS link.

Table 5 - Message ID and Titles

Message ID	Message Title
MSG-G1	LunaNet Network Access Information
MSG-G2	Health and Safety
MSG-G3	MAntennaProperties
MSG-G4	SOrbit Ephemeris+Clock correction
MSG-G5	MOrbit Almanac
MSG-G6	SOrbit Almanac
MSG-G7	SOrbitState /Location

MSG-G8	Time and Frequency Synchronization (fine)
MSG-G9	Time and Frequency Synchronization (frame)
MSG-G10	Maneuver
MSG-G11	SAttitude State/Ephemeris
MSG-G12	MAttitudeEphem
MSG-G13	Observations
MSG-G14	Conjunction
MSG-G15	Maplet
MSG-G16	Map Comprehensive
MSG-G17	Ancillary info
MSG-S18	Search and Rescue Alert
MSG-S19	Acknowledge- of SAR - LvL1
MSG-S20	Acknowledge- of SAR - LvL2
MSG-G21	User Message Request
MSG-G22	Acknowledge- of non-SAR MSG
MSG-G23	GNSS Augmentation
MSG-G24	Detection Alert
MSG-G25	Science
MSG-G26	UIS Request
MSG-G27	UIS Response
MSG-G28	User Schedule Notice
MSG-G29	FF Commands

3.2 Position, Navigation, and Timing Services

PNT services enable missions to determine position, velocity, surface location, plan trajectories, execute maneuvers, and maintain accurate time in a timeliness sufficient to meet mission requirements. PNT services can be offered via a combination of standardized signals for Doppler, ranging, timing, and standard messages and protocols for the exchange of measurements and products. These are needed for safety, situational awareness, communication, and mission and science objectives.

To offer these services and provide interoperability, the intent is to take maximum advantage of the communications links through judicious signal structure definitions. This can be accomplished in several ways. One method is to provide PNT through dedicated communications links with a user. However, there is a need for lunar-global provisioning of PNT services to provide adequate geometry and appropriate time-to-first fix to meet user requirements. Thus, a second method using an AFS provides PNT functionality independent of dedicated user communications links to enable multiple user reception of the signal simultaneously. Through the build-up of LunaNet nodes, this will establish a Lunar Augmented Navigation System (LANS) as described in section 3.2.2, leading to a Global Navigation Satellite System (GNSS)-like capability for lunar PNT services. Similar to GNSS, a Code Division Multiple Access (CDMA) signal structure will be used for the AFS communications link and can also be applied to dedicated proximity links.

For communications links other than CDMA, with a known transmit frequency, the receiver could measure the Doppler shift on the carrier. Non-CDMA links supported by pseudo-noise (PN) codes could provide an alternate method to derive pseudo-range measurements beyond the traditional two-way methods with ground source and measurement. In addition, a method whereby a specific data frame at an integer modulo 1-second based on an accurate and stable time reference source can be used to provide pseudo-range and time-transfer capability on these links.

For full interoperability, additional specifications will be developed as follows:

1. LunaNet and User Signal Structure Definition Document [AD1]
2. LunaNet Measurement Schema and Parameters Document [AD2]
3. LunaNet Detailed Message Definition Document [AD3]
4. LunaNet Location Services for Users Document [AD4]
5. Lunar Reference Frame Standard [AD5]
6. Lunar Time System Standard [AD6]

For effective interoperability in the PNT domain, these signal structures for LunaNet providers and for LunaNet users must be defined [AD1], along with the implementation schemas for measurements [AD2] and lunar reference systems [AD5], [AD6] for obtaining the measurements to ensure consistency in performance.

Appendix D identifies the PNT services and associated messages required for interoperability. The specific service identifications are explained in the subsections of 3.2. The specifics of the messages will be defined in standard protocols used as part of the provision of the services [AD3]. Interoperability also relies on defining the formats and contents; transmission periodicity, cadence, and latency; and prioritization for the messages for each signal type and service.

All PNT services described in sections 3.2.1 through 3.2.5 require the LunaNet provider to have knowledge of its own PVT state, as well as future predicted values. This information is required to be forwarded to users for the consumption of the related services, in the form of messages MSG-G4 and MSG-G5. Appendix D identifies additional messages that can be used to inform a comprehensive state of LunaNet provider node(s) or a LunaNet user.

The PNT services can be grouped into two categories, as shown in Figure 8:

- 1) **Dedicated Links:** This group of services include all the options described in the following sections that are not broadcast in 2483.5-2500 Megahertz (MHz). These services are expected to be provided by direct links between the user and the provider. Not all links will provide all the services described in sections 3.2.1 and 3.2.3 - 3.2.5. A dedicated link can provide a reference signal for PNT observables with the associated messages. Alternatively, a signal that is not inherently designed to offer PNT observables may still be employed to transmit messages that support PNT.
- 2) **Lunar Augmented Navigation System (LANS):** This service is provided from multiple provider nodes to multiple users at the same time, as described in section 3.2.2. The concept is similar to GNSS. This service is provided in 2483.5-2500MHz band via the AFS using the PFS5 signal. This service is expected to be provided with relatively large field-of-view LunaNet antennas to cover a large part of the service volume with the same signal. EOC service will be composed of a collection of LNSP nodes aimed at achieving global lunar coverage of a minimum of four simultaneous LANS nodes in view at any given time. Users employing omnidirectional or hemispherical antennas can therefore receive signals from multiple LunaNet nodes simultaneously.

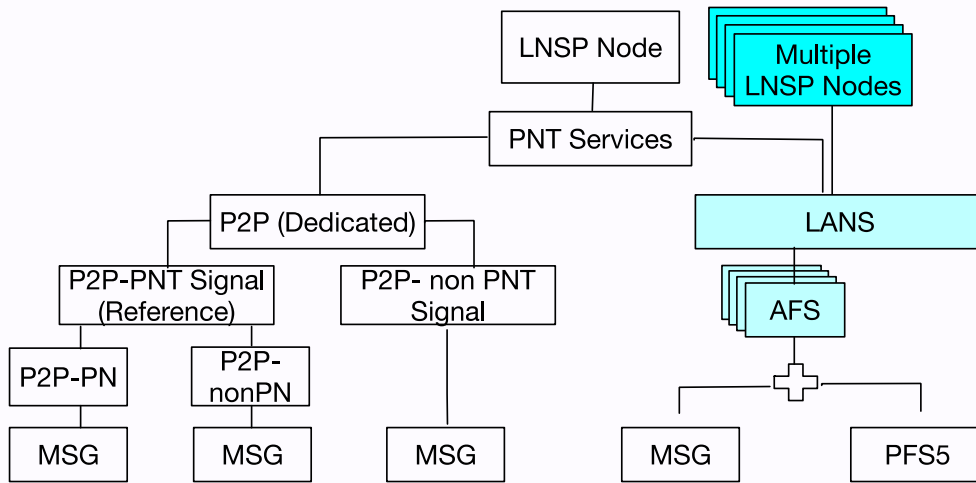

Figure 8 - PNT Services Provided by LunaNet

The following sections define and describe the services available from reference signals, including the special case of LANS. Then the concept of measurement services is introduced, followed by transponder, supplemental, and finally, location services. The figures in these sections use an arrow to indicate directionality associated with the notional image of a signal path.

3.2.1 Reference Signals

In the LunaNet concept, reference signals originate from a LunaNet node, as depicted in Figure 9. These reference signals offer users the opportunity to derive measurements which describe the relative dynamics of the link between the LNSP reference source and the recipient. Defining the properties of each reference signal source enables users to derive pseudo-range, timing, and one-way Doppler observables through their receiver system.

Note: While a signal similar to a LunaNet reference signal may be initiated by a user, for clarity this user-originating signal is not defined as a reference signal. Instead, the concept of a “one-way measurement service” is introduced in section 3.2.3. If a user transponds a LNSP reference signal, the LNSP node offers a “two-way measurement service” on that returned link as described in section 3.2.4.

A combination of one-way observables and related messages from different LunaNet sources are utilized by a user’s in-situ navigation system to estimate the user’s position (or surface location), velocity, and time. A user may elect to complement LunaNet observations with other measurement types, but those are not addressed in this document.

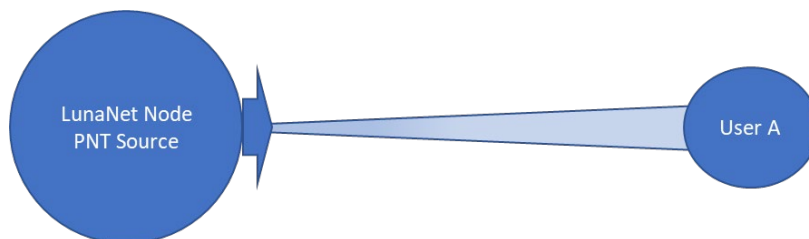

Figure 9 - Reference PNT Signals Provided by a LunaNet Node

3.2.1.1 One-Way Doppler Reference (1wDRef)

Most radio communications links may be employed for the purposes of obtaining one-way Doppler measurements by a user, provided the user has accurate knowledge of the center frequency employed by the source. This is best accomplished with the use of a fixed frequency transmission.

Differences in the measured frequency by the user will be due to Doppler, as well as frequency offsets from both the LunaNet and user's frequency oscillator sources. The LunaNet source conveys reference frequency value and deviations via a message, as identified in Appendix D.

3.2.1.2 Pseudo-Range and Timing Reference (1wRTRef)

The pseudo-range measurement approximates the distance between a LunaNet source and the user's receiver. The source emits a recognizable pattern at a given instant in time, which the user receives moments later, identifies, and timestamps. The delay measurement represents a one-way time of flight.

Depending on the characteristics of the communications link, these patterns will take the form of PN sequences or high-rate frame synchronization and identification (i.e., frame ranging). Frame ranging is the term used in this document to refer to "telecommand/telemetry ranging", with the telemetry ranging as defined in [RD24], and telecommand ranging definition proposed in [RD25]. While the latter is currently a work in progress, PN sequences have been employed in satellite ranging technologies for quite some time. PN codes as identified in CCSDS 414.1-B-2 and CCSDS 415.1-B-1 have traditionally been employed for two-way ranging purposes. To use them as an option for one-way measurements, a method (LNIS4-TBD-3007) must be set in place to convey information to the user correlating source PN phasing and the corresponding time of transmission. Signal structures like those utilized in GNSS, such as PFS5 links described later in this document, include PN sequences that repeat an integer number of times each second. This establishes a simple method for the LunaNet source to inform users of PN phasing and timing information to form a pseudo-range observation.

Pseudo-range measurements will include errors due to source and receiver time offsets, unaccounted equipment delays on both ends, and time dilation effects. Information concerning errors originating from the LunaNet source is provided to users via messages as identified in the tables in Appendix D.

3.2.1.3 Time-Transfer Reference (Tref)

A standardized method (LNIS4-TBD-3008) for a LunaNet node to provide a time reference will be implemented to allow users to have accurate time.

3.2.2 Lunar Augmented Navigation System (LANS)

The AFS is a special case instantiation of the reference signals described in section 3.2.1. The compatible LNSP nodes will transmit the AFS, as described in sections 3.5.2.1 and Appendix C, in the 2483.5-2500 MHz band (PFS5). A collection of LNSP nodes transmitting the AFS constitutes the LANS, which is illustrated in Figure 10.

LNSP nodes broadcasting AFS shall be synchronized among themselves and against a common reference time scale. Frequency offsets will be estimated against the reference by each provider. The user computes the time of arrival and frequency of the received CDMA signal by using the information provided in the broadcast navigation messages (e.g., ephemeris, clock corrections, and time and frequency information) to compute a pseudo-range, Doppler shift, and carrier phase. Considering the collection of observables from different LNSP nodes and the correlated broadcast navigation messages, the user can autonomously compute its position, velocity, and the difference between the local receiver clock and the LNSP system reference clock. Appendix D contains the mapping of messages to the LANS via the AFS.

As with all other PNT services, a common lunar-centric reference frame and time system is defined per section 3.2.6. Each LNSP shall ensure they either implement these reference systems directly (e.g., signals are synchronized with the lunar reference time and the lunar reference frame is used in the navigation products) or provide sufficient information to the user in the broadcast navigation messages to refer to these common reference systems (e.g., broadcast of the time offset of the specific LNSP time to the lunar reference time). Like GNSS, the LANS service will allow the user to compute code pseudo-ranges and carrier phase measurements from the AFS signal. Each LNSP shall ensure the AFS is provided with Signal-In-Space-Error (SISE) limited below the maximum values specified in Appendix C, which allows users to derive consistent and reliable navigation solutions based on AFS signals from multiple LNSPs.

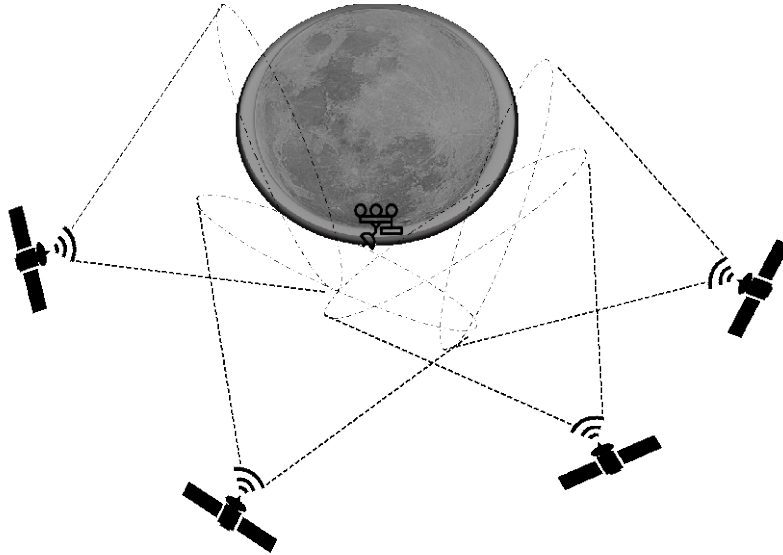

Figure 10 - LANS PNT Concept Provided by LunaNet Nodes

The LANS via AFS is a multiple access forward link and allows reception by multiple users from the same LNSP node (one-to-many). Additionally, it also supports a many-to-one concept (i.e., GNSS-like with AFS signals from multiple LNSP nodes received by one user) owing to the mandatory time synchronization of the nodes, the coordinated generation of PNT-specific navigation messages, and the CDMA differentiation among the LNSP nodes. Further details about the AFS and the PFS5 signal structure are provided in Appendix C.

The LANS service volume identifies the minimum space volume in which the LANS must be provided and performance must be met. For the IOC timeframe the service volume includes lunar surface areas below -75 degrees latitude and up to an altitude of 200 kilometers, supporting surface missions as well as users in low lunar orbit or in transit to/from the surface. The IOC service volume is depicted in Figure 11.

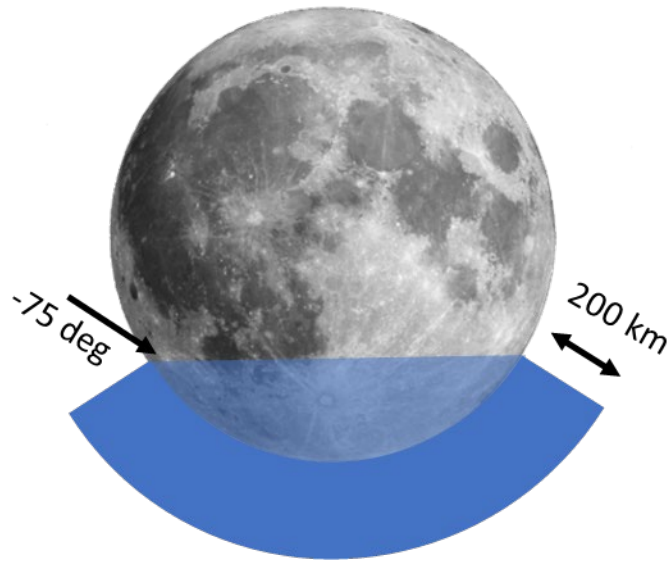

Figure 11 - LANS IOC Service Coverage and Performance Volume

The LANS service volume for the EOC timeframe includes lunar surface areas for all latitudes and altitudes up to a minimum of 200 kilometers for full global coverage of the moon. The EOC service volume is depicted in Figure 12.

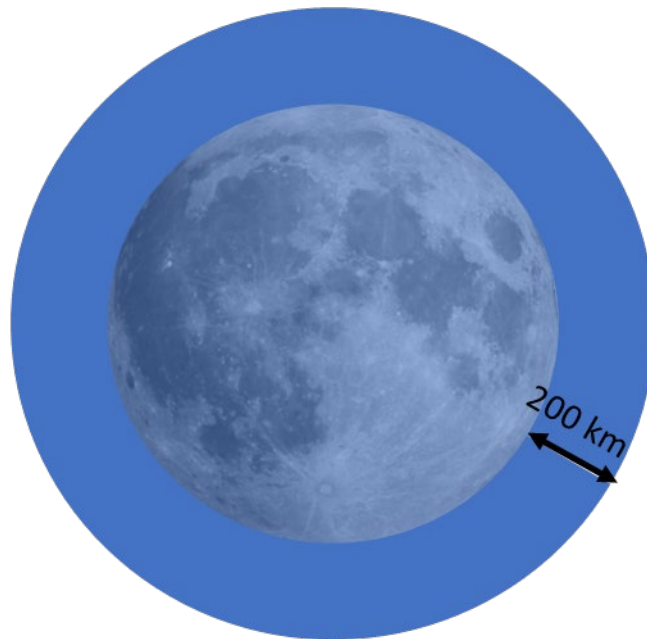

Figure 12 - LANS EOC Service Coverage and Performance Volume

3.2.3 One-Way Measurements

One-way measurements performed by LunaNet nodes are in reverse fashion to what is described in section 3.2.1 and explained herein and depicted in Figure 13. The users generate signals similar to the construct of a LunaNet transmitted reference signal, so that they enable LunaNet nodes to compute one-way Doppler and pseudo-range observables from the user. The resulting one-way measurement observables are forwarded to the necessary element via MSG-G13 messages, as identified in Appendix D.

Note: A navigation system may elect to complement LunaNet observations with other measurement types, but those are not addressed in this document. Note: A navigation system may elect to complement LunaNet observations with other measurement types, but those are not addressed in this document. Note: A navigation system may elect to complement LunaNet observations with other measurement types, but those are not addressed in this document.

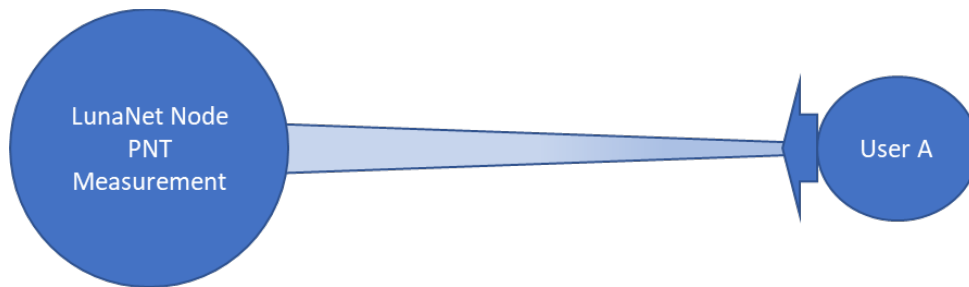

Figure 13 - One-Way Measurements Performed by a LunaNet Node

3.2.3.1 One-Way Doppler Measurement (1wDMeas)

One-way Doppler measurements may be carried out for most incoming radio communications signals by tracking the frequency of the received signal and reporting the delta with respect to a defined source frequency. These measurements become valuable when the original frequency transmitted by the user is known. The quality of the measurement will depend on the stability of the user's frequency source, as well as the signal-to-noise ratios of the received signal. Errors due to frequency offsets between user and LunaNet frequency references may be estimated by the corresponding navigation system. Users employ messages, as identified in Appendix D, to convey their transmitted frequency values and deviations.

3.2.3.2 Pseudo-Range Measurement (1wRTMeas)

The pseudo-range measurement is as described in section 3.2.1.2, though for a measurement concept the user generates the constructed signal that is utilized by the measuring LunaNet system to obtain a pseudo-range observable. The LunaNet system must be compatible with, and knowledgeable of, the ranging signal characteristics employed by the user as indicated in the LunaNet and User Signal Structure Definition [AD1] interoperability specification.

Pseudo-range measurements will include errors due to source and receiver time reference offsets, and unaccounted phase delays and time corrections beyond what can be determined. The LunaNet measurement system interprets information concerning these errors originating on the user end via user-provided messages, as indicated in Appendix D, MSG-G4. LunaNet measurement systems are to be included in the corresponding observation messages, as indicated in Appendix D, MSG-G13.

3.2.4 Two-Way Measurements

Two-way measurements performed by LunaNet are similar to two-way radiometric services historically provided by the different tracking networks, where the tracking stations compare the transmitted and received signals to derive observations of round-trip Doppler and range in terms of time-of-flight delay. In the LunaNet scenario, the LNSP node originates the transmit signal. These measurements require users to return a signal that is coherently related to the signal they received from the LNSP node, as illustrated in

Figure 14 below. Range measurements can be supported by non-coherent, two-way communication interfaces by means of frame ranging as described in section 3.2.4.2.

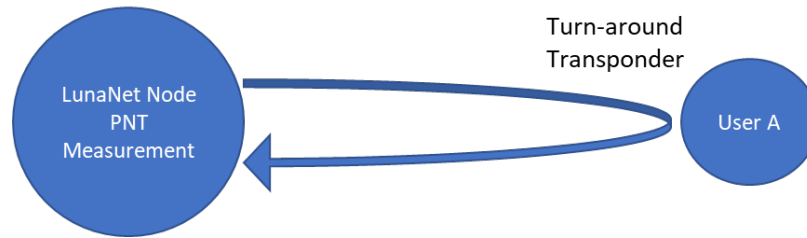

Figure 14 - Two-Way Measurements Performed by LunaNet Node

Two-way measurement observations are disseminated to the required element via MSG-G13 messages, as indicated in Appendix D.

3.2.4.1 Two-Way Doppler Measurement (2wDMeas)

Two-way Doppler measurements require LunaNet to determine the differences in phase between transmitted and received signal center frequencies at predetermined time intervals. The user must coherently transpond the received frequency from LunaNet by implementing a predefined turn-around ratio.

3.2.4.2 Range Measurement (2wRMeas)

The range measurements performed by LunaNet can be separated into three categories: non-regenerative, regenerative, and frame ranging. Non-regenerative ranging (transparent ranging) involves the user filtering and re-modulating the ranging signal onto the return signal. This method does not require the user to have prior knowledge of the ranging signal utilized for the service, only the frequency bandwidth allocated to it. The PN ranging signals described in CCSDS 414.1-B-2 may be used for this purpose. Regenerative ranging involves PN code acquisition by the user and the return of a synchronized return PN ranging signal. It reduces the amount of noise present in the measurement, resulting in higher accuracies. The PN ranging signals described in CCSDS 415.1-B-1 and CCSDS 414.1-B-2 may be used for this purpose. Frame ranging involves timestamping and identification of synchronized information frames. It is particularly useful in high-rate communications links, where elevated data frame rates facilitate more accurate time resolution. A frame ranging standard is TBD (LNIS4-TBD-3009)

3.2.5 Two-Way Transponder

Two-way transponder services support a similar process as described in Section 3.2.4, however, with the LunaNet and user roles reversed. In the transponder scenario, the user generates the source signal, and a LNSP node transponds that signal and returns it to the user, as depicted in Figure 15. Users must then be capable of performing the two-way Doppler and range measurements on the signal LunaNet sends back to them.

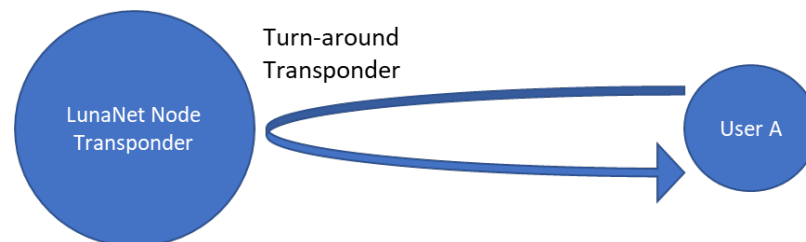

Figure 15 – Two-Way LunaNet Node Transponder

3.2.5.1 Two-Way Coherent Doppler Transponder (2Wd-XPND)

In support of user two-way Doppler measurements, the LunaNet element coherently relates its transmitted frequency to the frequency received from the user. The turn-around ratios applied by LunaNet are the inverse of the ratios employed by user transponders to maintain the frequency allocations assigned.

3.2.5.2 Non-Regenerative Range Transponder (2Wnrr-XPND)

In addition to what is performed for the two-way Doppler transponder service, a non-regenerative LunaNet transponder filters and re-modulates the ranging signal onto the forward signal. The LunaNet provider does not require knowledge of the ranging signal type employed by the user. The bandwidth allocated to the ranging signal and used by the LunaNet provider for filtering shall be TBD (LNIS4-TBD-3010).

3.2.5.3 Regenerative Range Transponder (2Wrr-XPND)

The regenerative ranging transponder service involves PN code acquisition by the LunaNet provider, followed by the transmission of a synchronized PN ranging signal transmitted to the user. The PN ranging signals described in CCSDS 415.1-B-1 and CCSDS 414.1-B-2 may be used for this purpose.

3.2.6 Supplemental Navigation Products (Nav-Supp)

Additional navigation products are embedded in standardized messages to allow for exchange between network elements of in-situ navigation-enabling and PNT-related information, as identified by message descriptions in Appendix D. This section provides an overview of the supplemental navigation products.

3.2.6.1 Lunar Reference Frame

The use of a common lunar-centered, selenocentric reference frame across LunaNet PNT services enables seamless consumption of the services, irrespective of specific LNSP or users. The lunar reference frame is described in detail in Lunar Reference Frame Standard (LNIS4-TBD-AD0005) [AD5]. Each LNSP shall either provide self PVT and ephemeris information in the common specified lunar reference frame or provide a means for the necessary coordinate transformations with respect to the specified lunar frame reference frame.

3.2.6.2 Lunar Reference Time

The use of a common lunar reference time across LunaNet elements is required to enable synchronization of services and time in the lunar domain. This common lunar reference time is described in detail in Lunar Time System Standard (LNIS4-TBD-AD0006) [AD6]. Each LNSP shall provide PNT services either directly synchronized with the standard Lunar Time or provide a means for the necessary time corrections to achieve standard Lunar Time.

3.2.6.3 Lunar Potential Model

To ensure alignment for navigation services and products, a consistent set of coefficients that represent the lunar gravity model in degree and order will be defined in Lunar Reference Frame Standard [AD5] and the coefficients can be distributed by LNSP provider nodes.

3.2.6.4 Lunar Orientation Parameters

Similar to Earth Orientation Parameters, the oscillations of the lunar principal axis undergo precession and nutation that can be described in parametric form, defined in Lunar Reference Frame Standard [AD5] and distributed by LNSP provider nodes.

3.2.6.5 Constellation Orbital Parameters

To plan and acquire services from provider constellations, users need almanacs that provide coarse orbital information for each of the provider nodes. This covers the full LunaNet constellation across all providers. In addition, there is a provision for LunaNet to distribute ephemeris information for Earth-centric GNSS constellations in support of receivers using weak signals from the Earth-centric GNSS.

3.2.6.6 Map Dissemination

To serve the navigation needs of users, LunaNet can distribute messages that contain information on lunar maps. This covers sectorized maplets, version numbers, and complete high-resolution digital elevation maps (DEMs).

3.2.6.6 Conjunction Data

To aid space situational awareness and avoid collisions between resident space objects, LunaNet will disseminate conjunction data in MSG-G14.

3.2.6.7 Asset Specific Parameters

Information specific to either a provider node or a user may be needed to improve navigation knowledge and insight. This includes maneuver information, state estimation covariance, estimator state transition matrix, and attitude/orientation.

3.2.7 Location Service (Loctn)

A LunaNet provider can implement location services as part of their service portfolio. This service provides a computation of the user PVT based on observations received by the LNSP nodes and disseminates the product via MSG-G7. The LunaNet provider capable of carrying out location services receives observations from multiple sources via MSG-G13. Other messages may be needed as a supplement if measurements were obtained by other LunaNet assets, such as MSG-G4 and MSG-G1. These observations are routed to the navigation system responsible for deriving the user's position and velocity, and potentially time. A request for location services includes necessary information for performing location or orbit determination for a specific user. Additional information on the location service will be defined in [AD4].

3.3 Detection and Information Services

Detection and information services include LunaNet applications within the network infrastructure to support alerts and critical information for user operations. Examples include space weather alerts triggered by instrumentation within provider systems and Lunar Search and Rescue (LunaSAR) beacon detection/location. These applications would generate and transmit messages using the formats and interfaces described in Appendix C. These services would have standard messages specific to their functions, such that all users receiving the messages will be able to understand them. The messages would be communicated using the messaging services described in 3.1.3.

Table 6 - Detection and Information Services

Service	Description	Required Interop Standards
LunaSAR	Determines user location and gathers critical user status	LunaSAR Message Content / Format Distress Message Prioritization Possible signal design

Space Weather	Alerts and other relevant information concerning Space Weather	Space Weather Messages
---------------	----------------------------------------------------------------	------------------------

3.3.1 Lunar Search and Rescue (LunaSAR) Services

LunaSAR services enable users to report location and distress information via internationally recognized messaging standards modelled after current state-of-the-art messaging content used in terrestrial search and rescue (SAR) activities.

LunaSAR services require a combination of reception, prioritization, and re-broadcast/pass-through of distress messages on LunaNet DTE and proximity links. LunaSAR message content is defined via inputs from the extravehicular activity (EVA) user community and SAR best practices. LunaSAR services are envisioned as an EOC capability. LunaSAR messages leverage rotating field definitions to reduce message size, allowing for robust low-data rate message transmissions from disadvantaged users to the LunaNet constellation at low power requirements and constrained link-budgets. LunaSAR services include location reporting of distress information, and low-data-rate bi-directional messaging between LunaSAR beacon users and message recipients such as Earth-based mission controllers, lunar surface assets, and lunar encampments.

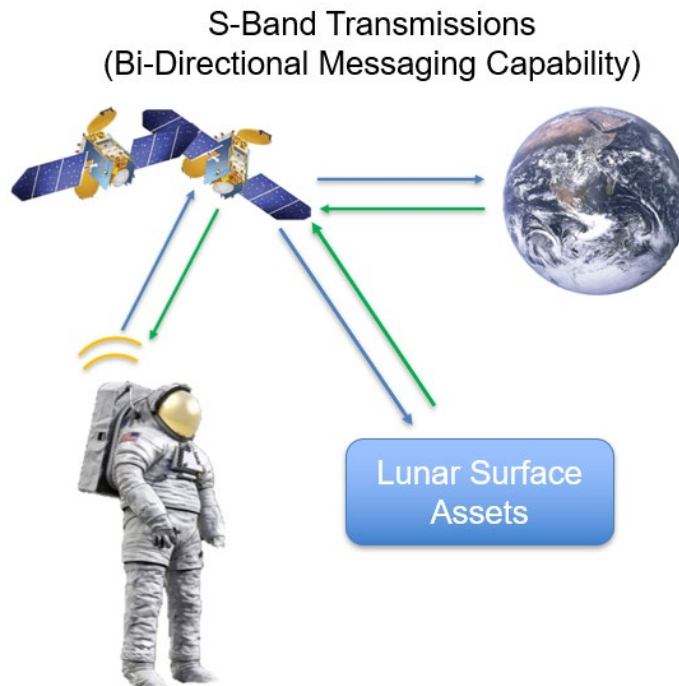

Figure 16 - LunaSAR Data Path ConOps

Four main steps describe the LunaSAR concept of operations and associated links:

- 1) Distress signal broadcast (beacon to LNSP link): The low power SAR beacon will transmit a distress signal that needs to be received by one or more LNSP nodes. The distress message might include the position of the beacon (if determined through the LunaNet PNT services) or the beacon position might be computed by the LNSP (or another actor) via triangulation of the beacon as received by multiple LunaNet nodes. A beacon might not know where the LNSP satellites are and might not have directive antenna capabilities, so the distress message might be broadcast and arrive at the LNSP with low power, this might require a dedicated, protected band, TBD.

- 2) Distress signal processing and start of rescue operation (LNSP node to Earth (DTE)): The distress message is sent to Earth for processing and activation of the rescue operation. A return message to the distress source is generated. Note: in the future, the SAR control center might be located on the Moon's surface.
- 3) LunaSAR return message (LNSP node to beacon link): The return message to the beacon is broadcast by the LNSP node. This message serves to inform the beacon that the distress message has been received and the rescue operation is ongoing. Considering the potential limitations of the user in terms of communications capabilities, the return message will be broadcast as part of the AFS signals but can also be provided via direct point-to-point (P2P) links if available.
- 4) Rescue operation completion (links LNSP to/from beacon): During the rescue operation, and until completion, there might be multiple activities and links being utilized (dedicated P2P communications links if available).

LunaSAR's distress alert service is potentially received on PRS5 [LNIS4-TBR-3001] and responded to over the PFS5 [LNIS4-TBR-3001] links and are prioritized for rebroadcasting when received by the LunaNet orbiting asset(s). Prioritization aligns with the principles of terrestrial distress tracking services commercially available to those engaged in dangerous activities.

LunaSAR messages are notionally formatted in Concise Binary Object Representation (CBOR) formatting to allow for increased processing and transfer speeds between LunaSAR users and LunaNet users. Note that rotating field messages described in this section are for example only and can be tailored to the specific lunar distress application/end-user hardware development. For example, message content would be derived from telemetry streams that could be monitored for faults (i.e., space suit pressure issue, radiation exposure, etc.) and trigger automated distress message generation. This process mimics current International Maritime Organization (IMO) and International Civil Aviation Organization (ICAO) provisions for automated distress tracking and notification services, to be replicated as applicable within the lunar domain in the EOC phase.

LunaSAR service broadcasts begin upon manual or automated triggering of distress transmissions and do not broadcast unless required. This aligns with the terrestrial standard for Cospas-Sarsat beacons and serves to preserve the nominal bandwidth within the relay system. Repetition rates following beacon/distress mode activation as well as signals and signal bandwidths used for the first step (distress beacon signal broadcast) are detailed in a separate document [AD7]. The PFS5 broadcast signals will include messages implementing the LunaSAR response to inform the distress beacon source that their request has been received and rescue actions are ongoing, this does not exclude sending the LunaSAR response also via other channels (e.g., P2P communication channels if available).

3.3.2 Space Weather Alerting Services

Space Weather alerts and related messages will be communicated using the messaging services, per Appendix D. The specific standard alert and message content are still TBD (LNIS4-TBD-3013). Initiation of weather alerts could be native to the LunaNet node in lunar orbit if suitable instrumentation is present, or it could be received from another asset (space or Earth) and relayed accordingly to users in lunar proximity.

3.4 Science Services

LunaNet assets may be able to support science objectives by using available radio/optical links and telemetry. Some science services may only require that LunaNet space equipment operate in a special mode

within the capabilities of the communications and navigation subsystem. These services may require standardized message formats to collect and share measurements from the variety of possible LunaNet systems.

3.5 Service Access

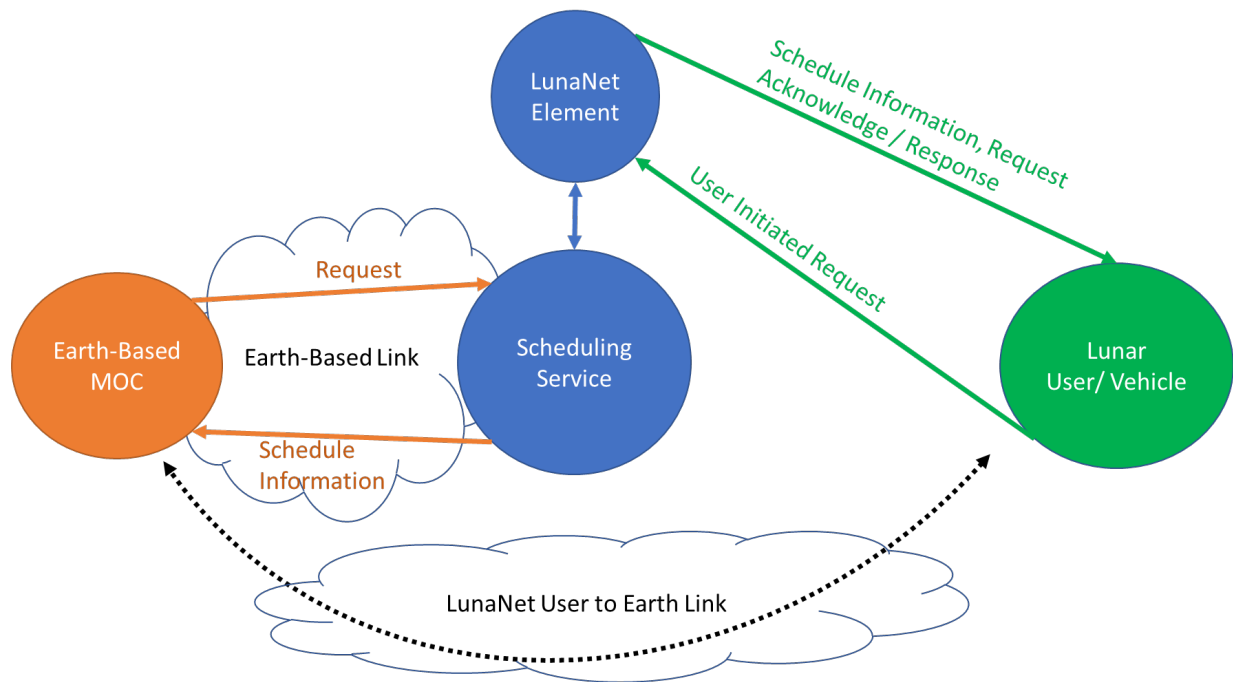

Figure 17 - LunaNet Scheduling Interfaces Overview

Users will be able to access services through a variety of methods (See Figure 17). Services may be scheduled through an LNSP’s scheduling service that allows a mission operations center to pre-schedule services with a network provider. Users that employ the services of more than one LNSP must schedule service separately with each LNSP and maintain their mission-specific combined schedule. Standardized methods for allowing one LNSP schedule services with another LNSP on behalf of a user are desired. Multiple access links will allow users to receive services immediately without any scheduling. User Initiated Services (UIS) will allow users to request and receive services over links between the user and a LunaNet provider node.

3.5.1 Earth-based Scheduling Service

Each LunaNet service provider may have their own unique interface for Earth-based schedule requests. No standards for this interface have been identified yet. The CCSDS 902.1-B-1 Simple Schedule Format Specification is a starting point for the identification of the full standards required.

3.5.2 Multiple Access Links

3.5.2.1 Multiple Access Forward Link/Augmented Forward Signal (AFS) Service

A multiple access forward link will be implemented using the AFS design. The signal represented as PFS5 in the LNSP-User Proximity Interfaces, and further described in Appendix C, will provide navigation and ancillary communications services simultaneously to multiple users in the lunar region without the need for

a user to establish dedicated proximity links with a particular LunaNet element. A single frequency will be used for the AFS signal and systems will be optimized to maximize coverage and availability for users. This optimization will likely lead to a lower available data rate, so the AFS data will be restricted to certain LunaNet application messages, as defined in Appendix D.

In addition, the AFS serves as an entry point to the LunaNet network. Users entering the service volume acquire the AFS signal and obtain a coarse state of services available. This service enables LunaNet to provide users with important information and data, such as contact information, schedule, service availability, position of different LunaNet elements, and acknowledgement of user requests or receipt of messages. Given the ubiquitous nature of the service, it serves as a dissemination channel for relevant notifications and alerts via provision of standard messages (3.3.2) and LunaSAR response messages (3.3.1).

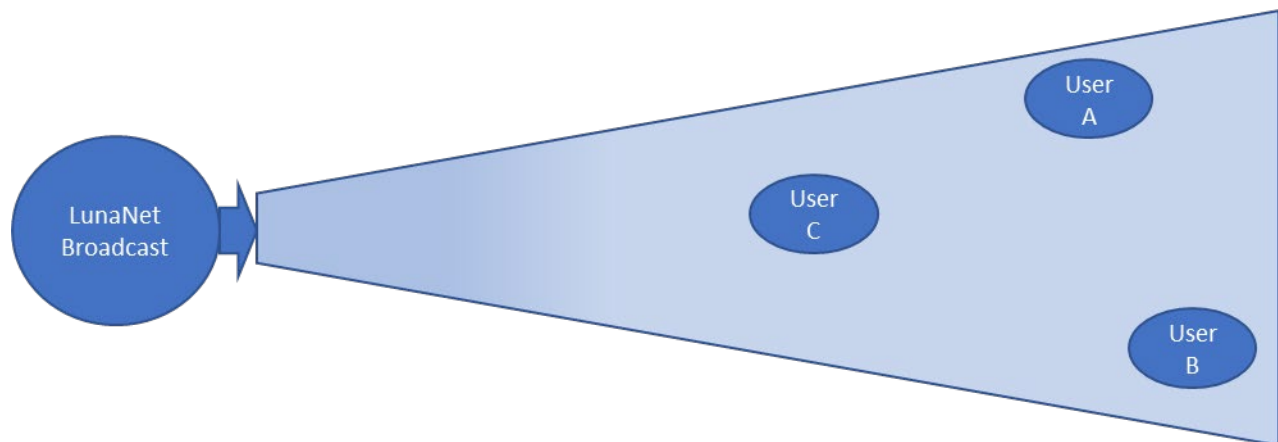

Figure 18 - Augmented Forward Signal Service Provided by a Single LunaNet Source

Refer to Appendix C for AFS signal structure definition and message requirements.

3.5.2.2 Multiple Access Return Link

The multiple access return link provides users with a highly available interface to initiate service requests, forward situational awareness messages, or send search and rescue alerts to the LunaNet network. This may also be used for lower rate user telemetry and science data. Refer to Appendix D for supporting message definitions. The PRS5 CDMA signal design will support simultaneous links from multiple users and PNT functions described in 3.2.3.

3.5.2.3 User Initiated Services

User Initiated Services (UIS) may be implemented through service acquisition protocols incorporating messages using the messaging services or through a hailing approach. Standards for both approaches are TBD (LNIS4-TBD-3014). User Initiated Services (UIS) give lunar user assets the capability to autonomously access the lunar communications infrastructure to report periodic telemetries, inform on anomalies and request services or network resources to the service provider (e.g., schedule a comms session). Additionally, it also allows mission owners/service providers to page and track user assets and task them at any time.

UIS may be implemented through service acquisition protocols incorporating messages using the messaging services (See section 3.1.3) over any available communications path or through a hailing approach. An adaptation of the UHF Proximity-1 hailing process might be used as a physical mechanism for UIS.

The use of a UIS protocol over messaging channels or through hailing methods would be used for any services in any frequency band. For example, Ka-Band UIS might be possible using the S-Band hailing method (i.e., dual band terminals) or a dedicated Ka-Band hailing mechanism. Broadcast channels such as LANS could support UIS as well.

4. LUNANET SERVICE PROVIDER TO USER INTERFACES

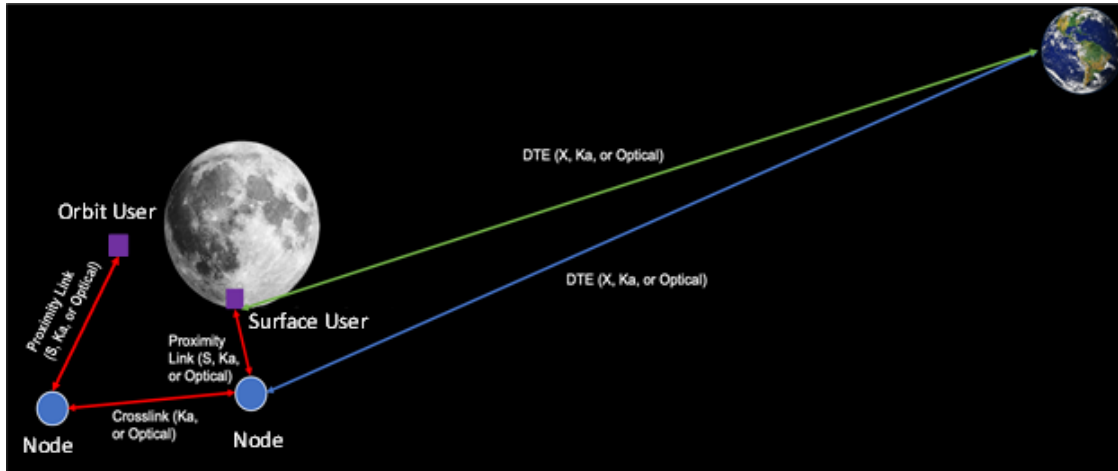

Figure 19 - Functional Interfaces and Corresponding Frequency Bands

The functional interfaces and corresponding frequency bands for the lunar radio frequency links are shown in the following sections. Allowable signal bandwidths and power levels will be determined through the spectrum management process. Standards for optical link interfaces are TBD (LNIS4-TBD-4001). Communications link frequency ranges are specified in Figure 20 for IOC.

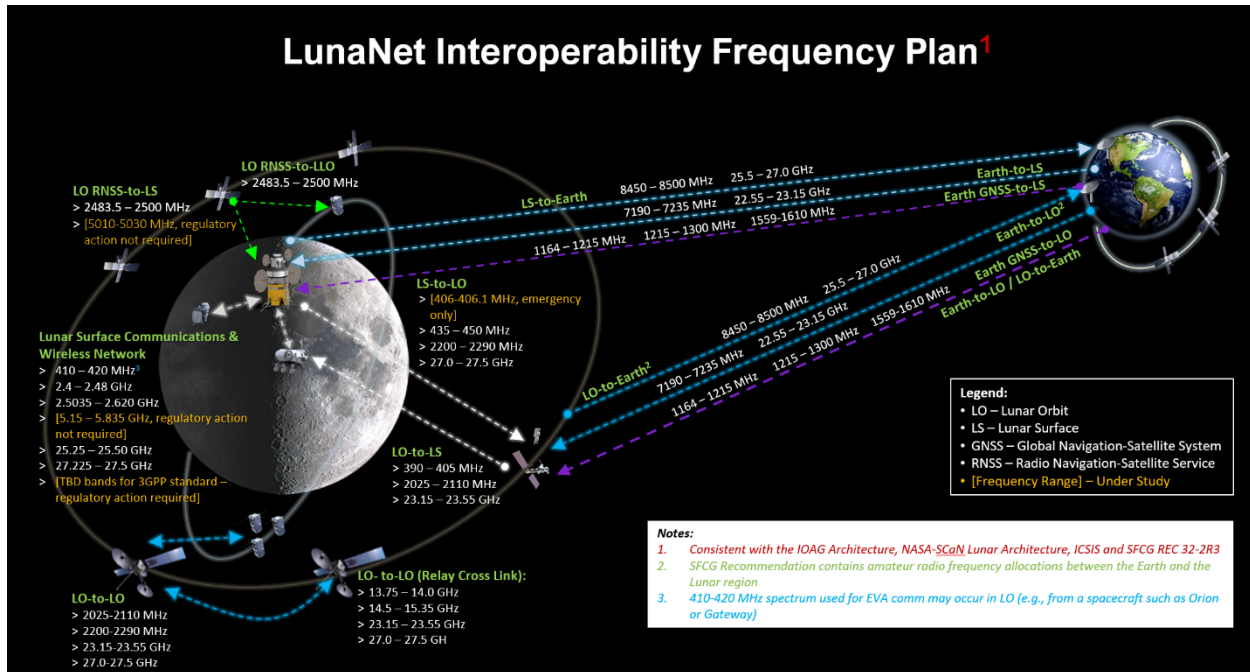

Figure 20- LunaNet Interoperability Frequency Plan

Note: In Figure 20 “390-405 MHz and 435-450 MHz” are based on SFCG REC 32 2R3 frequencies and are to only be used outside the Shielded Zone of the Moon (SZM). 410 to 420 MHz is used exclusively for EVA communications.

4.1 LNSP-User Lunar Surface Interfaces

Table 7 summarizes the lunar surface-surface link layer service interfaces.

Table 7 - LNSP-User Lunar Surface-Surface Link Layer Service Interfaces

Interface name	Interface Type	Description	Targeted Frequency Range ¹	Applicable Documents
LS1	Short-range wireless network	Wi-Fi 6, Wi-Fi Certified AC	5.150-5.835 GHz (Lunar Near-side use only) (LNIS4-TBR-4001)	CCSDS 883.0-B-1 SFCG REC 32-2R3
LS2	Short-range wireless network	Wi-Fi 6, Wi-Fi Certified N	2.4-2.48 GHz	CCSDS 883.0-B-1 SFCG REC 32-2R3
LS3	Short-to-medium range wireless network with mobility and roaming	3GPP rel. 16 (and higher) (LTE and 5G LNIS4-TBD-4002)	LNIS4-TBD-4003	CCSDS 883.0-B-1

[1] The exact frequency channel(s) have not been determined and are subject to coordination.

[2] SFCG REC 32-2R3 identifies the need to provide sufficient out of band filtering to protect the 2483.5-2500MHz lunar orbit to lunar surface PNT band.

Note 1: Potential 3GPP bands should not overlap with SRS, SOS, ISS, RAS, RNSS, and RDSS bands, as defined by the SFCG.

Note 2: In wireless communications using 3GPP, uplink (UL), or reverse link, is defined as lunar surface user (astronaut/rover) to lunar surface base station (lander/tower). The downlink (DL), or forward link, is defined as lunar surface base station (lander/tower) to lunar surface user (astronaut/rover).

Note 3: 5.25-5.57GHz is allocated to SRS (active) on a primary basis; use of these frequencies for communications in the lunar region is on a non-interference and unprotected basis to SRS (active).

4.2 LNSP-User Proximity Interfaces

Table 8 provides a summary of the different signal formats across proximity links. Signals labeled PFS5 and PRS5 are designed to allow for the implementation of one-to-many interfaces, such as a forward link broadcast and a user to multiple provider return. Table 9 describes the codeword/message size for the signals defined in Table 8.

Table 8– LNSP–User Proximity Link Layer Service Interfaces

Interface	Frequency Range & Symbol Rate	Modulation & Coding	Ranging Supported [8]	Applicable Documents [4]	Explanation
Proximity Forward S-Band Data Only (PFS1a)	2025-2110 MHz $2 \text{ ksps} \leq R_s \leq 2 \text{ Msps}$	BPSK See Note [3]	No	CCSDS 131.0-B CCSDS 401.0-B	See Note [1]
Proximity Forward S-Band Medium Rate w/ Ranging (PFS1b)	2025-2110 MHz $48 \text{ ksps} \leq R_s \leq 1.024 \text{ Msps}$	PCM/PM/ bi-phase-L	Yes, PN Ranging Chip rate TBR (LNIS4- TBR-4002)	CCSDS 131.0-B CCSDS 401.0-B CCSDS 414.1-B See Note [5]	See Note [1] See CCSDS 401.0-B Section 2.2.7 for explanation of PCM/PM/bi-phase-L. TBR (LNIS4-TBR-4003): supplemental reference for implementation of PN ranging. Presence of residual carrier aids demodulation (e.g. large doppler dynamics scenarios).
Proximity Forward S-Band Low Rate w/ Ranging (PFS1c)	2025-2110 MHz $0.5 \text{ ksps} \leq R_s \leq 48 \text{ ksps}$ Sinewave Subcarrier Frequency $4 * R_s$ (or 8 kHz minimum)	PCM/PSK/PM +NRZ-L	Yes, PN Ranging on carrier	CCSDS 131.0-B CCSDS 401.0-B CCSDS 414.1-B See Note [5]	See Note [1] See CCSDS 401.0-B Section 2.2.4 for explanation of PCM/PSK/PM. TBR(LNIS4-TBR-4004): supplemental reference for implementation of PN ranging. Presence of residual carrier aids demodulation

Interface	Frequency Range & Symbol Rate	Modulation & Coding	Ranging Supported [8]	Applicable Documents [4]	Explanation
					(e.g., large doppler dynamics scenarios).
Proximity Forward S-Band High Rate Data Only (PFS1d)	2025-2110 MHz 1 Msps \leq Rs \leq 5 Msps	Filtered OQPSK/GMSK	No	CCSDS 131.0-B CCSDS 401.0-B See Note [5]	See Note [1] See CCSDS 401.0-B-Section 2.4.17A. To Be Recommended for S-band Lunar Proximity. Allows for higher data rates with bandwidth efficiency.
Proximity Forward S-Band High Rate w/ Ranging (PFS1e)	2025-2110 MHz 1 Msps \leq Rs \leq 5 Msps	GMSK +PN Ranging	Yes	CCSDS 401.0-B CCSDS 131.0-B See Note [5]	See Note [1] See CCSDS 401.0-B-Section 2.4.22A. To Be Recommended for S-band Lunar Proximity
Proximity Forward S-band Medium Rate w/ Ranging (PFS2)	2025-2110 MHz Fixed frequency assignments (LNIS4-TBD-4004) Symbol & Chip Rates (LNIS4-TBD-4005)	SS-BPSK CDMA (~3Mcps) or SS-UQPSK TBR (LNIS4-TBR-4005)	Yes	CCSDS 415.1-B CCSDS 131.0-B See Note [5]	See Note [2] Intent is medium data rate signal with spread spectrum PN ranging and user specific PN code. Differentiated from PFS5 in that PFS5 utilizes a relay specific PN code for navigation service. Allows for higher data rates than PFS5, and signal parameters could be modified to some extent for individual users.
Proximity Forward S-band Augmented Forward Service (PFS5)	2483.5-2500 MHz Fc = 2492.028 MHz	AFS Structure (Appendix C)	Yes	LunaNet and User Signal Structure Definition Document [AD1]	See Lunar Augmented Navigation System (LANS)
Proximity Return S-Band Data Only (PRS1a)	2200-2290 MHz 2 ksps \leq Rs \leq 2 Msps	BPSK See Note [3]	No	CCSDS 131.0-B CCSDS 401.0-B	See Note [1]

Interface	Frequency Range & Symbol Rate	Modulation & Coding	Ranging Supported [8]	Applicable Documents [4]	Explanation
Proximity Return S-Band Medium Rate w/ Ranging (PRS1b)	2200-2290 MHz 48 ksps \leq Rs \leq 1.024 Msps	PCM/PM/bi-phase-L	Yes, PN Ranging Chip rate TBR(LNIS4-TBR-4006)	CCSDS 131.0-B CCSDS 401.0-B CCSDS 414.1-B See Note [5]	See Note [1] See CCSDS 401.0-B Section 2.2.7 for explanation of PCM/PM/bi-phase-L. TBR(LNIS4-TBR-4007): supplemental reference for implementation of PN ranging. Presence of residual carrier aids demodulation (e.g., large doppler dynamics scenarios).
Proximity Return S-Band Low Rate w/ Ranging (PRS1c)	2200-2290 MHz 0.5 ksps \leq Rs \leq 48 ksps Sinewave Subcarrier Frequency 4*Rs (or 8 kHz minimum)	PCM/PSK/PM +NRZ-L	Yes, PN Ranging on carrier	CCSDS 131.0-B CCSDS 401.0-B CCSDS 414.1-B See Note [5]	See Note [1] See CCSDS 401.0-B Section 2.2.4 for explanation of PCM/PSK/PM. TBR: supplemental reference for implementation of PN ranging. Presence of residual carrier aids demodulation (e.g. large doppler dynamics scenarios).
Proximity Return S-Band High Rate Data Only (PRS1d)	2200-2290 MHz 1 Msps \leq Rs \leq 5 Msps	Filtered OQPSK/GMSK	No	CCSDS 131.0-B CCSDS 401.0-B See Note [5]	See Note [1] See CCSDS 401.0-B-Section 2.4.17A. To Be Recommended for S-band Lunar Proximity Allows for higher data rates with bandwidth efficiency.
Proximity Return S-Band High Rate w/ Ranging (PRS1e)	2200-2290 MHz 1 Msps \leq Rs \leq 5 Msps	GMSK+PN Ranging	Yes	CCSDS 401.0-B CCSDS 131.0-B See Note [5]	See Note [1] See CCSDS 401.0-B-Section 2.4.22A. To Be Recommended for S-band Lunar Proximity

Interface	Frequency Range & Symbol Rate	Modulation & Coding	Ranging Supported [8]	Applicable Documents [4]	Explanation
Proximity Return S-Band CDMA Return (PRS2)	2200-2290 MHz Fixed frequency assignments LNIS4-TBD-4006. Symbol & Chip Rates LNIS4-TBD-4007	SS-BPSK CDMA (~3Mcps) or SS-SQPN TBR(LNIS4-TBR-4008)	Yes	CCSDS 415.1-B See notes [7a, 7b] CCSDS 131.0-B See Note [5]	See Note [2] Intent is for a wide beam spread spectrum return intended for P2P links. Similar to PRS5 but allows for higher data rates (less spreading) and ranging. There is a possibility to support multiple users simultaneously, albeit much less than PRS5. Signal parameters could also be modified for user specific needs (LNIS4-TBR-4009).
Proximity Return S-Band CDMA Return (PRS5)	2200-2290 MHz Fixed frequency assignments (LNIS4-TBD-4008) Symbol & Chip Rates (LNIS4-TBD-4009)	SS-BPSK CDMA (~3Mcps) or SS-UQPSK (Appendix C) TBR(LNIS4-TBR-4010).	Yes	CCSDS 415.1-B See notes [7a, 7b] CCSDS 131.0-B	See Note [2] Low rate, many users multiple access return with ranging.
Proximity Forward Ka-band Data Only (PFKa1)	23.15-23.55 GHz 1 Msps \leq Rs \leq (LNIS4-TBD-4010)	BPSK or OQPSK	No	CCSDS 131.0-B CCSDS 401.0-B	
Proximity Forward Ka-band Variable Coding and Modulation (PFKa2)	23.15-23.55 GHz 1 Msps \leq Rs \leq (LNIS4-TBD-4010) Msps [6]	DVB-S2, SCCC, or LDPC-VCM	No	CCSDS 131.0-B CCSDS 401.0-B CCSDS 131.3-B CCSDS 431.1-R CCSDS 131.2-B	LDPC-VCM is not yet a formal CCSDS standard.
Proximity Forward Ka-band High-Rate Data Only (PFKa3)	23.15-23.55 GHz 1 Msps \leq Rs \leq (LNIS4-TBD-4011) Msps [6]	Filtered OQPSK/GMSK	No	CCSDS 131.0-B CCSDS 401.0-B	See CCSDS 401.0 -B- Section 2.4.21A.

Interface	Frequency Range & Symbol Rate	Modulation & Coding	Ranging Supported [8]	Applicable Documents [4]	Explanation
Proximity Forward Ka-band High-Rate Data w/ Ranging (PFKa4)	23.15-23.55 GHz 1.5 Msps ≤ Rs ≤ (LNIS4-TBD-4013) Msps [6], [8]	GMSK+PN	Yes	CCSDS 131.0-B CCSDS 401.0-B	See CCSDS 401.0-B-Section 2.4.22A. To be recommended for Ka-band Lunar Proximity.
Proximity Return Ka-band Data Only (PRKa1)	27.0-27.5 GHz 1 Msps ≤ Rs ≤ (LNIS4-TBD-4014) Msps [6]	BPSK or QPSK	No	CCSDS 131.0-B CCSDS 401.0-B	
Proximity Return Ka-band Variable Coding and Modulation (PRKa2)	27.0-27.5 GHz 1 Msps ≤ Rs ≤ (LNIS4-TBD-4015) Msps [6], [8]	DVB-S2, SCCC, or LDPC-VCM	No	CCSDS 131.0-B CCSDS 401.0-B CCSDS 131.3-B CCSDS 431.1-R CCSDS 131.2-B	LDPC-VCM is not yet a formal CCSDS standard.
Proximity Return Ka-band High-Rate Data Only (PRKa3)	27.0-27.5 GHz 1 Msps ≤ Rs ≤ (LNIS4-TBD-4016) Msps [6]	Filtered OQPSK/GMSK	No	CCSDS 131.0-B CCSDS 401.0-B	See CCSDS 401.0-B-Section 2.4.17A.
Proximity Return Ka-band Data w/ Ranging (PRKa4)	27.0-27.5 GHz 1.5 Msps ≤ Rs ≤ (LNIS4-TBD-4017) Msps [6]	GMSK+PN	Yes	CCSDS 131.0-B CCSDS 401.0-B	See CCSDS 401.0-B-Section 2.4.22A. To be recommended for Ka-band Lunar Proximity.

[1] The standard maximum bandwidth for non-spread spectrum S-band signals is limited to up to 5 MHz to allow systems to operate efficiently. S-band is intended for TT&C mostly.

[2] Standard maximum bandwidth for spread spectrum S-band signal is 6.16 MHz.

[3] NRZ-L shall be used for code symbols. NRZ-L is selected as the use of differential encoding (e.g., NRZ-M) would double decoding errors (one wrong level leads to two wrong transitions).

[4] The most recent version of the applicable standard shall be used, unless stated otherwise.

[5] Applicable document for some signals are to be determined. Standards development for lunar proximity communications is an ongoing effort.

[6] For high throughput Ka-band links, higher order modulations and coding schemes are recommended to maximize bandwidth efficiency. Bandwidth efficient modulation and coding schemes are being investigated for LunaNet implementation.

[7a] The option to use non-regenerative ranging in the 415.1-B book has been proposed and is being worked on at CCSDS.

[7b] The intent of unbalanced return in the 415.1-B book was for higher science return data rate on one channel. These concepts are superseded by CCSDS virtual channels, where data rates of telemetry and science are controlled by the frame rates of the channels. Single data channel balanced QPSK is recommended for the lunar proximity return links.

[8] This column indicates if the service supports ranging to allow radiometric tracking.

Additional observations applicable to Table 8:

a) An adaptation of Proximity-1 protocols (Ref CCSDS 211.0-B-6, CCSDS 211.1-B-4, CCSDS 211.2-B-3) for the use of lunar missions in S-Band is currently under consideration and will be evaluated based on spectrum and other technical considerations. Further details will be disseminated in future document releases.

b) In order to ease acquisition tracking, in presence of large Doppler dynamics, Doppler compensation could be used. As a specific example, for users with very low signal strength that require very narrow bandwidths, Doppler compensation might be required.

c) When using shaped pulses (e.g. filtered OQPSK, GMSK+PN) at the lower limits of the data rate range, BER degradation and/or synchronization issues can occur. At low data rates, the normalized loop bandwidth (loop bandwidth normalized to data rate) increases, which can result in BER degradation of the signal. Increasing the normalized loop bandwidth can allow for cycle slips in the tracking loop, which could result in link stability issues and can also degrade BER performance. The tracking loop bandwidth must be large enough to accommodate the link doppler rates, which is dependent on the specific geometry of each relay/user link. Developers and mission planners should ensure through hardware testing that the receiver can properly operate at the low data rates for the worst-case doppler scenarios that a specific user to relay (and relay to user) link will see.

Table 9 - Coding and Framing of Proximity Signals

				S Band							
				PFS/P RS 1a	PFS/P RS 1a	PFS/ PRS 1b	PFS/ PRS 1c	PFS/ PRS 1d	PFS /PRS 1e	PFS/P RS 2	PFS/ PRS 5
				BPSK	BPSK	PCM/ PM/bi- phase-L	PCM /PSK/ PM+ NRZ-L	Filtered OQPSK/ GMSK	GMSK +PN	(LNI S4- TBD- 4018)	SS- BPSK
Code	Rate	Codeword Size (Octets)	Message Size [4] (Octets)	0.002 - 1.0 Msps	1.0 - 2.0 Msps	0.048 - 1.024 Msps	0.0005 - 0.048 Msps	1.0 - 5.0 Msps	1.0 - 5.0 Msps	(LNI S4- TBD- 4019)	(LNIS 4- TBD- 4020)
LDPC [1], [2], [3]	1/2	256	128	X		X	X	X	X	X	
		1024	512					X	X		
		4096	2048		X						

	2/3	768	512			X		X	X		
		3072	2048								
	4/5	2560	2048		X			X	X		
	7/8	1020	892		X			X	X		
Conv.	1/2, k=7					X		X			
Uncoded			2048	X	X	X (LNIS4- TBR- 4011)		X (LNIS4- TBR- 4012)			
TBD											X

				Ka Band			
Code	Rate	Codeword Size (Octets)	Message Size [4] (Octets)	PFKa/ PRKa 1	PFKa/ PRKa 2	PFKa/ PRKa 3	PFKa/ PRKa 4
				BPSK/ OQPSK	VCM	Filtered OQPSK	GMSK+PN
				1.0 - X.X Msps	1.0 - X.X Msps	1.0 - X.X Msps	1.5 - X.X Msps
LDPC [1], [2], [3]	1/2	256	128				
		1024	512				
		4096	2048	X		X	X
	2/3	768	512				
		3072	2048	X		X	X
		4/5	2560	2048	X		X
7/8	1020	892	X		X	X	
Conv.	1/2, k=7						
Uncoded			2048	X		X	X
TBD					VCM		

Notes:

[1] See CCSDS 131.0-B- Section 7.4 for LDPC 1/2, 2/3, and 4/5.

[2] See CCSDS 131.0-B- Section 7.3 for LDPC 7/8.

[3] LDPC codes can be used with transfer frames up to the CCSDS limit (currently 65536 octets for USLP, 2048 octets for AOS) using slicing. See CCSDS 131.0-B- Chapter 8 and Chapter 11.

[4] All transfer frames shall be either AOS or USLP

4.3 LNSP-User DTE Interfaces

Table 10 provides a summary of the different signal definitions for the DTE links. DTE applies both to 1) direct links between Earth and lunar surface and 2) Earth to LunaNet relay node. In this document, the trunk link is considered a special type of DTE link. It is the link between a lunar relay orbiter and Earth station. The trunk links include both forward and return links. Table 11 describes the codeword/message size for the signals defined in Table 10.

Table 10 - LNSP-User Direct to Earth Link Layer Service Interfaces

Interface	Frequency Range & Symbol Rate	Modulation & Coding	Ranging Supported	Applicable Documents [2]	Explanation

X-band Uplink Medium Rate w/ Ranging (XU1)	7190-7235 MHz 64 ksps \leq Rs \leq 1.024 Msps	PCM/PM/bi-phase-L	Yes	CCSDS 131.0-B CCSDS 231.0-B CCSDS 401.0-B CCSDS 414.1-B	See CCSDS 401.0-B Section 2.2.7 for explanation of PCM/PM/bi-phase- L
X-band Uplink (XU2)	7190-7235 MHz 150 ksps \leq Rs \leq 1 Msps	GMSK+PN	Yes	CCSDS 131.0-B CCSDS 401.0-B CCSDS 414.1-B See Note [3]	See Note [1] See CCSDS 401.0-B- Section 2.4.22A
X-band Uplink Low Rate w/ Ranging (XU3)	7190-7235 MHz 0.5 ksps \leq Rs \leq 64 ksps	PCM/PSK/PM+NRZ-L	Yes	CCSDS 131.0-B CCSDS 231.0-B CCSDS 401.0-B CCSDS 414.1-B	See Note [1] See CCSDS 401.0-B Section 2.2.4 for explanation of PCM/PSK/PM.
X-band Uplink High Rate Data Only (XU4)	7190-7235 MHz 128 ksps \leq Rs \leq 10 Msps	Filtered OQPSK/GMSK	No	CCSDS 131.0-B CCSDS 401.0-B	See Note [1] See CCSDS 401.0-B- Section 2.4.17A.
X-band Downlink Medium Rate w/ Ranging (XD1)	8450-8500 MHz 64 ksps \leq Rs \leq 1.024 Msps	PCM/PM/bi-phase-L	Yes	CCSDS 131.0-B CCSDS 401.0-B CCSDS 414.1-B	See CCSDS 401.0-B Section 2.2.7 for explanation of PCM/PM/bi-phase- L
X-band Downlink (XD2)	8450-8500 MHz 150 ksps \leq Rs \leq 1 Msps	GMSK+PN	Yes	CCSDS 131.0-B CCSDS 401.0-B CCSDS 414.1-B See Note [3]	See Note [1] See CCSDS 401.0-B- Section 2.4.22A
X-band Downlink Low Rate w/ Ranging (XD3)	8450-8500 MHz 0.5 ksps \leq Rs \leq 64 ksps	PCM/PSK/PM+NRZ-L	Yes	CCSDS 131.0-B CCSDS 401.0-B CCSDS 414.1-B	See Note [1] See CCSDS 401.0-B Section 2.2.4 for explanation of PCM/PSK/PM.

X-band Downlink High Rate Data Only (XD4)	8450-8500 MHz 128 ksps \leq $R_s \leq$ 10 Msps	Filtered OQPSK/GMSK	No	CCSDS 131.0-B CCSDS 401.0-B	See Note [1] See CCSDS 401.0-B- Section 2.4.17A.
Ka-band Uplink High Rate Data Only (KaU1)	22.55-23.15 GHz 2 Msps \leq $R_s \leq$ 50 Msps [Upper Limit – (LNIS4-TBD-4021)]	Filtered OQPSK/GMSK Frame ranging [RD24, RD25]	No	CCSDS 131.0-B CCSDS 401.0-B	See Note [1] See CCSDS 401.0-B- Section 2.4.17A.
Ka-band Uplink High Data w/ Ranging (KaU2)	22.55-23.15 GHz 2 Msps \leq $R_s \leq$ 50 Msps [Upper Limit – (LNIS4-TBD-4022)]	GMSK+PN	Yes	CCSDS 131.0-B CCSDS 401.0-B CCSDS 414.1-B See Note [3]	See Note [1] See CCSDS 401.0-B- Section 2.4.22A
Ka-band Downlink High Rate Data Only (KaD1)	25.5-27.0 GHz 2 Msps \leq $R_s \leq$ 200 Msps [Upper Limit (LNIS4-TBD-4023)], See note [4]	Filtered OQPSK/GMSK Frame ranging [RD24, RD25]	No	CCSDS 131.0-B CCSDS 401.0-B	See Note [1] See CCSDS 401.0-B- Section 2.4.17A.
Ka-band Downlink High Data w/ Ranging (KaD2)	25.5-27.0 GHz 2 Msps \leq $R_s \leq$ 200 Msps [Upper Limit (LNIS4-TBD-4024)] See note [4]	GMSK+PN	Yes	CCSDS 131.0-B CCSDS 401.0-B CCSDS 414.1-B See Note [3]	See Note [1] See CCSDS 401.0-B- Section 2.4.22A

Notes:

[1] Standard maximum bandwidth for non-spread spectrum S-band signals is limited to up to 5 MHz to allow systems to operate efficiently. S-band is intended for TT&C mostly.

[2] The most recent version of the applicable standard shall be used, unless stated otherwise.

[3] Applicable document for some signals are TBD (LNIS4-TBD-4025). Standards development is an ongoing effort.

[4] For high throughput Ka-band trunk links (> 200 Msps), higher order modulations and coding schemes are recommended to maximize bandwidth efficiency. VCM or a subset of the codes in the VCM standard can be considered.

[5] Code Division Multiple Access (CDMA) is currently being investigated and evaluated for possible use on X-band DTE links.

Table 11 - Codeword/Message Size for signals in Table 10

		Link														
		Direct-to-Earth														
		X Band								Ka Band						
Code	Rate	Codeword Size (Octets)	Message Size [4] (Octets)	XU1	XU2	XU3	XU4	XD1	XD2	XD3	XD4	Ka U1	Ka U2	Ka D1	Ka D2	
				PCM/FM/PSK phase L	GMSK+PN	PCM/PSK/FM +NRZ L	Filtered OQPSK/ GMSK	PCM/FM/PSK phase L	GMSK+PN	PCM/PSK/P M +NRZ L	Filtered OQPSK/ GMSK	Filtered OQPSK/ GMSK	Filtered OQPSK/ GMSK	Filtered OQPSK/ GMSK	Filtered OQPSK/ GMSK	Filtered OQPSK/ GMSK
				0.065 - 1.024	0.150 - 1.0 Mbps	0.0005 - 0.064 Mbps	0.128 - 10.0 Mbps	0.064 - 1.024	0.150 - 1.0 Mbps	0.0005 - 0.128 - 10.0	0.064 - 1.024	0.0005 - 0.128 - 10.0	2.0 - TBD	2.0 - TBD	1.0 - TBD	1.0 - TBD
LDPC [1], [2], [3]	1/2	64	32	X		X										
		256	128			X				X						
		4096	2048	X	X		X	X	X		X		X	X	X	X
	4/5	2560	2048	X	X		X	X	X		X	X	X	X	X	X
	7/8	1020	892	X	X		X	X	X		X	X	X	X	X	X
Uncoded		128			X					X						
		2048														

4.4 LNSP-User Terrestrial Interfaces

Table 12 - LNSP–User Terrestrial Link Layer Service Interfaces

Service Interface ID	Interface Type	Applicable Documents
SLE RAF	Space Link Extension Return All Frames	CCSDS 911.1-B-4
SLE RCF	Space Link Extension Return Channel Frames	CCSDS 911.2-B-3
SLE FCLTU	Space Link Extension Forward CLTU	CCSDS 912.1-B-4
CSTS FFS	Cross Support Transfer Service Forward Frame Service	CCSDS 922.3-R-1

5. LUNANET SERVICE PROVIDER TO LUNANET SERVICE PROVIDER SERVICES

5.1 LNSP A-LNSP B Communications Services

Using standard interfaces, an LNSP will be able to provide the communications services described in section 3.1. This will enable LunaNet communications service infrastructure to be provided by multiple providers. Beyond the user data, there will be communications between LNSPs for scheduling, routing, asset availability, and other functions.

5.2 LNSP A-LNSP B PNT Services

PNT services, as described in section 3.2 Position, Navigation, and Timing Services, may also be provided between assets belonging to two different LNSPs. This will be addressed in next version.

6. LUNANET SERVICE PROVIDER TO LUNANET SERVICE PROVIDER INTERFACES

6.1 LNSP A-LNSP B Lunar Surface Interfaces

These interfaces will follow the same standards as identified in section 4.1 LNSP-User Lunar Surface Interfaces.

6.2 LNSP A-LNSP B Crosslink Interfaces

To allow end-to-end delivery of data of user data, cross-link interfaces shall be based on DTN BP for the network layer. Crosslinks will allow two LNSPs to pass user data between their assets, message between the assets, and provide PNT services.

LunaNet providers will be required to directly exchange information within the internal architecture, independently from DTE interfaces, to enable awareness of the overall service health, availability and status, current and future schedule, and time synchronization. Direct exchange of information within the LunaNet architecture will also allow for the use of observables for self-navigation purposes. This section will cover the required interfaces between providers to ensure resilient services independent from Earth links. These crosslinks are to be carefully designed such that they are compatible with user links (TBD).

Table 13 - LNSP-LNSP Crosslink Layer Interfaces⁴

Interface Name	Interface Type	Targeted Frequency Range ³	Modulation ⁴	Coding ⁴	Applicable Documents ²
CFKa1	Crosslink Forward ¹	23.15 – 23.55 GHz (LNIS4-TBD-6001)	Filtered OQPSK and GMSK ²	LDPC rate 1/2 (4096 octets plus 64-bit ASM) LDPC code rate 4/5 (2560 octets plus 64-bit ASM) LDPC rate 7/8 (1020 octets plus 32-bit ASM)	
CRKa1	Crosslink Return ¹	27.00 – 27.50 GHz (LNIS4-TBD-6002)	Filtered OQPSK and GMSK ²	LDPC rate 1/2 (4096 octets plus 64-bit ASM) LDPC code rate 4/5 (2560 octets plus 64-bit ASM) LDPC rate 7/8 (1020 octets plus 32-bit ASM)	

Notes:

[1] The “forward” or “return” designation is determined by the source and destination of a particular signal. If a signal originates at a lunar region user (orbiter, rover, lander, etc.) and is sent to LNSP-A, any subsequent links to LNSP-B, LNSP-C, etc. before being routed to a mission or science operations center

would be at a “return” frequency (27.0 – 27.5 GHz). If data was sent by a science or mission operations via an LNSP Earth station, then passed around nodes within an LNSP network before being delivered to a lunar region user, the links between LNSP nodes in this case would be at a “forward” frequency (23.15 – 23.55 GHz). Each LNSP will have the capability to transmit as well as receive crosslink signals from fellow LNSPs that are part of the service provider network.

[2] CCSDS preliminary recommendation 2.2.10 on “High-Rate Space-to-Space Links, Space Research and Inter-Satellite.”

[3] Exact center frequency to be determined based on user requirements, conops, and are subject to coordination.

[4] Preliminary recommendations (TBD)

6.3 LNSP A-LNSP B DTE Interfaces

These interfaces will follow the same standards as identified in 4.3 LNSP-User DTE Interfaces.

6.4 LNSP A-LNSP B Terrestrial Interfaces

These interfaces will follow the same standards as identified in section 4.4 LNSP-User Terrestrial Interfaces.

REFERENCES

- [RD1] Anzalone, E., et al. “Lunar Navigation Beacon Network using GNSS Receivers”, Proceedings of the 70th International Astronautical Congress (IAC), Washington, DC, October 2019.
- [RD2] Ashman, B., et al. “Exploring the Moon with GNSS: Applications of GNSS within and Beyond the Space Service Volume.”
- [RD3] CCSDS, 730.1-G-1, Solar System Internetwork (SSI) Architecture, Informational Report, Green Book, Issue 1, July 2014.
- [RD4] Cheung, K., Lee, C., “Lunar Relay Coverage Analysis for RF and Optical Links,” AIAA SpaceOps 2018 Conference, 31 May 2018.
- [RD5] D. J. Israel et al., "LunaNet Architecture and Concept of Operations," The 16th International Conference on Space Operations (SpaceOps 2021), 2021.
- [RD6] Dille, M., et al. “PHALAX: Expendable Projectile Sensor Networks for Planetary Exploration”, 2020 IEEE Aerospace Conference, Big Sky, MT, 2020.
- [RD7] Ely, T., et al. “The Deep Space Atomic Clock Mission”, 23rd International Symposium on Space Flight Dynamics, Pasadena, California, October 29 - November 2, 2012, <http://hdl.handle.net/2014/43016>.
- [RD8] Heckler, G., Gramling, C., Donaldson, J., Baldwin, P., “TDRSS Augmentation Service for Satellites,” Proceedings of the 14th International Conference on Space Operations, 16-20 May 2016, Daejeon, Korea
- [RD9] International Communication System Interoperability Standards (ICSIS) Rev A, September 2020.
- [RD10] IOAG “Space Internetworking Strategy Group (SISG) Recommendations on the Selection of End-to-end Space Internetworking Protocol,” IOAG Report, February 2021.
- [RD11] IOAG “The Future Lunar Communications Architecture v1.3,” Report of the IOAG Lunar Communications Architecture Working Group, January 2022.
- [RD12] Israel, D. et al., “LunaNet: A Flexible and Extensible Lunar Exploration Communications and Navigation Infrastructure,” IEEE Aerospace Conference, Big Sky, MO, 2020
- [RD13] Israel, D. et al., “The Benefits of Delay/Disruption Tolerant Networking (DTN) for Future NASA Science Missions” Proceedings of the 70th International Astronautical Congress (IAC), Washington, DC, October 2019.
- [RD14] Israel, D., Mauldin, K., et al., “LunaNet: A Flexible and Extensible Lunar Exploration Communications and Navigation Infrastructure and the Inclusion of SmallSat Platforms,” 34th Annual Small Satellite Conference
- [RD15] Johnson, S., Vitalpur, S., Tai, W., Schier, J., Bussey, D. B., Bleacher, J. E., “Communications Interoperability for Lunar Missions”, 70th International Astronautical Congress (IAC), Washington, D. C., October 2019.

- [RD16] McCabe, J., and DeMars, K., "Anonymous Feature-Based Terrain Relative Navigation." *Journal of Guidance, Control, and Dynamics* 43.3 (2020): 410-421.
- [RD17] Mills, D. et al. *Computer Network Time Synchronization: The Network Time Protocol on Earth and in Space*. CRC press, 2017.
- [RD18] Riedel, J. E., et al. "Autonomous Optical Navigation (AutoNav) DS 1 technology validation report." *Deep Space 1 Technology Validation Reports*, Pasadena, CA, Jet Propulsion Laboratory, 2000.
- [RD19] Small, J., Mann, L., Crenshaw, J., Gramling, C., Rosales, J., Winternitz, L., Hassouneh, M., Baker, D. Hur-Diaz-S., Liounis, A. "Lunar Relay Onboard Navigation Performance and Effects on Lander Descent to Surface," Institute of Navigation International Technical Meeting, January 2022.
- [RD20] Valdez, J., Ashman, B., Gramling, C., Heckler, G., "Navigation Architecture for a Space Mobile Network," *Proceedings of the 39th American Astronautical Society Guidance and Control Conference*, Breckenridge, CO, 5-10 February 2016.
- [RD21] Wallace, T., InKyu, K., SangMan, M., Day K, Kar-Ming C., "The Lunar Space Communications Architecture from the KARI-NASA Joint Study," *AIAA SpaceOps 2016 Conference*, 6 May 2016
- [RD22] Winternitz, L., et al. "Global Positioning System Navigation above 76,000Km for NASA's Magnetospheric Multiscale Mission." *Navigation: Journal of the Institute of Navigation* 64.2 (2017): 289-300.
- [RD23] European GNSS (Galileo), *Galileo Service Definition Document*, issue 1.2, November 2021
- [RD24] *Radio Frequency and Modulation Systems -Part 1 Earth Stations and Spacecraft*, Blue Book, Issue 32, CCSDS 401.0-B-32, October 2021.
- [RD25] Vilnrotter, V., Hamkins, J., "Telecommand/Telemetry Ranging for Deep Space Applications," *IEEE Aerospace Conference*, January 14, 2019.

APPLICABLE DOCUMENTS

- [AD1] LunaNet and User Signal Structure Definition Document (LNIS4-TBD-AD0001)
- [AD2] LunaNet Measurement Schema and Parameters Document (LNIS4-TBD-AD0002)
- [AD3] LunaNet Detailed Message Definition Document (LNIS4-TBD-AD0003)
- [AD4] LunaNet Location Services for Users Document (LNIS4-TBD-AD0004)
- [AD5] Lunar Reference Frame Standard (LNIS4-TBD-AD0005)
- [AD6] Lunar Time System Standard (LNIS4-TBD-AD0006)
- [AD7] LunaNet LunaSAR Definition Document (LNIS4-TBD-AD0007)
- [AD8] LunaNet Interoperability Security Specifications (LNIS4-TBD-AD0008)

Other relevant documents:

CCSDS 702.1-B-1
CCSDS 734.1-B-1
CCSDS 133.1-B-3
CCSDS 414.1-B-2
CCSDS 415.1-B-1
CCSDS 911.1-B-4
CCSDS 911.2-B-3

CCSDS 912.1-B-4
CCSDS 922.3-R-1
CCSDS 732.1-B-2
CCSDS 231.0-B-4
CCSDS 401.0-B-31
CCSDS 131.0-B-3
CCSDS 231.0-B-4

Appendix A. LunaNet Interoperability Specification Phase Allocations

Table A-1 Phase Allocations

Section	Name	IOC	Sustaining
3.1.1.1	Real-Time Link Layer Communications Services	X	X
3.1.1.2	Real-Time Network Layer Communications Services	X	X
3.1.2	Store-and-Forward Communications Services	X	X
3.1.3	Messaging Services		X
3.2.1.1	One-Way Doppler Reference (1wDRef)	X	X
3.2.1.2	Pseudo-Range and Timing Reference (1wRTRef)	X	X
3.2.1.3	Time-Transfer Reference (Tref)	X	X
3.2.2	Lunar Augmented Navigation System (LANS)	X	X
3.2.3.1	One-Way Doppler Measurement (1wDMeas)		X
3.2.3.2	Pseudo-Range Measurement (1wRTMeas)		X
3.2.4.1	Two-Way Doppler Measurement (2wDMeas)	X	X
3.2.4.2	Range Measurement (2wRMeas)	X	X
3.2.5.1	Two-Way Coherent Doppler Transponder (2wD-XPND)		X
3.2.5.2	Non-Regenerative Range Transponder (2wNRR-XPND)		X
3.2.5.3	Regenerative Range Transponder (2wRR-XPND)		X
3.2.6	Supplemental Navigation Products (NavSupp)	X	X
3.2.7	Location Service (Loctn)		X
3.3.1	Lunar Search and Rescue (LunaSAR) Services		X
3.3.2	Space Weather Alerting Services		X
3.4	Science Services		X
3.5.1	Earth-based Scheduling Interface	X	X
3.5.2.1	Multiple Access Forward Link/Augmented Forward Signal (AFS) Service	X	X
3.5.2.2	Multiple Access Return Link		X
3.5.2.3	User Initiated Services		X
3.5.3	User Initiated Services		X
4.1	LNSP-User Lunar Surface Interfaces	X	X
4.2	LNSP-User Proximity Interfaces (PFS1a-c, PFS5, PRS1a-c, PRS5, PFKa1, PRKa1)	X	X
4.2	LNSP-User Proximity Interfaces (All other interfaces except PFS1a-c, PFS5, PRS1a-c, PRS5, PFKa1, PRKa1)		X
4.3	LNSP-User DTE Interfaces (XU1, XD1, KaU1, KaD1)	X	X
4.3	LNSP-User DTE Interfaces (All other interfaces except XU1, XD1, KaU1, KaD1)		X
4.4	LNSP-User Terrestrial Interfaces	X	X
5.1	LNSP A-LNSP B Communications Services		X
5.2	LNSP A-LNSP B PNT Services		X
6.1	LNSP A-LNSP B Lunar Surface Interfaces		X
6.2	LNSP A-LNSP B Crosslink Interfaces		X
6.3	LNSP A-LNSP B DTE Interfaces		X

6.4	LNSP A-LNTP B Terrestrial Interfaces		X
-----	--------------------------------------	--	---

Appendix B. Acronyms and Abbreviations

Table B-1 Acronyms and Abbreviations

Acronym	Description
3GPP	3rd Generation Partnership Project
AFS	Augmented Forward Signal
AOS	Advanced Orbiting Systems
ASM	Attached Sync Marker
BP	Bundle Protocol
BPSK	Binary Phase Shift Key
CBOR	Concise Binary Object Representation
CLPS	Commercial Lunar Payload Services
CCSDS	Consultative Committee for Space Data Systems
CDMA	Code Division Multiple Access
CLTU	Command Link Transmission Unit
DEM	Digital Elevation Maps
DTE	Direct to Earth
DTN	Delay/Disruption Tolerant Networking
DVB-S2	Digital Video Broadcasting-Second Generation
EOC	Enhanced Operational Capability
ESC	Exploration and Space Communication
EVA	Extravehicular Activity
GMSK	Gaussian Minimum Shift Keying
GNSS	Global Navigation Satellite System
ICAO	International Civil Aviation Organization
ICMP	Information and Configuration Management Plan
IETF	Internet Engineering Task Force
IMO	International Maritime Organization
IOAG	Interagency Operations Advisory Group
IOC	Initial Operational Concept
IP	Internet Protocol
KSPS	Kilo Symbols Per Second
LANS	Lunar Augmented Navigation System
LDPC	Low Density Parity Check
LNS	LunaNet System
LNSP	LunaNet Service Providers
LTP	Licklider Transmission Protocol
MAR	Multiple-Access-Return
MHZ	Megahertz

MOC	Mission Operations Center
NPD	NASA Policy Directives
NPR	NASA Procedural Requirements
NRZ-L	Nonreturn-To-Zero Level
NTP	Netrix Trunk Protocol
OQPSK	Offset Quadrature Phase Shift Keying
P2P	Point to Point
PN	Pseudo-Noise
PNT	Position, Navigation, Timing
PVT	Position, Velocity, Timing
RD	Reference Document
RF	Radio Frequency
RFC	Radio Frequency Compatibility
SAR	Search and Rescue
SCaN	Space Communications and Navigation
SCCC	Spacecraft Command and Control Center
SS-BPSK	Spread Spectrum Binary Phase-Shift Keying
TBD	To Be Determined
TBR	To Be Refined
TCP/IP	Transmission Control Protocol/Internet Protocol
UDP	User Datagram Protocol
VCM	Variable Coding and Modulation
Wi-Fi	Wireless Fidelity

Appendix C. Detailed Signal Definitions

Augmented Forward Signal Structure (PFS5)

The AFS service is enabled using a spread spectrum signal structure similar to the ones used in GNSS, allowing significant reuse of GNSS spaceborne receivers. The signal will be broadcast in the 2483.5-2500 MHz frequency range, being the band designed for radionavigation in recommendation REC 32.2R3 from the SFCG [AD7]. CDMA allows different LunaNet sources to provide the AFS service simultaneously at a single and common S-band frequency, and individual, orthogonal PN codes will be assigned to each LNSP node implementing this service. [AD1] will identify the method to assign PN codes to LNSP nodes.

Modulations adopted will be in line with current GNSS signals, by utilizing Bi-Phase Shift Keying (BPSK) and/or Binary Offset Carrier (BOC) modulations. Two channels are foreseen, one in-phase (I) and one in quadrature phase (Q). The I-channel is intended to facilitate acquisition, navigation capabilities, and serve as a data channel. The I-channel will consist of a BPSK (1) modulation, utilizing a spreading code at 1.023 Mcps. The data channel is used to disseminate LunaNet messages, carrying navigation, general access, alerts, and SAR information. The Q-channel is intended to provide higher accuracy PNT services, in the form of a pilot channel, carrying no data and employing different PN codes to maximize cross-correlation properties. Modulation currently under consideration for the Q-channel are BPSK (5) with a spreading code at 5.115Mcps or BOC(5, 2) with an offset carrier at 5.115MHz and a spreading code at 2.046Mcps. Chip-rates for both channels will be synchronized with each other and coherently related to a mutual carrier frequency reference. Given the limited allocated frequency range for the AFS, modulation selections are constrained based on their frequency bandwidth requirements. The values of 5.115Mcps for BPSK(5) and subcarrier of 5.115MHz for BOC(5,2) are under consideration as they both meet this constraint.

To transmit a carrier center frequency of 2492.028 MHz, the reference clock can be at 1.023MHz utilizing a reference clock multiplier of 2436. The detailed definition of the signal is provided in LunaNet and User Signal Structure Definition Document [AD1]. The AFS data rate is expected to be between 250sps and 1ksps (LNIS4-TBR-AP0001). It is important to note that the data symbol length shall never be shorter than the CDMA primary code length (e.g., if the data rate is 1ksps, the primary code length should be at most 1ms; if the data rate is 250 sps, the primary code length should be at most 4 ms). Note that this signal structure and the LANS service in section 3.2.2 will be used for all LunaNet nodes broadcasting the AFS/PFS5 signal.

Messages that will be transmitted as part of AFS on PFS5 are identified in Appendix D.

Each LNSP shall ensure the AFS maintains Signal-In-Space-Errors (SISE) within the requirement specified in Table C-1 within the defined service volume.

The SISE is defined as the instantaneous difference between the position, velocity and time of a LunaNet node as broadcasted by that node's navigation message and the true satellite PVT respectively expressed in the lunar reference frame [AD5] and the lunar time system standard [AD6].

This definition is agnostic of the orbital characteristics of each LunaNet node and establishes an upper bound on the error experienced at user level that is the result of the projection of the SISE onto the user-satellite direction [RD 25].

This allows users to derive consistent and reliable navigation solutions when using LANS from different LNSPs. The SISE consists of a combination of errors that are the responsibility of the LNSPs, such as:

1. LNSP ephemeris uncertainties or errors in the orbital products tendered to users, as represented in the lunar reference frame.
2. LNSP timing errors due to time knowledge uncertainties, inaccurate clock correction information conveyed to users, or misalignments of time with the signal realization.
3. Uncalibrated or unknown LNSP group delays due to code phase offsets, antenna phase offsets and variations, unaccounted transmit path delays and variations, code-to-code incoherency, code-to-carrier incoherency, etc.

The SISE can be expressed for convenience in two parts:

1. Signal-In-Space Error for positioning (SISE pos)

$$SISE_{pos} = \sqrt{(x - \tilde{x})^2 + (y - \tilde{y})^2 + (z - \tilde{z})^2 + (ct - c\tilde{t})^2}, \quad 1$$

Where x, y, z, t are the true position and time, while the corresponding tilde parameters represent the values broadcasted in the navigation message.

2. Signal-In-Space Error for velocity (SISE vel):

$$SISE_{vel} = \sqrt{(\dot{x} - \tilde{\dot{x}})^2 + (\dot{y} - \tilde{\dot{y}})^2 + (\dot{z} - \tilde{\dot{z}})^2 + (c\dot{t} - c\tilde{\dot{t}})^2}, \quad 2$$

Where $\dot{x}, \dot{y}, \dot{z}$ represents the velocity and $c\dot{t}$ the clock drift.

Table C-1 LNSP SISE

Error	Value
SISE pos	≤TBD m (99%) - Calculated as the 99th percentile of the time series of instantaneous SISE values over a TBD hours period.
SISE vel	≤TBD m/s (99%) - Calculated as the 99th percentile of the time series of instantaneous SISE values over a TBD hours period.

Multiple Access Return Signal Structure (PRS5)

The Multiple-Access-Return (MAR) service is enabled using a spread spectrum signal, CDMA. This allows different users to approach the LunaNet network simultaneously at a single and common TBD frequency, as each source is assigned a different PN sequence pattern.

The MAR service is enabled using a TBD CDMA signal structure. To support simultaneous use of the MAR channel allocation, special considerations may be required to maximize the ability for LunaNet to detect, acquire, and track the signals. Transmission of signals by users will be limited to the purposes of requesting services or conveying situational-awareness messages and SAR alerts.

The signals are to be transmitted for discrete, short periods of time (TBD). The signal power provided by users to the MAR channel will be transmitted with a minimum power of TBD and a maximum power of TBD. Additionally, information rates provided via MAR are limited to TBD bps.

Messages that can be transmitted via MAR on PRS5 will be identified in Appendix D.

Navigation Reference and Measurement Services VS Communication links

Tables C-6 and C-7 provide a relationship of navigation reference and measurement services as described in section 3.2. Link types beyond those identified for LunaNet interoperability are included for completeness.

Table C-6 - Navigation Reference and Measurement Services versus Forward Communication Links

PNT Service ID	Services	Band-Direction	S-Forward							Ka-Forward	Ka-Forward	Ka-Forward	Ka-Forward
		Modulation	BPSK	PCM/PM/bi-phase-L with PN ranging	PCM/PSK/PM +NRZ-L with PN ranging Sinewave subcarrier frequency=max (4Rs, 8kHz)	Filtered OQPSK/GMSK for high rates	GMSK + PN Ranging	SS-BPSK or SS-UQPSK (10:1) CCSDS 415.1-B-1	AFS (Augmented Forward Signal)	BPSK or OQPSK	DVB-S2, SCCC, or LDPC-VCM	Filtered OQPSK/ GMSK	GMSK + PN Ranging
		Ranging	No	PN CCSDS 414.1-B-2	PN CCSDS 414.1-B-2	No	Yes	CDMA PN	CDMA PN	Potential for telemetry ranging	Potential for telemetry ranging	Potential for telemetry ranging	CCSDS 413.1-G-1 (TBD) PN CCSDS 414.1-B-2 (TBD)
		Symbol Rates Supported	2 ksps < Rs < 2 Msps	48 ksps < Rs < 1.024 Msps	0.5 ksps < Rs < 48 ksps	1 Msps < Rs < 5 Msps	1 Msps < Rs < 5 Msps	Rs <= 300 ksps (TBR)	250 <= Rs <= 1 kbps (TBD)	1 Msps < Rs < TBD	1 Msps < Rs < TBD	1 Msps < Rs < TBD	1 Msps < Rs < TBD
Interop Signal ID	PFS1a	PFS1b	PFS1c	PFS1d	PFS1e	PFS2	PFS5	PFKa1	PFKa2	PFKa3	PFKa4		
1wDRef	1-Way FWD Doppler Reference	X	X	X	X	X	X	X	X	X	X	X	
1wRTRef	FWD Pseudo-Range and Timing Reference		Potential	Potential				X	Potential	Potential	Potential	Potential	
1wDMeas	1-Way RTN Doppler Measurement												
1wRTMeas	RTN Pseudo-Range Measurement												
2wDMeas	2-Way Doppler Measurement	X	X	X	X	X	X		Potential Need Turn-Around defined	Potential Need Turn-Around defined	Potential Need Turn-Around defined	Potential Need Turn-Around defined	
2wRMeas	2-Way Range Measurement		X	X			X	X	Potential Need Turn-Around defined	Potential Need Turn-Around defined	Potential Need Turn-Around defined	Potential Need Turn-Around defined	
2wD-XPND	2-Way Coherent Doppler Transponder	X	X	X	X	X	X		Potential Need Turn-Around defined	Potential Need Turn-Around defined	Potential Need Turn-Around defined	Potential Need Turn-Around defined	
2wNRR-XPND	Non-Regenerative Range Transponder		X	X			X						
2wRR-XPND	Regenerative Range Transponder		Potential	Potential			X					X	
TRef	FWD Time Transfer		Potential	Potential			Potential	Potential	X	Potential	Potential	Potential	
LANS	Lunar Augmented Navigation Service (LANS) (Simultaneous AFS by More Than 1 Relay)								X				

Table C-7 - Navigation Reference and Measurement Services versus Return Communication Links

PNT Service ID	Services	Band-Direction	S-Return							Ka-Return	Ka-Return	Ka-Return	Ka-Return
		Modulation	BPSK	PCM/PM/bi-phase-L	PCM/PSK/PM +NRZ-L with PN ranging Sinewave subcarrier frequency=max (4Rs, 8 kHz)	Filtered OQPSK/GMSK for high rates	GMSK + PN Ranging	SS-BPSK CDMA (~3Mcps) or SS-SQPN	SS-BPSK CDMA (~3Mcps) or SS-UQPSK Multiple Access Return	BPSK or OQPSK	DVB-S2, SCCC, or LDPC-VCM	Filtered OQPSK/ GMSK	GMSK + PN Ranging
		Ranging	No	PN CCSDS 414.1-B-2	PN Ranging	TBD	TBD	CDMA PN	CDMA PN	Potential for telemetry ranging	Potential for telemetry ranging	Potential for telemetry ranging	CCSDS 413.1-G-1 (TBD) PN CCSDS 414.1-B-2 (TBD)
		Symbol Rates Supported	2 ksps < Rs < 2 Msps	48 ksps < Rs < 1.024 Msps	0.5 ksps < Rs < 48 ksps	1 Msps < Rs < 5 Msps	1 Msps < Rs < 5 Msps	TBD	TBD	1 Msps < Rs < TBD	1 Msps < Rs < TBD	1 Msps < Rs < TBD	1 Msps < Rs < TBD
Interop Signal ID	PRS1a	PRS1b	PRS1c	PRS1d	PRS1e	PRS2	PRS5	PRKa1	PRKa2	PRKa3	PRKa4		
1wDRef	1-Way FWD Doppler Reference												
1wRTRef	FWD Pseudo-Range and Timing Reference												
1wDMeas	1-Way RTN Doppler Measurement	X	X	X	X				Potential	Potential	Potential	Potential	
1wRTMeas	RTN Pseudo-Range Measurement			Potential					Potential	Potential	Potential	Potential	
2wDMeas	2-Way Doppler Measurement	X	X	X	X	X	X	Potential	Potential Need Turn-Around defined	Potential Need Turn-Around defined	Potential Need Turn-Around defined	Potential Need Turn-Around defined	
2wRMeas	2-Way Range Measurement						X		Potential	Potential	Potential	Potential Need Turn-Around defined	
2wD-XPND	2-Way Coherent Doppler Transponder	X	X	X	X	X	X		Potential	Potential	Potential	Potential	
2wNRR-XPND	Non-Regenerative Range Transponder		X	X			Potential						
2wRR-XPND	Regenerative Range Transponder		Potential	Potential			Potential	X				Potential Need Turn-Around defined	
TRef	FWD Time Transfer												
LANS	Lunar Augmented Navigation Service (LANS)												

Appendix D. LunaNet Application Messages

Overview of Messages

Messaging services provide a standard method for information to be transferred directly over a link layer service, a network layer service, or via dedicated message streams (e.g., AFS messages). These messaging services are utilized by protocols for PNT services, network acquisition, space weather alerts, search and rescue, and other LunaNet services. Standard messages are envisioned to be used across user proximity links, provider crosslinks, as well as DTE links.

At this time, the application of messages to the P2P links and crosslinks have not been fully defined. Thus, it is relevant to note that the particulars of the messages on these link types may differ slightly from those on the AFS.

LunaNet Detailed Message Definition Document (LNIS4-TBD-AD0003) [AD3] will specify all message formats, content, parameters, and association with each service and/or signal. An overview is provided herein, starting with Table D-1 that lists the message ID, message title, and a brief description.

Table D-1. Message Identification

MSG ID	MSG Title	Description
MSG-G1	LunaNet Network Access Information	Identifies attributes needed to access network services. Informs users of basics applicable to LN provider nodes, such as services offered and bands, update rate of messages. May include other messages plus additional info, such as almanac, MLNAntennaProperties, H&S.
MSG-G2	Health and Safety	Health status of the service(s) provided by the LNSP node and is specific to the LNSP node. Health status of other LNSP nodes is provided as part of MSG-G5 MORbitAlmanac.
MSG-G3	MAntennaProperties	Information about the transmission antenna properties (e.g.: antenna offset from CG in body frame, articulating or static, proximity signal FOVs, attitude (3-axis, nadir, or other)). Default information can be specified in the standard. LNSP must identify default values of the antenna properties in their ICDs. If a LNSP is fully compliant with the default values in the ICDs this message might be omitted. On the contrary, if the LNSP is not compliant with the default specification, they shall disseminate this message. At the user level, this is transparent: the user will receive the messages and interpret them as needed.
MSG-G4	Sorbit Ephemeris & clock correction	Precise ephemeris, path delays, and clock corrections of the LunaNet satellite that is transmitting the signal. This message will also contain (if required) the clock offset between the LNSP time to the lunar reference time. This is specific for PNT, not to be confused with MSG-G5 MORbitAlmanac. The message will broadcast the parameters to be used in the orbital model defined in the LNSP specific documentation (e.g., ICD).

MSG-G5	MOrbit Almanac	Parameters of the orbital model (low accuracy model, ~km orbit position accuracy, ~m/s orbit velocity accuracy) of all the satellites in the LNSP constellation. This message will also (optionally, TBD) include the health status of the services provided by all the LNSP nodes.
MSG-G6	SOrbit Almanac	Parameters of the orbital model (low accuracy model on the order of km orbital position accuracy and m/s orbital velocity accuracy) of the LNSP node transmitting the signal.
MSG-G7	SOrbitState / Location	Location Service information to user, whether on surface or in orbit.
MSG-G8	Time and Frequency Synchronization (fine)	Time of week (TBD) information and the center frequency of the transmitted signal. Time is provided at the defined edge of a synchronization symbol within the navigation message.
MSG-G9	Time and Frequency Synchronization (frame)	Time of week (TBD) information and the center frequency of the transmitted signal. Time is provided at the defined edge of a synchronization frame within the navigation message.
MSG-G10	Maneuver	Announces a planned maneuver of a LunaNet satellite to the users and network, or of a user to LunaNet for Location Service.
MSG-G11	SAttitude State/ Ephemeris	Attitude information of the satellite. This message could implement the parameters of an attitude model to allow the user to compute the current and future attitude of the TX satellite. Alternatively, a time series of already computed attitude information could be broadcast to the user.
MSG-G12	MAttitudeEphem	Attitude information of multiple satellites, e.g., the constellation of LunaNet provider nodes.
MSG-G13	Observations	Information on metric tracking measurements (observations) performed by one entity that is forwarded to a separate entity.
MSG-G14	Conjunction	Announces a potential conjunction between lunar orbiters. This concept could be like the CCSDS standard for Conjunction Data Message exchanges.
MSG-G15	Maplet	Map information for specific selenographic sectors or seleno-global. Details to be worked on specific content; concepts include sector index ID, current versions, delta update information from reference to limit dissemination time.
MSG-G16	Map Comprehensive	Full high resolution digital elevation map for specific lunar surface selenographic sector(s).
MSG-G17	Ancillary info	Basic data required for PNT, for example reference frames, coordinate transformations, lunar potential models, covariance, and state transition matrix.
MSG-S18	Search and Rescue Alert	Alert from Search and Rescue beacon.
MSG-S19	Acknowledge- of SAR - LvL1	Automatic acknowledge at the LunaNet satellite level of receipt of a SAR beacon distress msg. This does not mean the message has been processed by the SAR ground system.

MSG-S20	Acknowledge- of SAR - LvL2	Acknowledgement that the SAR beacon alert request has been correctly received at the control center and that a rescue operation has started (also called LunaSAR return message).
MSG-G21	User Message Request	Request by user for specific message.
MSG-G22	Acknowledge- of non-SAR MSG	Automatic acknowledge at the LunaNet satellite level of receipt of a user request (non-SAR). Note that this is not the response to the request, but simply an acknowledgement of receipt.
MSG-G23	GNSS Augmentation	Augmentation information (e.g., satellites ephemeris) on Earth GNSS satellites to support the use of Earth GNSS signals by GNSS sensitive receivers in cislunar.
MSG-G24	Detection Alert	Used to broadcast an alert that must be disseminated to the users.
MSG-G25	Science	Disseminates science-specific data.
MSG-G26	UIS Request	Request from user for services from LunaNet.
MSG-G27	UIS Response	Notification to user indicating response to the UIS Request.
MSG-G28	User Schedule Notice	Notification to user of upcoming service schedule that needs to be disseminated to ensure receipt prior to an upcoming P2P contact.
MSG-G29	FF Commands	Specific user commands or information needed rapidly by user, distributed via broadcast.

Table D-2 provides the following information for each message transmitted via AFS.

Under each PNT sub-service, a label is used to identify which category applies to that message/service combination within the available AFS bandwidth: F = Fundamental, meaning it shall be broadcasted by the LNSP; O = Optional, meaning it might be broadcasted by the LNSP; and C = Comm, meaning it can be transmitted on AFS to facilitate LunaNet services. In the table below, Table D-2, fields that are grey with a dash indicate the fact that the message is not provided over the service link.

- **Periodicity:** “Periodic” means the message is transmitted at a regular cadence; “ad-hoc” means the message is sent only when needed or requested.
- **Cadence:** Identifies the time between consecutive transmission of periodic messages with the same message ID (e.g., MSG-Gx). Note: the message information may not be updated at this cadence, the actual data may be static on successive transmissions.
- **Latency:** Identifies the time between message generation/reception and message transmission. If marked N/A, there is no stringent requirement from an interoperability standpoint.

Table D-2. LANS / AFS Messages

Message ID	DESCRIPTION	Periodicity	Cadence	Latency	LANS via AFS								
					SERVICE		PNT			Detection		Network	
					SUB SERVICE	1wDRef	1wRTRef	TRef	Nav Supp	SAR	Alert	Net	Comm
Message Title				1-Way Doppler Reference	Pseudo-Range and Timing Reference	Time Transfer Reference	Supplemental Navigation Products	Search and Rescue	Alert Notice to User	Network Attributes	User Communication		
MSG-G1	LunaNet Network Access Information	Periodic (TBC)	TBD	TBD							F		
MSG-G2	Health and Safety	Periodic	1sec to 1min (TBC)	TBD							F		
MSG-G3	M Antenna Properties	TBD	N/A	TBD							O		
MSG-G4	SOrbit Ephemeris+ Clock correction	Periodic	1sec to 5min	TBD	F	F	F						
MSG-G5	M Orbit Almanac	Periodic	1min to 20 min (TBC)	N/A				F					
MSG-G6	SOrbit Almanac	N/A	N/A	N/A	--	--	--	--	N/A	N/A	--	--	
MSG-G7	SOrbit State / Location	N/A	N/A	N/A	--	--	--	--	--	--	--	--	
MSG-G8	Time and Frequency Synchronization (fine)	Periodic	1-10 sec	ms to 1 sec	F	F	F						
MSG-G9	Time and Frequency Synchronization (frame)	N/A	N/A	N/A	--	--	--	--	--	--	--	--	
MSG-G10	Maneuver	ad-hoc	1min thru maneuver	advance thru maneuver				O					
MSG-G11	SAttitude State/Ephemeris	Ad-hoc	N/A	TBD				O					
MSG-G12	MAttitudeEphem	N/A	N/A	N/A	--	--	--	--	--	--	--	--	
MSG-G13	Observations	N/A	N/A	N/A	--	--	--	--	--	N/A	--	--	
MSG-G14	Conjunction	Ad-hoc	N/A	TBD time before conjunction				O					
MSG-G15	Maplet	Ad-hoc	N/A	N/A				O					
MSG-G16	Map Comprehensive	N/A	N/A	N/A	--	--	--	--	--	N/A	--	--	
MSG-G17	Ancillary info	Ad-hoc	N/A	N/A				O					
MSG-S18	Search and Rescue Alert	N/A	N/A	N/A	--	--	--	--	--	--	--	--	
MSG-S19	Acknowledge- of SAR - Lv L1	Ad-hoc	N/A	reception at LNSP node					F				
MSG-S20	Acknowledge- of SAR - Lv L2	Ad-hoc / periodic (TBD)	N/A	1-10 min (TBC) from LunaNet constellation reception of the SAR Operations Center response					F				
MSG-G21	User Message Request	N/A	N/A	N/A	--	--	--	--	--	--	--	--	
MSG-G22	Acknowledge- of non-SAR MSG	Ad-hoc	N/A	request reception at LNSP node								O	
MSG-G23	GNSS Augmentation	Periodic	TBD	TBD				O					
MSG-G24	Detection Alert	Ad-hoc / periodic (TBD)	N/A	1-10 min (TBC) from reception of the alert						O			
MSG-G25	Science	TBD	TBD	TBD								C	
MSG-G26	UIS Request	N/A	N/A	N/A	--	--	--	--	--	--	--	--	
MSG-G27	UIS Response	Ad-hoc	N/A	TBD								C	
MSG-G28	User Schedule Notice	Ad-hoc	N/A	TBD								C	
MSG-G29	FF Commands	Ad-hoc	N/A	TBD								C	