

## Recommendation for Space Data System Standards

**DATA TRANSMISSION AND**  
**PN RANGING FOR 2 GHZ**  
**CDMA LINKS, INCLUDING**  
**RELAY AND LUNAR**

**RECOMMENDED STANDARD**

**CCSDS 415.1-BP-1**

**BLUE BOOK**  
**~~September 2011~~ May 2023**



## AUTHORITY

Issue:	Recommended Standard, Issue 1
Date:	September 2011
Location:	Washington, DC, USA

This document has been approved for publication by the Management Council of the Consultative Committee for Space Data Systems (CCSDS) and represents the consensus technical agreement of the participating CCSDS Member Agencies. The procedure for review and authorization of CCSDS documents is detailed in the *Procedures Manual for the Consultative Committee for Space Data Systems*, and the record of Agency participation in the authorization of this document can be obtained from the CCSDS Secretariat at the address below.

This document is published and maintained by:

CCSDS Secretariat  
Space Communications and Navigation Office, 7L70  
Space Operations Mission Directorate  
NASA Headquarters  
Washington, DC 20546-0001, USA

## STATEMENT OF INTENT

The Consultative Committee for Space Data Systems (CCSDS) is an organization officially established by the management of its members. The Committee meets periodically to address data systems problems that are common to all participants, and to formulate sound technical solutions to these problems. Inasmuch as participation in the CCSDS is completely voluntary, the results of Committee actions are termed **Recommended Standards** and are not considered binding on any Agency.

This **Recommended Standard** is issued by, and represents the consensus of, the CCSDS members. Endorsement of this **Recommendation** is entirely voluntary. Endorsement, however, indicates the following understandings:

- o Whenever a member establishes a CCSDS-related **standard**, this **standard** will be in accord with the relevant **Recommended Standard**. Establishing such a **standard** does not preclude other provisions which a member may develop.
- o Whenever a member establishes a CCSDS-related **standard**, that member will provide other CCSDS members with the following information:
  - The **standard** itself.
  - The anticipated date of initial operational capability.
  - The anticipated duration of operational service.
- o Specific service arrangements shall be made via memoranda of agreement. Neither this **Recommended Standard** nor any ensuing **standard** is a substitute for a memorandum of agreement.

No later than five years from its date of issuance, this **Recommended Standard** will be reviewed by the CCSDS to determine whether it should: (1) remain in effect without change; (2) be changed to reflect the impact of new technologies, new requirements, or new directions; or (3) be retired or canceled.

In those instances when a new version of a **Recommended Standard** is issued, existing CCSDS-related member standards and implementations are not negated or deemed to be non-CCSDS compatible. It is the responsibility of each member to determine when such standards or implementations are to be modified. Each member is, however, strongly encouraged to direct planning for its new standards and implementations towards the later version of the Recommended Standard.

## FOREWORD

This document is a technical Recommended Standard for use in developing spread spectrum modulation systems and has been prepared by the Consultative Committee for Space Data Systems (CCSDS). The spread spectrum modulation concept described herein is intended for missions that are cross-supported between Agencies of the CCSDS.

The spread spectrum modulation systems currently used by the Space Network Interoperability Panel (SNIP) agencies involve Direct Sequence Spread Spectrum (DSSS) in the form of pseudo-random noise (PN) Gold codes and Maximal Length codes. The PN code libraries used by NASA Users are also shared by Users of the European Space Agency (ESA) and Japan Aerospace Exploration Agency (JAXA). Included in this Recommended Standard are proposed techniques for expanding the code libraries for additional CCSDS Users. The expanded code library fits into the existing SNIP architecture.

Attention is drawn to the possibility that some of the elements of this document may be the subject of patent rights. CCSDS shall not be held responsible for identifying any or all such patent rights.

Through the process of normal evolution, it is expected that expansion, deletion, or modification of this document may occur. This Recommended Standard is therefore subject to CCSDS document management and change control procedures, which are defined in the *Procedures Manual for the Consultative Committee for Space Data Systems*. Current versions of CCSDS documents are maintained at the CCSDS Web site:

<http://www.ccsds.org/>

Questions relating to the contents or status of this document should be addressed to the CCSDS Secretariat at the address indicated on page i.

At time of publication, the active Member and Observer Agencies of the CCSDS were:

Member Agencies

- Agenzia Spaziale Italiana (ASI)/Italy.
- Canadian Space Agency (CSA)/Canada.
- Centre National d'Etudes Spatiales (CNES)/France.
- China National Space Administration (CNSA)/People's Republic of China.
- Deutsches Zentrum für Luft- und Raumfahrt e.V. (DLR)/Germany.
- European Space Agency (ESA)/Europe.
- Federal Space Agency (FSA)/Russian Federation.
- Instituto Nacional de Pesquisas Espaciais (INPE)/Brazil.
- Japan Aerospace Exploration Agency (JAXA)/Japan.
- National Aeronautics and Space Administration (NASA)/USA.
- UK Space Agency/United Kingdom.

Observer Agencies

- Austrian Space Agency (ASA)/Austria.
- Belgian Federal Science Policy Office (BFSPPO)/Belgium.
- Central Research Institute of Machine Building (TsNIIMash)/Russian Federation.
- China Satellite Launch and Tracking Control General, Beijing Institute of Tracking and Telecommunications Technology (CLTC/BITTT)/China.
- Chinese Academy of Sciences (CAS)/China.
- Chinese Academy of Space Technology (CAST)/China.
- Commonwealth Scientific and Industrial Research Organization (CSIRO)/Australia.
- CSIR Satellite Applications Centre (CSIR)/Republic of South Africa.
- Danish National Space Center (DNSC)/Denmark.
- Departamento de Ciência e Tecnologia Aeroespacial (DCTA)/Brazil.
- European Organization for the Exploitation of Meteorological Satellites (EUMETSAT)/Europe.
- European Telecommunications Satellite Organization (EUTELSAT)/Europe.
- Geo-Informatics and Space Technology Development Agency (GISTDA)/Thailand.
- Hellenic National Space Committee (HNSC)/Greece.
- Indian Space Research Organization (ISRO)/India.
- Institute of Space Research (IKI)/Russian Federation.
- KFKI Research Institute for Particle & Nuclear Physics (KFKI)/Hungary.
- Korea Aerospace Research Institute (KARI)/Korea.
- Ministry of Communications (MOC)/Israel.
- National Institute of Information and Communications Technology (NICT)/Japan.
- National Oceanic and Atmospheric Administration (NOAA)/USA.
- National Space Agency of the Republic of Kazakhstan (NSARK)/Kazakhstan.
- National Space Organization (NSPO)/Chinese Taipei.
- Naval Center for Space Technology (NCST)/USA.
- Scientific and Technological Research Council of Turkey (TUBITAK)/Turkey.
- Space and Upper Atmosphere Research Commission (SUPARCO)/Pakistan.
- Swedish Space Corporation (SSC)/Sweden.

CCSDS RECOMMENDED STANDARD FOR DATA TRANSMISSION AND  
PN RANGING FOR 2 GHz CDMA LINK VIA DATA RELAY SATELLITE

- United States Geological Survey (USGS)/USA.

## DOCUMENT CONTROL

Document	Title	Date	Status
CCSDS 415.1-B-1	Data Transmission and PN Ranging for 2 GHz CDMA Link via Data Relay Satellite, Recommended Standard, Issue 1	September 2011	Current issue
<u>415.1-B-2</u>	<u>Data Transmission and PN Ranging for 2 GHz CDMA Links, Including RELAY and Lunar</u>	<u>April 2023</u>	<u>Add lunar environment and non-regenerative ranging</u>



## CONTENTS

<u>Section</u>	<u>Page</u>
<b>1 INTRODUCTION</b> .....	<b>1-1</b>
1.1 PURPOSE.....	1-1
1.2 SCOPE.....	1-1
1.3 APPLICABILITY .....	1-2
1.4 RATIONALE.....	1-2
1.5 DOCUMENT STRUCTURE .....	1-3
1.6 NOMENCLATURE AND CONVENTIONS .....	1-3
1.7 REFERENCES .....	<a href="#">1-51-4</a>
<b>2 OVERVIEW</b> .....	<b>2-1</b>
2.1 ARCHITECTURE.....	2-1
2.2 SUMMARY OF FUNCTIONS .....	2-3
2.3 PN CODE TYPES.....	2-6
<b>3 SERVICE AVAILABILITY OF PN SPREAD LINKS FOR A COMMUNICATION SYSTEM</b> .....	<b>3-1</b>
3.1 CCSDS PN CODE ASSIGNMENT .....	3-1
3.2 FORWARD AND RETURN DATA SERVICES.....	3-1
3.3 COHERENT RETURN .....	3-1
3.4 VEHICLE TRACKING.....	3-1
3.5 INTEROPERABILITY.....	3-1
3.6 FORWARD .....	3-1
3.7 RETURN .....	3-1
3.8 TIME TRANSFER .....	3-2
<a href="#">3.9 Non-regenerative ranging and communication</a>	
<b>4 FORWARD SERVICE MODE PN SPREAD SIGNAL FORMAT</b> .....	<b>4-1</b>
4.1 GENERAL.....	4-1
4.2 COMMAND CHANNEL (I).....	4-1
4.3 COMMAND LINK SIGNAL PARAMETERS.....	4-1
4.4 COMMAND LINK PN CODE PROPERTIES .....	4-3
4.5 RANGE CHANNEL (Q).....	4-3
4.6 RANGE LINK SIGNAL PARAMETERS .....	4-4
4.7 RANGE LINK PN CODE PROPERTIES.....	4-4
<a href="#">4.8 FORWARD LINK WITH NON-REGENERATIVE RANGING</a> .....	<a href="#">4-4</a>

## CONTENTS (continued)

<u>Section</u>	<u>Page</u>
<b>5 RETURN SERVICE MODE PN SPREAD SIGNAL FORMAT .....</b>	<b>5-1</b>
5.1 GENERAL.....	5-1
5.2 COHERENT MODES .....	5-1
5.3 NON-COHERENT MODE .....	5-4
5.4 <u>NON-REGENERATIVE RANGING.....</u>	<u>5-4</u>
<b>6 NETWORK ELEMENT REQUIREMENTS .....</b>	<b>6-1</b>
6.1 OVERVIEW .....	6-1
6.2 TRANSMIT REQUIREMENTS .....	6-1
6.3 RECEIVE REQUIREMENTS.....	6-1
6.4 PN RANGING CALIBRATION .....	6-1
6.5 PN TIME TRANSFER .....	6-2
<b>7 USER ELEMENT REQUIREMENTS FOR PN SPREADING.....</b>	<b>7-1</b>
7.1 OVERVIEW .....	7-1
7.2 GENERAL.....	7-1
7.3 RECEIVE REQUIREMENTS.....	7-1
7.4 PERFORMANCE REQUIREMENTS .....	7-2
7.5 TRANSMIT REQUIREMENTS .....	7-2
7.6 RANGING PERFORMANCE.....	7-3
7.7 TIME TRANSFER REQUIREMENTS .....	7-4
7.8 PN CODE PERFORMANCE.....	7-5
<b>ANNEX A SECURITY (INFORMATIVE).....</b>	<b>A-1</b>
<b>ANNEX B GLOSSARY (INFORMATIVE) .....</b>	<b>B-1</b>
<b>ANNEX C INFORMATIVE REFERENCES (INFORMATIVE) .....</b>	<b>C-1</b>

### Figure

1-1 Shift Register with Corresponding Characteristic Polynomial .....	1-4
2-1 DSSS System Network Element Architecture .....	2-1
2-2 DSSS System User Element Architecture .....	2-2
4-1 CCSDS Command Link Gold Code Generator .....	4-3
4-2 CCSDS Range Channel Code Generator.....	4-4
5-1 Coherent Return Modes PN Code Generator.....	5-3
5-2 Non-coherent Return Mode CCSDS PN Gold Code Generator .....	5-6
7-1 Time Transfer Interface Timing Diagram.....	7-4

**CONTENTS (continued)**

<u>Table</u>		<u>Page</u>
4-1	Forward I Channel Service Signal Parameters .....	4-2
4-2	Salient Characteristics of PN Codes for Forward Services .....	4-2
4-3	Forward Q Channel PSK Service Signal Parameters .....	4-4
5-1	Coherent Return Service Signal Parameters .....	5-2
5-2	Non-coherent Return Service Signal Parameters.....	5-5



## 1 INTRODUCTION

### 1.1 PURPOSE

The purpose of this Recommended Standard is to specify a set of Code Division Multiple Access (CDMA) Direct Sequence (DS) spread spectrum modulation schemes for CCSDS Users. The schemes described in this Recommended Standard are currently used by NASA, ESA, and JAXA Users but are considered applicable to a wider CCSDS community. These schemes are to be used over space-to-space communications links by space missions and may also be used as Lunar proximity links.

Use of a common set (family) of spreading codes allows for minimum interference among Users and keeps signals from exceeding power spectral density limitations. The schemes described here are from the point of view of a LEO satellite or other satellite below GEO altitude transmitting to a relay satellite at GEO altitude in the 2 GHz frequency band. This section extends this document to the Lunar environment and adds the ability to use the schemes in a non-regenerative (transparent) mode.

The signals can also radiate upon the Earth and be received by an Earth station. Although it is not the intent of this document, an agency may choose to use the direct-to-Earth link. In order to avoid interference between such an operation and the Users of the relay link, the CCSDS recommends that, if any CCSDS member agency chooses such a link, it uses these codes so as to avoid mutual interference.

CDMA spread spectrum modulation has the inherent characteristic that the codes may be used for ranging and time transfer.

The codes in this book are pseudo random and have been specifically chosen to limit the signal Power Spectral Density (PSD) at the Earth's surface and minimize Multiple Access Interference (MAI).

CCSDS recommends that member agencies that require PN ranging via Data Relay Satellite, use the codes described in this book.

### 1.2 SCOPE

This Recommended Standard defines CDMA spread spectrum modulation schemes in terms of:

- a) the services provided to the Users of this specification;
- b) spreading code formats; and
- c) the procedures performed to generate and process the code formats.

It does not specify:

- a) individual implementations or products;

- b) the methods or technologies required to perform the procedures; or
- c) the management activities required to configure and control the system.

This Recommended Standard provides only those parameter requirements relating to signal compatibility with the existing SNIP PN spread modulation systems (reference [\[C1\]\[F4\]](#)). There are many other types of requirements, not specifically related to PN spread modulation signal formats, which must be met to ensure system compatibility with existing SNIP hardware. Examples would include forward error correction coding format, data signal formats, etc.

### 1.3 APPLICABILITY

This Recommended Standard applies to the creation of agency standards and to the future data communications over space links between CCSDS agencies in cross-support situations. This Recommended Standard includes comprehensive specification of the data formats and procedures for inter-agency cross support. It is neither a specification of, nor a design for, real systems that may be implemented for existing or future missions.

The Recommended Standard specified in this document is to be invoked through the normal standards programs of each CCSDS agency, and is applicable to those missions for which cross support based on capabilities described in this Recommended Standard is anticipated. Where mandatory capabilities are clearly indicated in sections of this Recommended Standard, they must be implemented when this document is used as a basis for cross support. Where options are allowed or implied, implementation of these options is subject to specific bilateral cross-support agreements between the agencies involved.

### 1.4 RATIONALE

There is a Space Network Interoperability Panel (SNIP) agreement between three of the CCSDS agencies, NASA, ESA, and JAXA, that use a family of CDMA codes referred to as the SNIP code family. Recently, other CCSDS space agencies have shown interest in using similar CDMA techniques. If these agencies used PN spreading codes that were not compatible with the existing codes, interference and degraded service would be more likely to occur with both Users of the existing codes and Users of the new codes. The SNIP code family is limited in number and not sufficient for all of the CCSDS agencies that would like to participate. In order to promote interoperability and broaden the available set of codes agencies are permitted to use, CCSDS has developed a new family of codes presented here, referred to as the CCSDS PN code family, that have the same properties as the codes used by the SNIP agencies.

The CCSDS believes it is important to document the rationale underlying the recommendations chosen, so that future evaluations of proposed changes or improvements will not lose sight of previous decisions.

## 1.5 DOCUMENT STRUCTURE

This document is divided into seven numbered sections and three annexes:

- a) section 1 presents the purpose, scope, applicability, rationale and structure of this Recommended Standard and lists the conventions used throughout the document;
- b) section 2 provides an overview of PN code usage for CDMA spread spectrum links;
- c) section 3 provides requirements that are applicable on a system level for managing CCSDS Spread Spectrum modulation;
- d) section 4 specifies forward service mode PN spread signal formats (network-to-User);
- e) section 5 specifies return service mode PN spread signal formats (User-to-network);
- f) section 6 specifies PN code requirements relating to network elements;
- g) section 7 specifies functional and performance requirements for User element equipment in a system employing CCSDS PN Spread modulation formats relating to compatible CCSDS transponder/transceiver;
- h) annex A contains link security information;
- i) annex B is a glossary of abbreviations and terms used in the document;
- j) annex C provides informative references.

## 1.6 NOMENCLATURE AND CONVENTIONS

### 1.6.1 NOMENCLATURE

#### 1.6.1.1 Terms Used in Normative Statements

The following conventions apply throughout this Recommended Standard:

- a) the words ‘shall’ and ‘must’ imply a binding and verifiable specification;
- b) the word ‘should’ implies an optional, but desirable, specification;
- c) the word ‘may’ implies an optional specification;
- d) the words ‘is’, ‘are’, and ‘will’ imply statements of fact.

#### 1.6.1.2 Terminology Used for Code Groupings

Type	Maximal vs. Gold
Family	distinguish SNIP and CCSDS PN code sets
Set	User group of PN codes (forward, return, coherent, non-coherent)

Library list of all codes used to make code sets for Users

## 1.6.2 CONVENTIONS

PN codes are generated by simple linear shift register circuits, called Linear Feedback Shift Register (LFSR). The values in the tapped stages are combined using modulo-2 addition and the results are fed back to the first stage of the register on the next shift. The feedback tap configuration of an  $N$ -stage shift register is defined by a characteristic polynomial of order  $N$ . An example of a characteristic polynomial and its corresponding shift register is shown below in figure 1-14-1. The maximum length pattern that can be generated with an  $N$ -stage shift register is  $L = 2^N - 1$ .

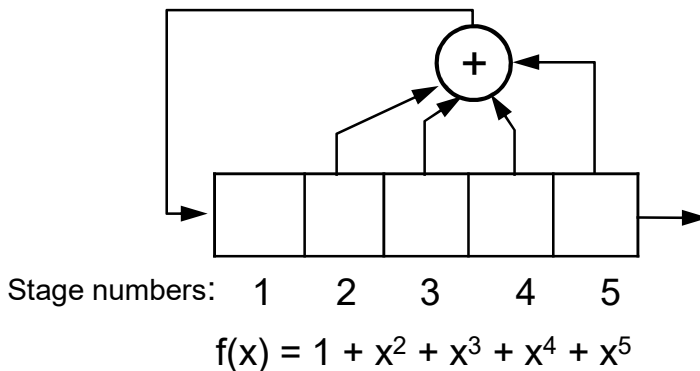

**Figure 1-1: Shift Register with Corresponding Characteristic Polynomial**

The notation used in this Recommended Standard follows the above diagram. The feedback tap locations correspond to the exponents of  $x$  with non-zero polynomial coefficients. In the example polynomial above,  $f(x) = 1 + x^2 + x^3 + x^4 + x^5$ , the feedback taps are on the second, third, fourth, and fifth stage of the five stage shift register. The first stage has no feedback tap and corresponds to the zero valued coefficient of  $x^1$ . The leading '1' in the polynomial represents  $x^0$ , which is the feedback input to the first stage of the shift register. The output of the register is from the fifth stage.

Some key points to note about LFSRs and the characteristic polynomial used to describe them are:

- The length of the shift register (i.e., the number of stages) equals the order of the polynomial.
- The highest order term of the polynomial is the last stage of the shift register and is always used in the shift register feedback path.
- The feedback tap represents the '1' ( $x^0$ ) term in the polynomial.



## **1.7 REFERENCES**

This Recommended Standard contains no normative references. Informative references are contained in annex C.



## 2 OVERVIEW

### 2.1 ARCHITECTURE

Figures [2-12-1](#) and [2-22-2](#) contain block diagrams of the Network and User elements in a Direct Sequence Spread Spectrum (DSSS) RF communications system.

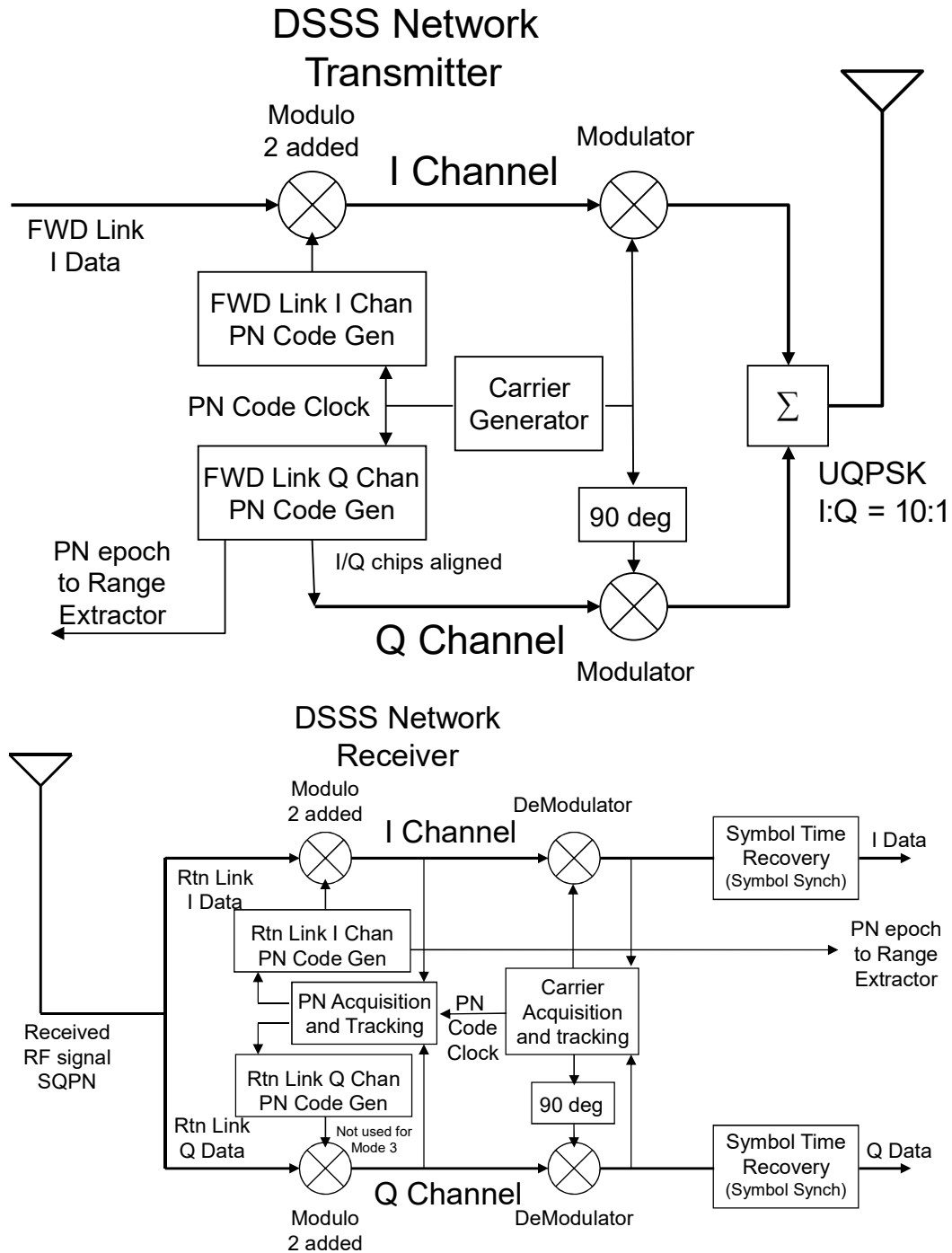

Figure 2-1: DSSS System Network Element Architecture

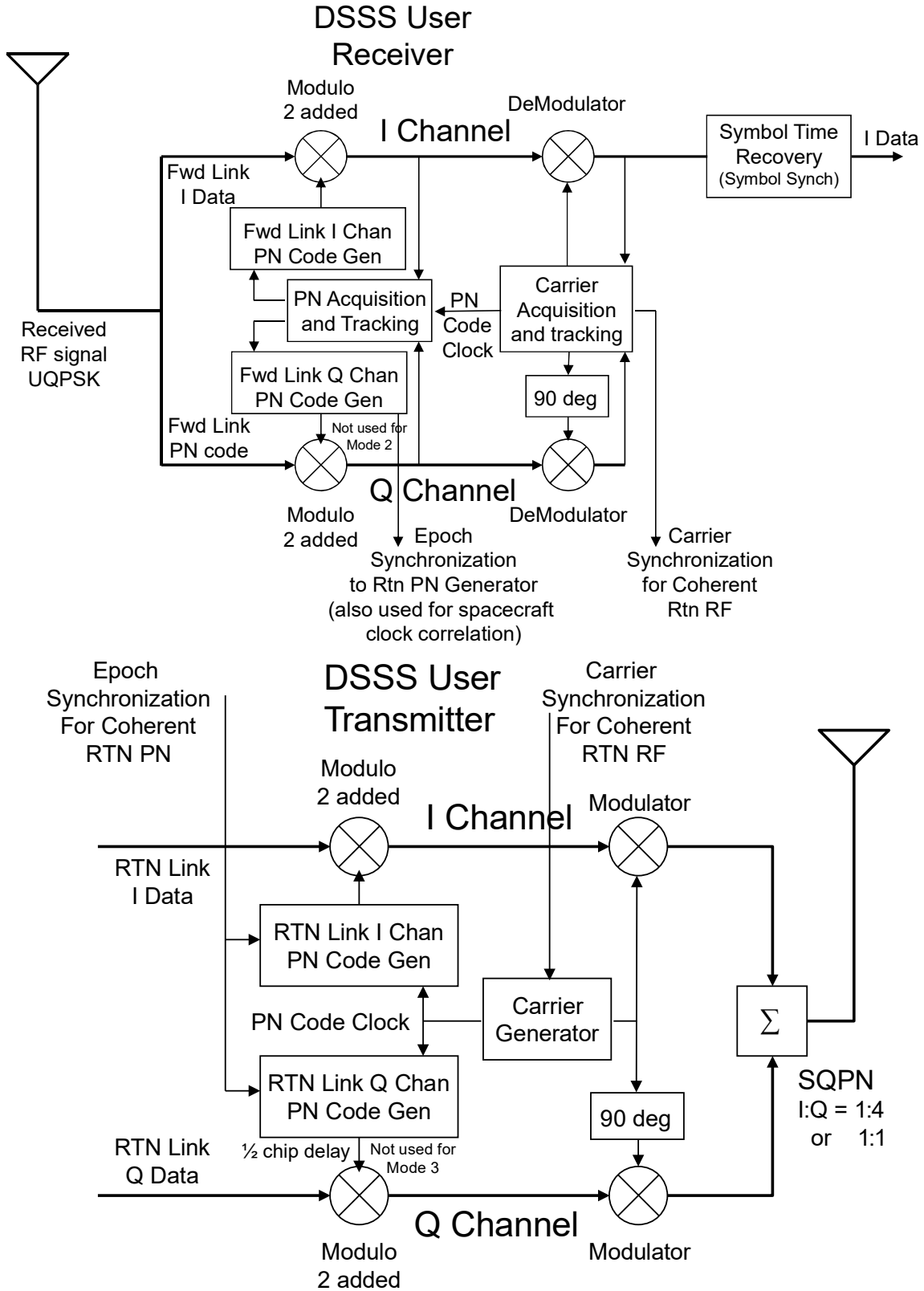

Figure 2-2: DSSS System User Element Architecture

The network element transmits forward service data to the User element and the User element transmits return service data back to the network. In these figures, a QPSK type modulation format is used to transmit the PN spread signals. The forward modulation format is referred to as Quadrature PN (QPN) modulation, and on the return link it is referred to as Staggered Quadrature PN (SQPN) modulation since the QPSK chips are staggered (see 7.8.2). However, in order to improve the command signal, a BPSK modulation format could also be used to transmit the forward PN spread data when RF and PN coherency is not required. When a spread spectrum BPSK modulation is used, the Q channel sections in figures [2-12-1](#) and [2-22-2](#) do not exist.

In both the network and the User transmitters, data bits (or coded data symbols) are placed into I and Q channels which are spread separately by modulo-2, asynchronously, adding the symbols to PN sequences. In these figures, distinct pattern PN sequences are used on the return signals for the non-coherent case and pattern-shifted PN sequences (same pattern, different phase) are used on the I and Q return channels for the coherent case. The particular choice of how the Q channel pattern is shifted relative to the I channel pattern is not a requirement for DSSS, but it does represent this recommendation.

Spread symbol sequences are input to BPSK modulators on each channel, and the outputs of these are combined to produce the QPN or SQPN signal. At the receiver side, carrier acquisition, PN acquisition, de-spreading, and symbol timing recovery are depicted as separate operations, although they may be performed in parallel. Since acquisition requires both PN correlation and carrier correlation, sweeping the forward link would not guarantee that both will be achieved simultaneously. Therefore the network element performs Doppler pre-compensation for the PN code chip rate and carrier.

PN acquisition is accomplished by adjusting a correlator until the timing offset between the reference PN sequence generated internally and the PN sequence in the received signal are aligned. When this occurs, the received signal is de-spread.

The transmit User element in figure [2-22-2](#) is configured to synchronize the epoch of the return signal spreading sequences with the received forward signal epoch. This facilitates the ranging measurement depicted in figure [2-12-1](#).

## 2.2 SUMMARY OF FUNCTIONS

### 2.2.1 OVERVIEW

The Network Transmitter accepts spacecraft command symbols from the MOC; PN spreads them and modulates them on the I, command channel. A second, Q channel (range channel), contains the Ranging PN code but no data symbols, and the two are combined into a QPSK channel with unequal power, UQPSK. The ranging PN code is also available for the User Spacecraft Clock Calibration System (USCCS) time transfer service.

The User Receiver de-spreads and demodulates the command symbols and, if used, correlates its internal PN generator to the received ranging PN code. When the ranging service is used,

the ranging code phase information is passed to the User transmitter, and, when the time transfer service is also used, a pulse is output to the User spacecraft.

The chip rates considered in this standard are designed to be coherent with the carrier. The rates are approximately 3 Mc/s. The User Transmitter spreads both the I and Q channel for channel symbol rates at and under 300 ks/s and modulates them in an SQPN format. When the ranging service is used, the return I channel PN code is in phase with the received Q channel PN code.

The Network Receiver de-spreads and demodulates the I and Q channel symbols and outputs PN range code phase information which, when combined with the Network Transmitter range code phase, results in spacecraft range data. The network receiver also generates messages required for the time transfer function.

This document also covers transparent ranging but only in selected sections.

For transparent PN ranging, the uplink process can be exactly the same as in the regenerative ranging case. However, in transparent PN ranging the spacecraft does not attempt to correlate the ranging pattern; instead, it modulates the uplink ranging signal as received on board onto the downlink without further processing. The ground station receiver demodulates the downlink and performs the PN ranging correlation in the same manner as for regenerative ranging. Because any uplink noise is re-modulated onto the downlink, transparent ranging accuracy will generally not be as good as with regenerative ranging; however, transparent ranging requires less complexity in the spacecraft transponder.

## 2.2.2 GENERAL

DSSS provides the following functions over a space link:

- a) multiple simultaneous Users;
- b) reduced power spectral density (PSD);
- c) reduction in interference susceptibility (including jamming and multipath); and
- d) capability of supporting PN ranging and time transfer operations.

## 2.2.3 MULTIPLE SIMULTANEOUS USERS

One of the key applications for CDMA systems is to allow multiple Users to utilize the same frequency band simultaneously to transmit PN spread signals. The composite RF signal in this band then is the sum of the multiple RF DSSS signals plus any noise or external interference. Each of the Users is assigned a unique set of PN spreading sequences.

The properties of CDMA are such that when a signal is spread using one sequence, de-spreading with another sequence leaves the unwanted signal in a spread state. This allows

receivers operating on the composite signal to pull out the signal corresponding to their assigned PN sequence.

After de-spreading, the composite PSD consists of the desired signal narrowband high power component plus the wideband, low power contributions from the other Users' signals (MAI) and noise. Since the wideband low power PSD contributions from other Users are mostly flat over the narrow desired signal frequency band, they are often described as 'noise-like' interference, and the effect of adding more Users is characterized as 'increasing the noise floor'.

#### **2.2.4 REDUCED PSD**

The PSD of a spread signal is greatly reduced compared to that of an unspread signal, by a factor of the PN rate to the symbol rate. Because of emission spectra restrictions on the Earth's surface, this is advantageous when a relay satellite is used and the forward signal is being transmitted in the direction of the Earth instead of away from the Earth. Since the return link to a GEO relay satellite, in terms of power emission, significantly exceeds the direct-to-Earth link, the reduced PSD of PN spreading is again advantageous.

#### **2.2.5 REDUCTION IN INTERFERENCE SUSCEPTIBILITY**

DSSS is used to reduce susceptibility to RF interference, whether that interference is accidental or the result of deliberate jamming efforts. In the receiver, the entire composite signal (noise, intended signal, and interferer) is modulo-2 added to the high rate PN sequence. This has three effects. First, it re-constitutes the original high power spectral density narrowband desired signal. Second, it causes other spread signals to remain spread and appear noise like. Third, it spreads the power in narrowband interfering signal over the wider PN sequence bandwidth just as is done in the DSSS transmitter.

#### **2.2.6 SUPPORT OF PN RANGING OPERATIONS**

In a system where RF links between two elements employ PN spread modulation formats, the spreading code can be used for range measurements. The mechanism by which this is accomplished is similar to that described in the CCSDS PN Ranging Book (reference [C2][E2]) and described in the series of steps below (the codes in reference [C2][E2] are not appropriate for CDMA and hence are not appropriate for a near-Earth relay satellite):

- a) The element functioning as the network generates a PN sequence, uses this sequence to spread forward link symbols, and transmits the signal to the User element.
- b) The User element (generally a transponder or transceiver) generates the same PN sequence and uses it to de-spread the forward link symbols. In order to do this, it aligns in time (correlates) its internally generated sequence with that of the received signal.

- c) The User element then generates a second PN sequence (to spread the return link symbols) aligns the epoch of this sequence with that of the received signal, spreads the return link symbols, and transmits the resulting spread signal to the first element (network). This is called regenerative PN. Transparent PN, where the PN code is retransmitted without being regenerated, is not considered in this Recommended Standard.
- d) The network element receives the return link signal, generates a matching PN code, aligns it to the received signal, and de-spreads the return link symbols.
- e) The time offset between the transmitted forward link PN sequence and the received return link PN sequence is a measure of the unambiguous portion of the total round-trip delay time. By removing the processing time delays, adding the number of known PN periods, and multiplying by the speed of light, a measure of the (round-trip) range is obtained.

### 2.3 PN CODE TYPES

There are two types of PN codes used in the recommended Spread Spectrum systems, Maximal Length codes and Gold Codes. All of the codes of a particular type are generated from a single circuit or a related set of circuits. Circuits to generate Maximal Length PN Codes differ only in the feedback taps of the circuit. Circuits to generate PN codes belonging to the class of Gold codes differ only in the initial conditions of the shift registers. The same code types are currently used in the SNIP agreement for a number of services and are recommended for CCSDS Users as follows:

- Gold Codes:
  - Forward Command Channel (I Channel).
  - Return (I and Q Channels) when tracking and coherent PN based time transfer is not required (DG1 Mode 2).
- Maximal Length Codes:
  - Forward Range Channel (Q Channel).
  - Return (I and Q Channels) when tracking or PN based time transfer is required and the symbol rate is equal to or below 300 ks/s (DG1 Mode 1).
  - Return (I Channel) when tracking or PN based time transfer is required, the symbol rate on the I channel is less than or equal to 300 ks/s, and the symbol rate on the Q Channel is above 300 ks/s (DG1 Mode 3).

Each User is assigned a set of PN codes to cover all of the communication links: forward, coherent return, and non-coherent return. The collection of these sets of codes is referred to as a PN code library. Each of these types contains a finite number of codes. The CCSDS



CCSDS RECOMMENDED STANDARD FOR DATA TRANSMISSION AND  
PN RANGING FOR 2 GHz CDMA LINK VIA DATA RELAY SATELLITE

library is generated similar to the SNIP library in order to allow for interoperability between agencies without mutual interference.

The PN code libraries for general Users in the CCSDS community are maintained by the CCSDS Secretariat and distributed by SFCG.



### **3 SERVICE AVAILABILITY OF PN SPREAD LINKS FOR A COMMUNICATION SYSTEM**

NOTE – This section provides requirements that are applicable on a system level for links using Spread Spectrum modulation.

#### **3.1 CCSDS PN CODE ASSIGNMENT**

The CDMA system shall support CCSDS PN code assignments to specific platforms as assigned by the SFCG.

#### **3.2 FORWARD AND RETURN DATA SERVICES**

The CDMA system shall support CCSDS PN spread modulation on both the forward and return data transfer services.

#### **3.3 COHERENT RETURN**

The User element shall be capable of supporting a coherent RF and PN turnaround mode of operation if PN ranging, Doppler tracking, or PN time transfer is required.

#### **3.4 VEHICLE TRACKING**

The Network element shall support tracking services by reporting range and Doppler information when the User vehicle is in Coherent Mode and those services are required.

NOTE – The format for the reporting is subject to agreement by the implementing parties and is not addressed in this Recommended Standard. An example format specification is reference [\[C4\]](#)~~[C4]~~.

#### **3.5 INTEROPERABILITY**

These services shall be compatible with the existing SNIP system PN spread modes.

#### **3.6 FORWARD**

Systems using PN spread modulations on forward links shall comply with the requirements specified in section 4.

#### **3.7 RETURN**

Systems using PN spread modulations on the return service shall comply with requirements specified in section 5.

### **3.8 TIME TRANSFER**

Systems using the Time Transfer service to calibrate their spacecraft clock shall comply with requirements specified in 6.5 and 7.7.

### **3.9 NON-REGENERATIVE RANGING AND COMMUNICATION**

Ranging and communicating without the need for the User transponder to correlate the PN pattern or despread the data is specified in several sections with the major information in sections 4.8 and 5.4.

## **4 FORWARD SERVICE MODE PN SPREAD SIGNAL FORMAT**

### **4.1 GENERAL**

**4.1.1** CCSDS forward link services using spread spectrum shall meet the requirements specified below.

NOTE – These subsections detail the signal format requirements applicable to the Command and Range channels respectively. CCSDS utilizes I channel for command data and Q channel for range service.

**4.1.2** The I/Q channel power ratio shall be 10 dB; i.e., the Q channel power shall be 10 dB below the I channel power (UQPSK modulation format).

### **4.2 COMMAND CHANNEL (I)**

The PN code signal parameter requirements for the forward command channel shall be as described in 4.3. The method of generating these CCSDS PN codes shall be as described in 4.4.

### **4.3 COMMAND LINK SIGNAL PARAMETERS**

**4.3.1** I (Command) channel shall include a short PN code and contain the forward service data.

**4.3.2** PN Forward I channel shall meet the signal requirements specified in table [4-14-1](#).

**4.3.3** In addition, Forward I channel shall meet the PN Code chip requirements specified in table [4-24-2](#).

**Table 4-1: Forward I Channel Service Signal Parameters**

Parameter	Requirements
Transmit carrier frequency (Hz)	$F_{Fwd}$
Command Channel, UQPSK or BPSK (note 1)	
PN code modulation and stagger	Phase Shift Key (UQPSK, I and Q chips aligned),
Carrier suppression	30 dB minimum
PN code length (chips)	$2^{10} - 1$
PN code epoch reference	User unique initial condition
PN code family	Gold codes
PN code chip rate (chips/s)	$\frac{31}{221 \times 96} \times F_{Fwd}$
Data modulation	Modulo-2 added asynchronously to PN code
Symbol rate restrictions (note 2)	0.1 - 300 ks/s
NOTES	
1	In case of SS-BPSK mode, the I channel specification is applicable to BPSK.
2	The forward symbol rate in this table is the symbol rate that will be transmitted by the Network element (includes all coding and symbol formatting but excludes the spread spectrum chipping). Forward data conditioning is transparent to the Network element. These transparent operations should be performed by the User control center prior to transmission to the Network element data interface.
3	The frequency received by the User, $F_{recv}$ , will be slightly different from $F_{Fwd}$ because of Doppler.

**Table 4-2: Salient Characteristics of PN Codes for Forward Services**

Parameter	Requirements
PN chip jitter (rms) (including effects of Doppler compensation)	$\leq 1$ degree
Command/range channel PN chip skew deviation (peak)	$\leq 0.01$ chip
PN chip asymmetry (peak)	$\leq 0.01$
PN chip rate error (peak) relative to absolute coherence with carrier rate	$\leq 0.01$ chips/s at PN code chip rate

#### 4.4 COMMAND LINK PN CODE PROPERTIES

4.4.1 The command link circuit shall use two single-shift registers of length 10.

4.4.2 The feedback taps shall be the same for each agency and the codes shall differ only in the initial conditions of Register A.

4.4.3 The set of Gold codes corresponding to this circuit hold the following properties:

- a) a total of  $2^{10} = 1024$  sequences (codes) can be generated by altering the initial conditions of only one of the shift registers;
- b) each code is  $2^{10} - 1 = 1023$  symbols long;
- c) of the 1024 codes, 768 are balanced codes; i.e., each code has precisely 512 ones and 511 zeros.

4.4.4 Figure 4-14-1 provides the Gold code generator circuit that shall be used in the Forward Command Link.

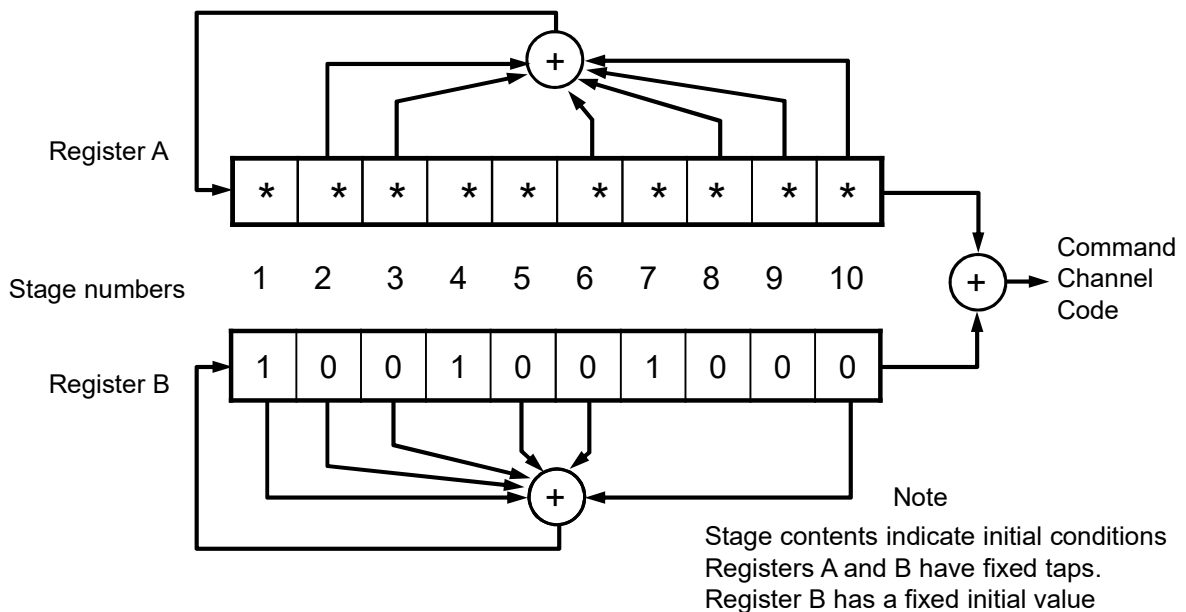

**Figure 4-1: CCSDS Command Link Gold Code Generator**

#### 4.5 RANGE CHANNEL (Q)

The PN code signal parameter requirements for the forward range channel shall be as described in 4.6. The method of generating these CCSDS PN codes shall be as described in 4.7.

#### 4.6 RANGE LINK SIGNAL PARAMETERS

4.6.1 Forward Q channel (range channel) shall meet the requirements specified in table [4-24-2](#).

4.6.2 Forward Q channel shall also meet requirements specified in table [4-34-3](#).

**Table 4-3: Forward Q Channel PSK Service Signal Parameters**

Parameter	Requirements
Transmit carrier frequency (Hz)	$F_{Fwd}$
UQPSK Range Channel	
PN code modulation and stagger	Phase Shift Keying (UQPSK, I and Q chips aligned)
Carrier suppression	30 dB minimum
PN code chip rate	Synchronized to same rate as command channel PN code chip rate
PN code length	$(2^{10} - 1) \times 256$
PN code epoch reference	All '1's condition synchronized to the command channel PN code epoch
PN code family	Truncated 18-stage shift register sequences

#### 4.7 RANGE LINK PN CODE PROPERTIES

4.7.1 The 18-stage register circuit shown in figure [4-24-2](#) shall be used to generate the CCSDS Range Channel Codes.

4.7.2 CCSDS ranging codes shall have between 8 and 12 tap connections.

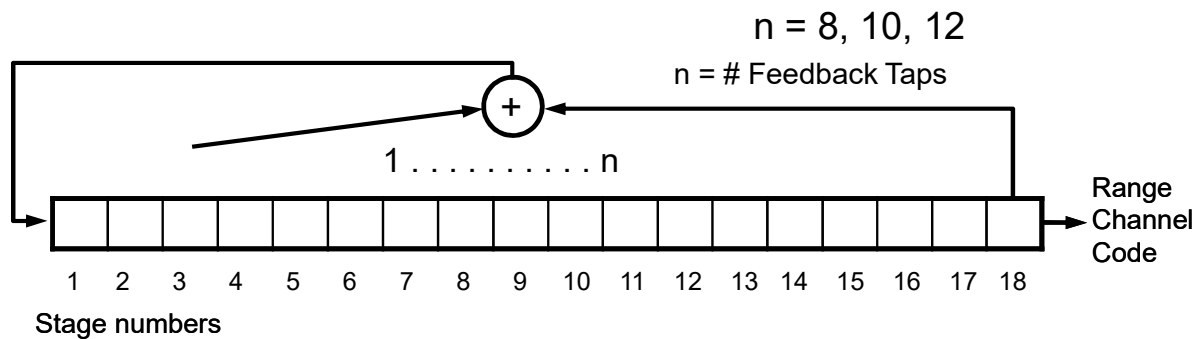

**Figure 4-2: CCSDS Range Channel Code Generator**



NOTE – The initial conditions for the Ranging Code circuit depicted above are the same for each code. The codes differ in their unique feedback tap assignments. Libraries of codes were selected from the set having the following properties:

- a) Codes are of length  $2^{18} - 1 = 262143$ .
- b) Codes are truncated to an integer multiple (256) of the command code length,  $(2^{10} - 1) * 256 = 261888$ . The all '1's initial condition of the register is synchronized to the 1001001000 state of the B register of the Command Channel Code generator as shown in figure ~~4-14-1~~. Thus, the last  $262143 - 261888 = 255$  bits of the code are not generated before the shift register is reset to its initial all '1's condition. This synchronization and truncation process permits rapid acquisition of the longer code using the short code.
- c) 1898 maximal length codes have been identified for use as Range Channel code with 8, 10, or 12 taps.

#### **4.8 FORWARD LINK WITH NON-REGENERATIVE RANGING**

When a project wants to avoid the need to correlate and re-generate the PN ranging pattern in the User transponder, a non-regenerative scheme may be used.

With non-regenerative ranging, Figures 2-1 and 2-2 no longer apply in all of their detail. The de-spreading may not be used depending on the option chosen and generation of the return link patterns shall not be done.

Sections and figures that show the generation of the forward range patterns shall still apply.

Sections and figures that show the command spreading shall apply if an option requiring command spreading is used.

The patterns for non-coherent PN patterns shall not be used.

There are several options. The configuration of the return link will depend on which forward link option is chosen.

1. The forward link as previously describe for re-generative ranging can be used.
  - a. The User would still need to correlate and de-spread the command data.
  - b. The User would not correlate the range channel, but would use it for the return link.
2. A modified forward link where the command data is not spread, and the power ratio is 1:1.
3. A forward link where there is only a ranging pattern, BPSK modulated on the carrier.

CCSDS RECOMMENDED STANDARD FOR DATA TRANSMISSION AND  
PN RANGING FOR 2 GHz CDMA LINK VIA DATA RELAY SATELLITE

All of these options still allow for CDMA since they all include the PN 18 range pattern, and many patterns are available to CCSDS agencies that have good cross correlation properties.

---

## 5 RETURN SERVICE MODE PN SPREAD SIGNAL FORMAT

### 5.1 GENERAL

CCSDS Return link services using spread spectrum shall meet the requirements specified below.

NOTE – These subsections detail the signal format requirements applicable to the Coherent and Non-coherent modes, respectively.

### 5.2 COHERENT MODES

#### 5.2.1 GENERAL

**5.2.1.1** PN spread symbols (DG1) with RF and PN coherent turnaround (mode 1) shall be used when range and two-way Doppler measurements (coherent transponder operations) are required concurrently with return service data rates at or below 300 ks/s.

**5.2.1.2** For DG1 mode 1 operation, the I and Q channel PN codes shall be identical but offset by at least 20,000 chips (figure [5-15-1](#)).

NOTE – This separation is adequate to identify each data channel unambiguously without requiring a unique PN code for each channel. SS-BPSK is also a possible modulation for DG1 Mode 1.

**5.2.1.3** DG1 Mode 3 shall be used when range and two-way Doppler measurements (coherent transponder operations) are required concurrently with a return service data rate above 300 ks/s.

**5.2.1.4** Restrictions on DG1 mode 3 signal acquisition are identical to those for DG1 mode 1.

**5.2.1.5** In DG1 mode 3, the Q channel must contain only data and no PN code.

#### NOTES

- 1 Multiple Access services are unavailable for DG1 Mode 3.
- 2 There is no channel ambiguity in this mode since I vs Q channel resolution is achieved by using PN correlation in addition to knowledge of I/Q power ratio.

#### 5.2.2 SIGNAL PARAMETERS

Coherent Return services shall meet signal parameters relating to spread spectrum modulation provided in table [5-15-1](#).

**Table 5-1: Coherent Return Service Signal Parameters**

Parameter (note 1)	Definition
Transmit carrier frequency (Hz)	$F_{Rtn}$ Return freq at the User transmitter
Carrier ( $F_{Rtn}$ ) reference (Hz) DG1 mode 1 and 3	$F_{Rtn} = \frac{240}{221} \times F_{recv}$ (Note 3)
PN code modulation DG1 mode 1	SQPN, SS-BPSK
DG1 mode 3, I channel	SS-BPSK I-channel return coherent with Q channel forward
DG1 mode 3, Q channel	BPSK unspread
I/Q power ratio	1:4 or 1:1
PN code chip rate (chips/s)	$\frac{31}{240 \times 96} \times F_{Rtn}$
PN code length (chips) DG1 modes 1 and 3	$(2^{10} - 1) \times 256$
PN code epoch reference DG1 mode 1 I channel	Epoch (all '1's condition) synchronized to epoch (all '1's condition) of received forward service Q (range) channel PN code
Q channel (note 2)	Epoch delayed $x + 1/2$ PN code chips relative to I channel PN code epoch
DG1 mode 3 I channel	Epoch (all '1's condition) synchronized to epoch (all '1's condition) of received forward service Q (range) channel PN code
PN code family DG1 mode 1	Truncated 18-stage shift register sequences
Data modulation: DG1 mode 1	Modulo-2 added asynchronously to PN code
DG1 mode 3: I channel	Modulo-2 added asynchronously to PN code
Q channel	BPSK
Symbol rate restrictions DG1 mode 1	0.1 to 300 ks/s,
DG1 mode 3 I channel	0.1 to 300 ks/s
Chip stagger	Q channel delayed $x+1/2$ PN chip relative to I channel (Note 2)
Chip skew	$\leq 0.01$ chip
PN power suppression	$< 0.3$ dB

Parameter (note 1)	Definition
NOTES	
1	CCSDS transponder/transceiver data configurations, including specific data rate restrictions for coding and formatting, are defined in reference 1 for return services (refer also to Appendix B of reference [C1]).
2	The Q channel PN code sequence is identical to the I channel PN code sequence; but, offset $x + 1/2$ PN chips, where $x > 20,000$ (to avoid channel ambiguity). The value of $x$ is defined by the PN code assignment for a particular CCSDS transponder/transceiver. Offsetting Q channel PN sequence by $1/2$ chip achieves SQPN modulation to prevent simultaneous transitions of the I and Q PN sequences. For data configurations that use two PN spread channels, SQPN modulation is used.
3	$F_{\text{recv}}$ is the received forward frequency $F_{\text{Fwd}}$ plus a Doppler component.

### 5.2.3 COHERENT RETURN PN CODE PROPERTIES

5.2.3.1 Figure 5-15-1 shows the circuit that shall be used to generate the Maximal Length Codes for the CCSDS Return Mode 1 and Mode 3 Links.

5.2.3.2 CCSDS codes shall have between 10 and 12 tap connections.

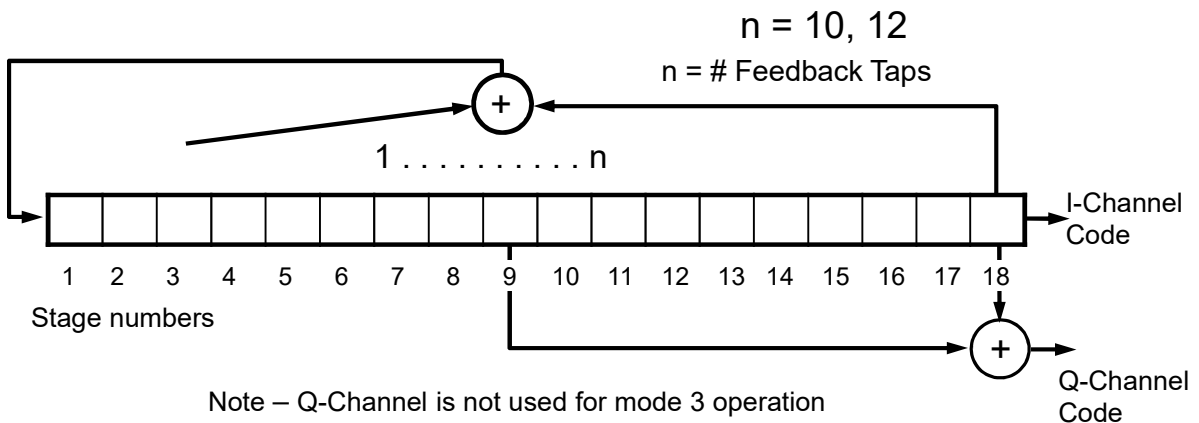

**Figure 5-1: Coherent Return Modes PN Code Generator**

NOTE – The above circuit is an eighteen-stage linear shift register utilized for the Return coherent modes (Modes 1 and 3) Link Codes. Mode 1 uses both the I and the Q Channels, while Mode 3 uses only the I-Channel code. The Q-Channel code is generated by modulo-2 summing the ninth and eighteenth stages, as shown in the figure above. The assigned codes differ in their unique feedback tap assignments. The maximum number of feedback taps is twelve. The initial conditions are the same for each code, an all '1's condition. Libraries of codes were selected from the set having the following properties:

- a) Codes are of length  $2^{18} - 1 = 262143$ .
- b) Codes are truncated to 261888 to synchronize the shift register with the Forward Range channel. Thus, the last  $262143 - 261888 = 255$  bits of the code

are not generated before the shift register is reset to its initial all '1's condition.

- c) A total of 3128 codes have been identified for use as coherent return codes with 10 or 12 taps.

### **5.3 NON-COHERENT MODE**

#### **5.3.1 GENERAL**

**5.3.1.1** Spread (DG1) but non-coherent (mode 2) symbols shall be used when return service signal acquisition is necessary without the requirement for prior CCSDS transponder/transceiver signal acquisition of the forward service (non-coherent transponder/transceiver operation).

**5.3.1.2** For DG1 mode 2, the I and Q channel PN codes shall be unique 11-stage Gold Codes.

NOTE – There is no channel ambiguity in this mode since the PN codes on I and Q channels are different. SS-BPSK is also a possible modulation for DG1 Mode 2.

#### **5.3.2 SIGNAL PARAMETERS**

Non-coherent Return services shall meet signal parameters relating to spread spectrum modulation provided in table [5-25-2](#).

**Table 5-2: Non-coherent Return Service Signal Parameters**

Parameter (note)	Definition
Transmit carrier frequency (Hz)	$F_{Rtn}$ CCSDS transponder/transceiver transmitter oscillator
PN code modulation	SQPN, SS-BPSK
PN code chip rate (chips/s)	$\frac{31}{240 \times 96} \times F_{Rtn}$ (Note 1)
PN code length (chips)	$2^{11} - 1$
PN code epoch reference	Not Applicable
PN code family	Gold codes
Data modulation:	Modulo-2 added asynchronously to PN code
Symbol rate restrictions	2 to 300 ks/s
Chip stagger	Q channel delayed $\frac{1}{2}$ PN chip relative to I channel
Chip skew	$\leq 0.01$ chip
PN power suppression	$< 0.3$ dB

Note 1:  $F_{Rtn}$  is generated by the internal spacecraft oscillator.

### 5.3.3 NON-COHERENT RETURN PN CODE PROPERTIES

5.3.3.1 Figure 5-25-2 shows the Gold code generator that shall be used for the Return non-coherent (Mode 2) link.

5.3.3.2 This circuit shall be composed of three single-shift registers of length 11.

5.3.3.3 The feedback taps shall be the same for all CCSDS Users and the codes shall differ only in the initial conditions of Registers A and C for each User.

5.3.3.4 The set of Gold Codes associated with this circuit has the following properties:

- a) there are  $2^{11} = 2048$  codes generated by altering the stage contents of one of the two shift registers (register A for the I channel codes and register C for the Q channel codes);
- b) each code is  $2^{11} - 1 = 2047$  symbols long;
- c) of the 2048 codes, there are 1022 available balanced codes and 511 I-Q code pairs in the set.

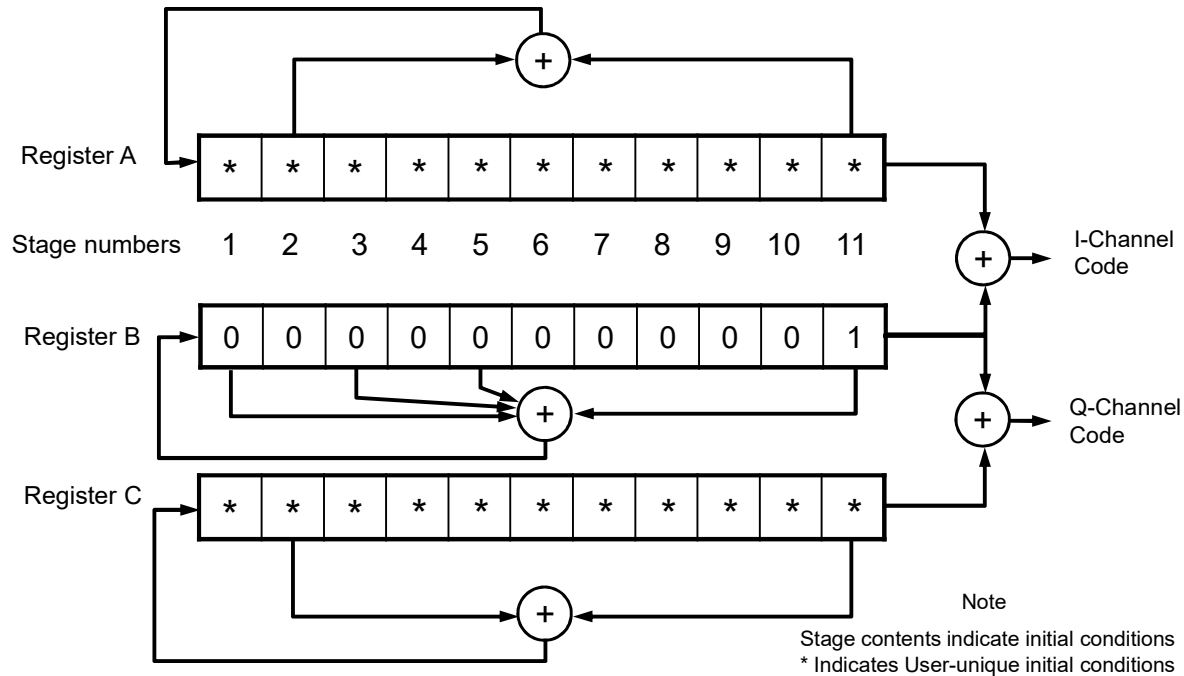

**Figure 5-2: Non-coherent Return Mode CCSDS PN Gold Code Generator**

#### 5.4 NON-REGENERATIVE RANGING

The three options on the forward link lead to 3 options on the return link.

In all cases for the non-regenerative ranging, the forward ranging pattern is use for the return PN pattern. This is in contrast with the regenerative case where a different PN pattern of the same length is used on the return link.

Non-coherent forward to return PN shall not be used for non-regenerative ranging. In previous sections, non-coherent PN is allowed but only for spread spectrum data when ranging is not performed.

In all cases, the link shall be RF coherent. Doppler tracking is an important part of radiometric tracking.

The user transponder shall meet the turnaround delay requirements stated in section 7 for modes 1 and 3.

1. The forward link is as previously describe for re-generative ranging. The return link may or may not have telemetry data. These options shall be managed parameters.

a). when the link is sufficiently strong with an acceptable SNR, the forward ranging pattern can be used on a BPSK return link to spread the telemetry



data. BPSK modulation is suggested since the non-regenerated pattern will have more errors than the regenerative case, limiting the telemetry data rate and thus there will be no need for (O)QPSK.

b) similar to a) but with (O)QPSK modulation where the telemetry is modulated un-spread on the I channel, and the range pattern is on the Q channel.

c) for a less robust link, the forward PN pattern may be modulated as a BPSK return link. This of course would not allow for telemetry data.

2. When using a modified forward link where the command data is not spread, and the power ratio is 1:1, the return channel shall have 2 options

a) (O)QPSK modulation with telemetry data on the I channel and the forward range pattern modulated on the Q channel.

b) the forward range pattern BPSK modulated on the return carrier. In this case there will be no telemetry data.

3. When only a PN range pattern BPSK modulated on a non-regenerative forward link is used, on the forward link, the transponder shall re-modulate that pattern on the return link



## **6 NETWORK ELEMENT REQUIREMENTS**

### **6.1 OVERVIEW**

This section provides requirements relating to network elements. Subsections 6.2 and 6.3 state requirements on transmit and receive functions of the PN spread links. Subsection 6.4 states requirements for PN ranging.

For optimum acquisition performance on the forward links, some User element equipment requires that there shall be no symbol transitions during the signal acquisition process and that there shall be Doppler pre-compensation for PN code chip rate and carrier.

### **6.2 TRANSMIT REQUIREMENTS**

**6.2.1** The network element transmitter shall be capable of generating PN codes in accordance with section 4.

**6.2.2** The network element shall be capable of spreading forward link symbols as described in section 4.

### **6.3 RECEIVE REQUIREMENTS**

**6.3.1** The network element shall be capable of receiving the return link signal using the formats described in section 5.

**6.3.2** The network element shall perform PN acquisition to obtain the epoch of the received code.

**6.3.3** The Network element shall be capable of supporting Users employing any of the PN code sets described in the PN code library.

### **6.4 PN RANGING CALIBRATION**

**6.4.1** If the system employs PN ranging, the network element shall be capable of measuring the delay between the transmitted range code and the received range code.

NOTE – The accuracy of the measurement is subject to agreement by the implementing parties.

**6.4.2** If the system employs PN ranging, the network element shall be capable of resolving delay ambiguity.

NOTE – The degree of the delay ambiguity resolution is subject to agreement by the implementing parties.

**6.4.3** The network element shall also be capable of performing PN ranging calibration.

NOTE – The calibration procedures are specific to the network element implementation and are not further specified in this recommendation.

## **6.5 PN TIME TRANSFER**

If the User employs PN Time transfer, the network element shall be capable of measuring the absolute UTC time of the transmitted range code (epoch) and the received range code (epoch).

NOTE – Use of the range PN code epoch times to determine the spacecraft clock error is described in the User Spacecraft Clock Calibration System (USCCS) (reference [\[C3\]](#)~~[C3]~~).

## **7 USER ELEMENT REQUIREMENTS FOR PN SPREADING**

### **7.1 OVERVIEW**

This section provides functional and performance requirements for User element equipment in a system employing CCSDS and SNIP standard PN Spread modulation formats relating to the PN spread signal formats used in this document. The User Transponder requirements and parameter values are provided to ensure compatibility with existing Network element PN spread modes.

### **7.2 GENERAL**

CCSDS transponder/transceiver equipment must be a transponder when coherent mode of operation is required; if non-coherent operation is used the User equipment may be a transceiver.

NOTE – This section provides only those parameter requirements relating to signal compatibility. As indicated in 1.2, Scope, there are other types of requirements, not specifically related to PN spread modulation signal formats such as limiting the power level to avoid false lock, which need to be met to ensure system compatibility with existing Network element hardware.

### **7.3 RECEIVE REQUIREMENTS**

**7.3.1** The CCSDS transponder/transceiver receiving system shall search for and acquire the I channel PN codes (short code) described in section 4.

**7.3.2** The receiving system shall be capable of de-spreading the short PN codes described in section 4.

**7.3.3** When using coherent mode of operation, the transponder shall be capable of providing coherent RF and PN turnaround capability to the transmitter.

**7.3.4** The CCSDS transponder shall be capable of providing coherent RF turnaround if Doppler tracking is required.

**7.3.5** If, in addition, range tracking is required, upon acquisition of the I (command) channel PN code and carrier, the CCSDS transponder receiving system shall search for and acquire the range channel PN code (long code) described in section 4:

- a) the receiving system shall be capable of de-spreading the long PN code;
- b) the CCSDS transponder shall be capable of providing PN epoch synchronization to the transmitter for ranging turnaround.

## 7.4 PERFORMANCE REQUIREMENTS

### 7.4.1 SHORT CODE ACQUISITION TIME

The CCSDS transponder/transceiver receiver shall acquire short code PN lock with a probability of 90 percent or greater within 20 seconds after arrival of the forward link transmission, assuming that the received signal is within  $\pm 1500$  Hz of the receiver best lock frequency.

### 7.4.2 LONG PN CODE ACQUISITION TIME

The receiver shall establish synchronization with the long PN code with a probability of at least 95 percent within 5 seconds after synchronization of the short code.

## 7.5 TRANSMIT REQUIREMENTS

**7.5.1** The CCSDS transponder/transceiver shall be capable of spreading symbols on I channel for mode 3, and on the I and Q channel for mode 1 using generated PN codes described in section 5.

**7.5.2** For platforms requiring range tracking and/or time transfer, the CCSDS transponder shall be capable of synchronizing the epoch of the transmitted I channel PN code to that of the received Q channel code.

**7.5.3** Both long and short return link codes shall be generated in the CCSDS transponder/transceiver in accordance with section 5.

**7.5.4** The transmit PN code and carrier shall be coherent with respect to each other for all modes of operation:

- a) For coherent forward link/return carrier operation, the carrier shall be phase shift key modulated by a long code PN sequence synchronized to the forward link.
- b) For non-coherent forward link/return link operation, the carrier shall be phase shift key modulated by a short code PN sequence.
- c) For mode 3, PN code modulation shall be disabled.

**7.5.5** The PN chip rate shall meet the requirements specified in table [5-15-1](#) for each of the services.

**7.5.6** When in coherent mode the transmitter shall turn automatically to non-coherent return link operation if the forward link signal is unlocked.

## **7.6 RANGING PERFORMANCE**

### **7.6.1 GENERAL**

**7.6.1.1** Each CCSDS transponder shall synchronize its return link PN Code epoch to the received forward link long PN code epoch for ranging and time transfer.

**7.6.1.2** The transponder must meet the timing requirements between these epochs specified in paragraphs 7.6.2 through 7.6.3.3.

### **7.6.2 ABSOLUTE TIME DELAY**

**7.6.2.1** The nominal absolute time delay ( $T_0$ ) between transmit and receive epochs shall be reported to the mission subsystem that does the orbit determination.

NOTE – The User element PN turnaround latency can be several microseconds without impacting the orbit determination as long as it is stable and reported.

**7.6.2.2** The User must also account for the delay from the antenna to the transponder and back to the antenna.

### **7.6.3 TIME DELAY VARIATION**

#### **7.6.3.1 General**

The CCSDS transponder shall be designed such that the time delay, when averaged over a 100-second interval, between transmit and receive epochs ( $T_0$ ) does not vary from its nominal value more than that specified for the network as a function of signal strength, carrier frequency, chip rate, or primary power supply voltage, either individually or in conjunction with the environmental parameters.

#### **7.6.3.2 Time Delay Repeatability**

The time delay for any specific set of signal, power cycling, and/or environmental parameters must be repeatable within  $\pm 10$  ns over an interval of 100 seconds or more.

#### **7.6.3.3 Short-Term Time Delay Jitter**

The time delay jitter shall not exceed 10 ns rms over an interval of 100 seconds or more.

## 7.7 TIME TRANSFER REQUIREMENTS

### 7.7.1 GENERAL

If the User element employs the USCCS, the User CCSDS transponder shall provide a PN code epoch output, as shown in figure 7-17-1, which coincides in time with the all '1's or epoch state of the forward link long code.

### 7.7.2 RISE AND FALL TIMES

The epoch signal rise and fall times shall not exceed 30 ns as measured at the 10 to 90 percent points (see figure 7-17-1).

### 7.7.3 EPOCH PERIOD

The period of the code (time between epochs) shall nominally be determined by the equation (see figure 7-17-1):

$$T_e = 1023 \times 256 / f_{PN} \approx 0.085 \text{ s}$$

where:  $f_{PN}$  is the PN chip rate in chips/s as determined from the received signal;

the duration of the time transfer epoch signal is nominally one PN chip;

$T_e$  is approximately 0.085 s.

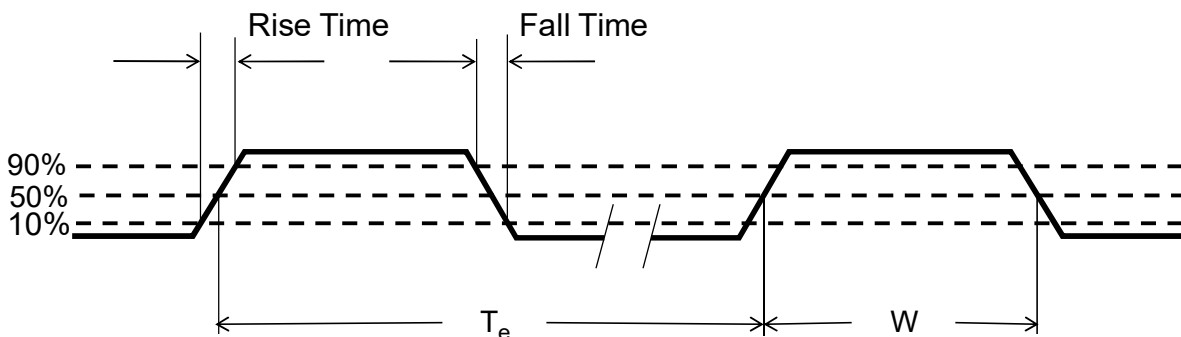

Rise Time should not exceed 30 nsec between the 10 and 90 percent points

$$T_e \text{ (code period)} = \frac{1023 \times 256}{f_{PN}} \quad W \text{ (duration of epoch)} = \text{one PN Chip}$$

$$f_{PN} = \frac{31 \times F_{\text{recv}}}{221 \times 96}$$

**Figure 7-1: Time Transfer Interface Timing Diagram**



## **7.7.4 EPOCH TIMING ACCURACY**

**7.7.4.1** The timing uncertainty between the epoch output and actual epoch transition of the receiver long code must be known to the User control center.

**7.7.4.2** The jitter component or sample-to-sample variation shall not exceed the User-required time correlation accuracy.

## **7.8 PN CODE PERFORMANCE**

### **7.8.1 PN CHIP RATE**

The PN chip rate requirements provided in tables [4-14-1](#) and [5-15-1](#) shall be met for forward and return services respectively.

### **7.8.2 PN CODE CHIP ALIGNMENT**

The forward I- and Q-channel PN chips shall be aligned and the return I- and Q-channel PN chips shall be staggered by half chip duration at the modulator input.

### **7.8.3 PN CODE ASYMMETRY**

The percent asymmetry between the 50 percent points of a high-to-low PN transition versus a low-to-high transition shall not exceed 1 percent.

### **7.8.4 PN CHIP JITTER**

**7.8.4.1** In coherent turnaround modes (modes 1 and 3), the User element transmitted PN chip jitter must not exceed 10 ns rms.

**7.8.4.2** For transmitter mode 2, the PN chip jitter must not exceed 4 ns rms.



## ANNEX A

### SECURITY, SANA, AND PATENT CONSIDERATIONS

#### (INFORMATIVE)

#### A1 SECURITY CONSIDERATIONS

##### A1.1 INTRODUCTION

From a security point of view, any radio frequency (RF) signal has several potential areas of concern: frequency jamming, spoofing, and interception and either modification or corruption. The PN CDMA spread spectrum command, telemetry, and tracking system is susceptible to these concerns but is likely to be less so than non-spread spectrum RF satellite links.

**RF jamming** refers to transmission of a radio signal that disrupts [communications](#) by decreasing the [signal to noise ratio](#) of the desired signal or by saturating the front end of the receiver. It is usually intentional but can, however, be unintentional. Jamming of the uplink and/or downlink CDMA signal could lead to the total loss of command, telemetry, and tracking data and potentially cause navigation errors.

**Spoofing** of the CDMA signal is when another signal successfully masquerades as a friendly one, by falsifying the signal format and data, and gains illegitimate access. This access can deposit incorrect command/telemetry or tracking data at the spacecraft or ground or simply confuse the true signal and have an effect similar to jamming but without the obvious signature that jamming would produce.

Both jamming and spoofing can result in incorrect spacecraft operation and incorrect trajectory determination and, in the worst case, could lead to the failure or loss of the mission.

**Interception** of the signal allows a third party access to unauthorized information. It is of primary concern on the forward (uplink) spacecraft commands since the science return (downlink) information is sometimes open to the public. Interception and either modification (spoofing) or corruption (jamming) of the forward signal results in both data and control loss and possible navigation errors. This could lead to incorrect trajectory determination and possible loss of mission.

##### A1.2 SECURITY CONCERNS WITH RESPECT TO THE CCSDS DOCUMENT

All radio signals are vulnerable to jamming, although spectrum spreading is generally considered to be a mitigating factor. The high altitude of a geostationary relay satellite makes it somewhat more difficult to jam than a LEO satellite, but the fact that a relay satellite is constantly in view makes jamming possible for a long duration. However, long duration jamming makes it easy to detect and find the jamming signal source. It is possible to jam the

User satellite, but since LEO satellites are moving at about 7.6 km/s, the satellite will move over the horizon in a few minutes and be out of range of the jamming signal.

Transmitting a forward spoofing signal from the ground to the relay satellite or directly to the User requires knowledge of the PN spread signals. Information in this document is one piece of the information needed to successfully spoof the system. The PN Code Library is maintained by the CCSDS Secretariat and not made publicly available.

### **A1.3 POTENTIAL THREATS AND ATTACK SCENARIOS**

Threats may come from intentional actions or from unwanted signals from other satellites or ground stations. Spread spectrum signals are susceptible to what is called the near-far problem. Other satellites that when using the system have a higher data rate and hence higher power, or are nearer to the receiving node and thus cause a higher power flux density can cause a false PN lock. This can deny service to one of the other users of the system.

Jamming, spoofing, and interception are all possible for near Earth satellites and for the relay satellite itself. The proximity of the User satellite to the Earth makes it susceptible to rogue signals from the Earth overpowering the desired signal from a distant relay satellite. It is also possible for rogue signals with the proper modulation and spread spectrum pattern to appear as an intended signal and spoof the User spacecraft receiver. Attack scenarios can be directed at the user command receiver, the User return signal as it is received at the relay satellite, the relay satellite itself, and the relay satellite ground station. Both the data portion of the signal and the orbit tracking (Doppler and/or ranging) portion of the signal can be compromised.

### **A1.4 CONSEQUENCES OF NOT APPLYING SECURITY TO THE TECHNOLOGY**

While these security issues are of concern, most of them are out of scope with respect to this document. This document specifies the PN spread spectrum CDMA physical layer. Providing protection for command and telemetry data and tracking data (range and/or Doppler) that is carried on the spread spectrum modulated channel should be done at higher layers. The consequences of not applying some method to provide security are loss of contact time, impaired ability to control the User satellite via loss of ability to command the satellite, loss of housekeeping or science data, and loss of tracking data. In a worst case scenario, this can cause loss of the mission.

Signal **integrity** provides protection against undetected alteration/modification of range measurements. If range measurement integrity is not implemented, erroneous range measurements may result, which in turn may cause loss or failure of the mission.

Signal **confidentiality** provides protection against both undetected modification as well as unauthorized disclosure of the command, telemetry, and ranging data. If confidentiality is not implemented, forward and/or return signals can be intercepted by unauthorized entities, allowing them to take control of the satellite and compromise the mission.

Physical-layer techniques such as DSSS and/or frequency hopping are used to accomplish protection against **jamming**. Since this document recommends a spread spectrum technique, some level of anti jamming security is inherent in the technique.

## **A2 SANA CONSIDERATIONS**

The recommendations of this document do not require any action from SANA.

## **A3 PATENT CONSIDERATIONS**

The modulation schemes specified by this Recommended Standard are not protected by patents and included already in CCSDS 401.0-B-20, *Radio Frequency and Modulation Systems—Part 1: Earth Stations and Spacecraft* (Blue Book, Issue 20, April 2009).

The specified Gold and maximal length CDMA codes are also not protected by patents as far as is known by the RF and Modulation WG.

However, there are probably hundreds of patents filed on specific methods to implement the recommended modulators, demodulators, CDMA encoders, and CDMA decoders.

Given the many missions by ESA, JAXA and NASA that have been or are currently flying under the SNIP agreement, it is well proven that many companies around the world have successfully implemented commercial products according to the proposed standard, and therefore have access to this technology.



## ANNEX B

### GLOSSARY

#### (INFORMATIVE)

##### B1 ABBREVIATIONS AND ACRONYMS

BPSK	Binary Phase Shift Keying
CCSDS	Consultative Committee For Space Data Systems
CDMA	Code Division Multiple Access
DG	Data Group
DSSS	Direct Sequence Spread Spectrum
ESA	European Space Agency
GEO	Geostationary Orbit
I/Q	I divided by Q
JAXA	Japan Aerospace Exploration Agency
LEO	Low Earth Orbit
LFSR	Linear Feedback Shift Register
MAI	Multiple Access Interference
MOC	Mission Operations Center
NASA	National Aeronautics and Space Administration
PFD	Power Flux Density
PN	Pseudo-random Noise
PSD	Power Spectral Density
QPN	QPSK (not staggered) with PN spreading
QPSK	Quadrature Phase Shift Keying
RF	Radio Frequency
rms	Root Mean Square
SFCG	Space Frequency Coordination Group
SN	Space Network
SNIP	Space Network Interoperability Panel

SQPN	Staggered Quadrature phase shift keyed PN modulation. Also called Staggered QPSK (SQPSK) with PN spreading or Offset QPSK (OQPSK) with PN spreading
SS	Spread Spectrum
TCXO	Temperature Compensated Crystal Oscillator
UQPSK	Unbalanced QPSK
USCCS	User Spacecraft Clock Calibration System
VCO	Voltage Controlled Oscillator

## B2 DEFINITIONS

**Balanced Code:** a PN code where the number of ‘1’s is equal to the number of ‘0’s plus one.

**CDMA:** Code Division Multiple Access. DSSS can be used to produce CDMA, a multiple access technique that allows multiple simultaneous Users to transmit over a single channel using a common center frequency where the use of different PN codes allow each signal to be independently recovered.

**Chip:** the ‘1’s and ‘0’s comprising the PN spreading code.

**Coherent and Non-coherent Modes:** In the system described, the PN code clock is synchronous with the RF carrier but the User data clock is not expected to be coherent with either. In a coherent RF link, the User element transmitted return link carrier frequency and PN code frequency (if applicable) are derived from the forward link carrier frequency received from the network element. For coherent PN spread return links, the return PN code length is identical to the length of the received forward service range channel PN code. The User return I channel PN code epoch is synchronized with the epoch of the received forward service range channel PN code.

For non-coherent modes, the CCSDS transponder/transceiver transmitted return link carrier frequency and PN code frequency (if applicable) are derived from an on-board local oscillator.

A User transceiver may be used for non-coherent service, whereas an RF (and in this document, PN) coherent radio referred to as a transponder is required for coherent service.

**Command Channel:** One of the quadrature channels on the forward link that carries the command data. Also see Range Channel. The power on the Command and Range channels is unbalanced with the command channel having ten times the power of the range channel.



**DG:** Data Group. DG refers to whether a signal is PN spread or not. For DG 1 at least one of the I or Q channel are spread. DG 2 is not spread and is therefore not covered in this standard.

**DSSS:** In direct sequence spread spectrum (DSSS) the spreading signal is a PN sequence. The bits in the data/symbol signal are modulo-2 added with the much higher rate PN code. This effectively increases the data/symbol rate and bandwidth of the transmitted signal to that of the modulated PN sequence. At the receiver, the received signal is multiplied (analog equivalent of modulo-2 add) by the same PN sequence to remove the spreading.

**Forward and Return Service:** Forward service is defined as that in which the data flows from the network element to a CCSDS User. Return service is defined as that in which the data flows from a CCSDS User to the network element.

**ks/s:** Spread spectrum links are rate  $\frac{1}{2}$ , constraint length 7, convolutionally encoded so the physical channel rates are specified in kilosymbols per second rather than kb/s.

**Maximal Length Code:** A PN code generated by a linear feedback shift register with N stages is limited in length by the maximum number of patterns that can be contained in the N registers to a length of  $2^N - 1$ . A maximum length pattern is generated only when the taps are chosen such that this length results. These codes have unique properties.

**Mode:** refers whether a return signal is coherent with the associated forward signal. In the case of radiometric tracking, coherent refers both RF and PN coherent. PN coherent allows the PN spreading code to be used for PN ranging. Mode 1 is coherent; Mode 2 is not coherent; Mode 3 is a hybrid where the RF is coherent and the I channel return PN is coherent with the forward but the Q channel return is unspread and hence not PN coherent.

**Modulo-2 Addition:** In this document the term Modulo-2 addition is used to refer to exclusive OR function and is also used for the analog case where levels are +1 and -1 instead of 1 and 0 and the signal levels are actually multiplied.

**Network Element:** Point in the network that transmits to and receives from a User element. (Generally a ground station but could be a satellite in a constellation environment.)

**PN Chip Asymmetry:**

$$\text{Asymmetry} = \frac{\text{duration of long chip} - \text{duration of short chip}}{\text{duration of long chip} + \text{duration of short chip}}$$

**PN Chip Jitter:** The unwanted phase variations of the PN code chip clock measured in degrees rms. A PN code chip clock with PN code chip jitter can be expressed as follows:

$$c(t) = \text{sgn}[\cos(2\pi f_{\text{pn}}t + \phi(t))]$$

where

$f_{\text{pn}}$  = desired PN code chip rate in Hz;

$\phi(t)$  = PN code chip clock phase jitter in radians.

The PN code chip jitter is the rms value of  $\phi(t)$  expressed in degrees.

**PN Chip Rate Error:** The peak deviation of the actual PN chip rate from the desired PN chip rate (where the desired PN chip rate is defined as the PN chip rate which results in absolute coherence with the carrier rate).

**PN Chip Skew:** PN chip skew is the deviation of the chip transitions between the I and Q channels from the ideal time delay.

**PN Power Suppression:** PN power suppression is the effective reduction in de-spread signal power due to the presence of timing imperfections (asymmetry, jitter and clock granularity) in the network and user platform transmitter PN clock. Under non-coherent conditions, jitter will be due to the User transmitter's oscillator. Under coherent turnaround conditions, it will also reflect forward link imperfections.

**Range Channel:** One of the quadrature channels on the forward link that carries only the long ranging PN code. Also see Command Channel.

**SN:** The Space Network is comprised of a space based set of relay satellites and a network ground element that passes tracking, data and timing information between the User satellite and the control or data center for the User satellite.

**SN Service Modes:** For the purpose of making this Recommended Standard applicable to the wider CCSDS community, some SNIP-specific terminology is defined. For the User-to-SN return link modes, Data Group 1 (DG1) Mode 1 refers to a spread spectrum (DG1) return, coherent with the forward link (Mode 1) service, with DSSS used on both the I and Q low symbol rate return channels. DG1 Mode 2 refers to a spread spectrum return non-coherent service, either because a forward service is lacking or because the transponder is configured with the return not coherent with the forward, with DSSS used on both the I and Q channels when symbol rates are at or below 300 ks/s. DG1 Mode 3 is a return service where the I channel is spread (DG1) and is coherent (mode 1) with the forward service and DSSS is used on the I channel when the symbol rate is at or below 300 ks/s, while the Q channel has a symbol rate greater than 300 ks/s and is not spread.

The Network element-to-User forward channel service mode consists of an I command channel and a Q range channel, both spread spectrum.

The User element-to-Network element return channel service mode consists of an I channel and a Q channel that may have unequal symbol rates and unequal power and may or may not be spread spectrum, depending on the symbol rate.

**Spread Spectrum:** Spread Spectrum (SS) is a family of communications techniques in which the RF bandwidth used to transmit a given data signal is much wider (typically more than 10 times wider) than what would normally be used with non-SS modulation techniques.

**Spurious codes:** The filtering and hard limiting of a staggered quadriphase PN (SQPN) signal can result in spurious PN sequences in the I and Q channel. These spurious codes are capable of causing false lock.

**User:** a satellite or its controlling authority that uses the network.



## ANNEX C

### INFORMATIVE REFERENCES

#### (INFORMATIVE)

- [C1] *Space Network Interoperable PN Code Libraries*. Revision 1. 451-PN CODE-SNIP. Greenbelt, Maryland: NASA Goddard Space Flight Center, November 1998.
- [C2] *Pseudo-Noise (PN) Ranging Systems*. Recommendation for Space Data System Standards, CCSDS 414.1-B-1. Blue Book. Issue 1. Washington, D.C.: CCSDS, March 2009.
- [C3] William Conaway and Victor J. Sank. *User Spacecraft Clock Calibration System (USCCS) Users' Guide*. Revision 3. 531-TR-001. Greenbelt, Maryland: NASA Goddard Space Flight Center, April 1999.
- [C4] *Tracking Data Message*. Recommendation for Space Data System Standards, CCSDS 503.0-B-1. Blue Book. Issue 1. Washington, D.C.: CCSDS, November 2007.

Appendix D

NON-REGENERATIVE RANGING AND LUNAR PROXIMITY

(NORMATIVE)

The schemes describe in this book are available for use in the Lunar environment. The schemes may be used between an orbiting User and a relay satellite or a Lunar surface element.

In addition to the regenerative ranging describe in this book, a scheme where the PN pattern is not regenerated at the receive node (spacecraft) may also be used. This appendix defines the details for non-regenerative (transparent) ranging. Non-regenerative ranging requires a better link quality than regenerative ranging.

Non-regenerative ranging may be done either with a command channel or without a command channel.

When done with a command channel, the forward link shall be as describe in earlier parts of the document.

When done without a command channel, the forward link shall be BPSK modulated with only the PN pattern.

The ranging PN pattern shall be the same pattern used on the forward link Range Channel (Q channel) as when doing regenerative ranging.

The forward range channel shall be demodulated and the chip pattern applied to the return link using BPSK modulation.