

Recommendation for Space Data System Standards

ORBIT DATA MESSAGES

PROPOSED STANDARD

CCSDS 502.0-P2.3940

PINK BOOK

~~December 2019~~October 2020 DRAFT

AUTHORITY

Issue:	Proposed Standard, Issue P2.3940
Date:	December 2019 <u>October 2020</u>
	DRAFT
Location:	Washington, DC, USA

This document has been approved for publication by the Management Council of the Consultative Committee for Space Data Systems (CCSDS) and represents the consensus technical agreement of the participating CCSDS Member Agencies. The procedure for review and authorization of CCSDS documents is detailed in the *Procedures Manual for the Consultative Committee for Space Data Systems*, and the record of Agency participation in the authorization of this document can be obtained from the CCSDS Secretariat at the address below.

This document is published and maintained by:

CCSDS Secretariat
Space Communications and Navigation Office, 7L70
Space Operations Mission Directorate
NASA Headquarters
Washington, DC 20546-0001, USA

STATEMENT OF INTENT

The Consultative Committee for Space Data Systems (CCSDS) is an organization officially established by the management of its members. The Committee meets periodically to address data systems problems that are common to all participants, and to formulate sound technical solutions to these problems. Inasmuch as participation in the CCSDS is completely voluntary, the results of Committee actions are termed **Recommended Standards** and are not considered binding on any Agency.

This **Recommended Standard** is issued by, and represents the consensus of, the CCSDS members. Endorsement of this **Recommendation** is entirely voluntary. Endorsement, however, indicates the following understandings:

- o Whenever a member establishes a CCSDS-related **standard**, this **standard** will be in accord with the relevant **Recommended Standard**. Establishing such a **standard** does not preclude other provisions which a member may develop.
- o Whenever a member establishes a CCSDS-related **standard**, that member will provide other CCSDS members with the following information:
 - The **standard** itself.
 - The anticipated date of initial operational capability.
 - The anticipated duration of operational service.
- o Specific service arrangements shall be made via memoranda of agreement. Neither this **Recommended Standard** nor any ensuing **standard** is a substitute for a memorandum of agreement.

No later than five years from its date of issuance, this **Recommended Standard** will be reviewed by the CCSDS to determine whether it should: (1) remain in effect without change; (2) be changed to reflect the impact of new technologies, new requirements, or new directions; or (3) be retired or canceled.

In those instances when a new version of a **Recommended Standard** is issued, existing CCSDS-related member standards and implementations are not negated or deemed to be non-CCSDS compatible. It is the responsibility of each member to determine when such standards or implementations are to be modified. Each member is, however, strongly encouraged to direct planning for its new standards and implementations towards the later version of the Recommended Standard.

FOREWORD

This document is a Recommended Standard for Orbit Data Messages (ODMs) and has been prepared by the Consultative Committee for Space Data Systems (CCSDS). The set of orbit data messages described in this Recommended Standard is the baseline concept for trajectory representation in data interchange applications that are cross-supported between Agencies of the CCSDS.

This Recommended Standard establishes a common framework and provides a common basis for the interchange of orbit and orbit-relevant data. It allows implementing organizations within each Agency to proceed coherently with the development of compatible derived standards for the flight and ground systems that are within their cognizance. Derived Agency standards may implement only a subset of the optional features allowed by the Recommended Standard and may incorporate features not addressed by this Recommended Standard.

Through the process of normal evolution, it is expected that expansion, deletion, or modification of this document may occur. This Recommended Standard is therefore subject to CCSDS document management and change control procedures, which are defined in the *Procedures Manual for the Consultative Committee for Space Data Systems*. Current versions of CCSDS documents are maintained at the CCSDS Web site:

<http://www.ccsds.org/>

Questions relating to the contents or status of this document should be addressed to the CCSDS Secretariat at the address indicated on page i.

At time of publication, the active Member and Observer Agencies of the CCSDS were:

Member Agencies

- Agenzia Spaziale Italiana (ASI)/Italy.
- British National Space Centre (BNSC)/United Kingdom.
- Canadian Space Agency (CSA)/Canada.
- Centre National d’Etudes Spatiales (CNES)/France.
- China National Space Administration (CNSA)/People’s Republic of China.
- Deutsches Zentrum für Luft- und Raumfahrt e.V. (DLR)/Germany.
- European Space Agency (ESA)/Europe.
- Russian Federal Space Agency (RFSA)/Russian Federation.
- Instituto Nacional de Pesquisas Espaciais (INPE)/Brazil.
- Japan Aerospace Exploration Agency (JAXA)/Japan.
- National Aeronautics and Space Administration (NASA)/USA.

Observer Agencies

- Austrian Space Agency (ASA)/Austria.
- Belgian Federal Science Policy Office (BFSP0)/Belgium.
- Central Research Institute of Machine Building (TsNIIMash)/Russian Federation.
- Centro Tecnico Aeroespacial (CTA)/Brazil.
- Chinese Academy of Sciences (CAS)/China.
- Chinese Academy of Space Technology (CAST)/China.
- Commonwealth Scientific and Industrial Research Organization (CSIRO)/Australia.
- CSIR Satellite Applications Centre (CSIR)/Republic of South Africa.
- Danish National Space Center (DNSC)/Denmark.
- European Organization for the Exploitation of Meteorological Satellites (EUMETSAT)/Europe.
- European Telecommunications Satellite Organization (EUTELSAT)/Europe.
- Geo-Informatics and Space Technology Development Agency (GISTDA)/Thailand.
- Hellenic National Space Committee (HNSC)/Greece.
- Indian Space Research Organization (ISRO)/India.
- Institute of Space Research (IKI)/Russian Federation.
- KFKI Research Institute for Particle & Nuclear Physics (KFKI)/Hungary.
- Korea Aerospace Research Institute (KARI)/Korea.
- Ministry of Communications (MOC)/Israel.
- National Institute of Information and Communications Technology (NICT)/Japan.
- National Oceanic and Atmospheric Administration (NOAA)/USA.
- National Space Organization (NSPO)/Chinese Taipei.
- Naval Center for Space Technology (NCST)/USA.
- Scientific and Technological Research Council of Turkey (TUBITAK)/Turkey.
- Space and Upper Atmosphere Research Commission (SUPARCO)/Pakistan.
- Swedish Space Corporation (SSC)/Sweden.
- United States Geological Survey (USGS)/USA.

DOCUMENT CONTROL

Document	Title	Date	Status
CCSDS 502.0-B-1	Orbit Data Messages, Issue 1	September 2004	Original issue, superseded
CCSDS 502.0- P2.3940	ORBIT DATA MESSAGES, Proposed Standard, Issue P2.3940	December 2019 October 2020	Current issue: – changes from the original issue are documented in ANNEX KL
EC 1	Editorial Change 1		Corrects erroneous cross references and table of contents entries; corrects typographical anomaly in annex D; updates informative references to current issues in ANNEX KL , Section K2L2
CCSDS 502.0.R-2, Cor. 1	Technical Corrigendum 1		Corrects/clarifies text; updates references [H]2 and [45] to current issues in 0.
CCSDS 502.0- P2.3940	Orbit Comprehensive Message SANA Registry for ODM Keyword values		Added Orbit Comprehensive Message (OCM) and transitioned ODM keyword values to SANA registry

CONTENTS

<u>Section</u>	<u>Page</u>
1 INTRODUCTION.....	1-11-1
1.1 PURPOSE AND SCOPE.....	1-11-1
1.2 APPLICABILITY.....	1-21-2
1.3 RATIONALE.....	1-21-2
1.4 DOCUMENT STRUCTURE.....	1-21-2
1.5 DEFINITIONS.....	1-4
1.5 CONVENTIONS AND DEFINITIONS.....	1-3
1.6 NOMENCLATURE.....	1-4
1.7 REFERENCES.....	1-5
2 OVERVIEW.....	2-71-5
2.1 ORBIT DATA MESSAGE TYPES.....	2-72-7
2.2 ORBIT PARAMETER MESSAGE (OPM).....	2-72-7
2.3 ORBIT MEAN-ELEMENTS MESSAGE (OMM).....	2-72-7
2.4 ORBIT EPHEMERIS MESSAGE (OEM).....	2-82-8
2.5 ORBIT COMPREHENSIVE MESSAGE (OCM).....	2-82-8
2.6 EXCHANGE OF MULTIPLE MESSAGES.....	2-92-9
2.7 DEFINITIONS.....	2-92-9
3 ORBIT PARAMETER MESSAGE (OPM).....	3-1
3.1 GENERAL.....	3-1
3.2 OPM CONTENT/STRUCTURE.....	3-2
3.3 OPM EXAMPLES AND SUPPLEMENTARY INFORMATION.....	3-9
4 ORBIT MEAN-ELEMENTS MESSAGE (OMM).....	4-1
4.1 GENERAL.....	4-1
4.2 OMM CONTENT/STRUCTURE.....	4-2
4.3 OMM EXAMPLES AND SUPPLEMENTARY INFORMATION.....	4-8
5 ORBIT EPHEMERIS MESSAGE (OEM).....	5-15-1
5.1 GENERAL.....	5-15-1
5.2 OEM CONTENT/STRUCTURE.....	5-15-1
5.3 OEM EXAMPLES AND SUPPLEMENTARY INFORMATION.....	5-8
6 ORBIT COMPREHENSIVE MESSAGE (OCM).....	5-8
6.1 GENERAL DESCRIPTION.....	6-1
6.2 OCM STRUCTURE AND OVERARCHING REQUIREMENTS.....	6-2
6.3 OCM EXAMPLES AND SUPPLEMENTARY INFORMATION.....	6-57
7 ORBIT DATA MESSAGE SYNTAX.....	7-1
7.1 OVERVIEW.....	7-1
7.2 GENERAL.....	7-1
7.3 ODM LINES.....	7-1
7.4 <u>ORBIT DATA MESSAGES IN “KEYWORD = VALUE NOTATION”</u> (I.E., NON-XML) AND ORDER OF ASSIGNMENT STATEMENTS.....	7-2
7.5 VALUES.....	7-3
7.6 UNITS IN THE ORBIT DATA MESSAGES.....	7-5
7.7 COMMENTS IN THE ORBIT DATA MESSAGES.....	7-7

7.8	ORBIT DATA MESSAGE KEYWORDS	7-8
8	CONSTRUCTING AN ODM/XML INSTANCE	8-1
8.1	OVERVIEW	8-1
8.2	XML VERSION	8-2
8.3	BEGINNING THE INSTANTIATION: ROOT ELEMENT TAG.....	8-2
8.4	THE STANDARD ODM/XML HEADER SECTION	8-3
8.5	THE ODM/ <u>XML</u> BODY SECTION	8-4
8.6	THE ODM/ <u>XML</u> METADATA SECTION	8-4
8.7	THE ODM/ <u>XML</u> DATA SECTION	8-4
8.8	CREATING AN OPM INSTANTIATION.....	8-4
8.9	CREATING AN OMM INSTANTIATION	8-7
8.10	CREATING AN OEM INSTANTIATION.....	8-9
8.11	CREATING AN OCM INSTANTIATION	8-12
8.12	CREATING A COMBINED INSTANTIATION	8-158-15
<u>8.13</u>	<u>SPECIAL SYNTAX RULES FOR ODM/XML</u>	<u>8-17</u>
ANNEX A	IMPLEMENTATION CONFORMANCE STATEMENT PRO FORMA (NORMATIVE)	A-1A-1
ANNEX B	NORMATIVE VALUES AND REFERENCES FOR TIMING SYSTEM, REFERENCE FRAME, ORBITAL ELEMENT, AND COVARIANCE- RELATED KEYWORDS (NORMATIVE)	B-1
ANNEX C	TECHNICAL MATERIAL (INFORMATIVE).....	C-1C-1
ANNEX D	OPM EXAMPLES (INFORMATIVE)	D-3
ANNEX E	OMM EXAMPLES (INFORMATIVE)	E-1
ANNEX F	OEM EXAMPLES (INFORMATIVE).....	F-1
ANNEX G	OCM EXAMPLES AND ASSOCIATED SUPPLEMENTARY INFORMATION (INFORMATIVE).....	G-1
ANNEX H	<u>AGGREGATING MULTIPLE ODMs IN A SINGLE NDM XML FILE</u> <u>(INFORMATIVE)</u>	<u>H-13</u>
<u>ANNEX I</u>	<u>ABBREVIATIONS AND ACRONYMS (INFORMATIVE)</u>	<u>I-17</u>
ANNEX <u>IJ</u>	RATIONALE FOR ORBIT DATA MESSAGES (INFORMATIVE)	J-1
ANNEX <u>JK</u>	ITEMS FOR AN INTERFACE CONTROL DOCUMENT (ICD) (INFORMATIVE)	K-1
ANNEX <u>KL</u>	CHANGES IN ODM VERSION 3 (INFORMATIVE)	L-1
ANNEX L	M-1	
ANNEX <u>M</u>	<u>M-1</u>	
<u>ANNEX N</u>	<u>INFORMATIVE REFERENCES (INFORMATIVE)</u>	<u>N-1N-1</u>

Figure

No table of contents entries found.

Table

3-1	OPM HEADER	3-3
3-2	OPM METADATA	3-4

3-3 OPM DATA.....	3-7
4-1 OMM HEADER.....	4-24-2
4-2 OMM METADATA.....	4-34-3
4-3 OMM DATA.....	4-5
5-1 OEM FILE LAYOUT SPECIFICATIONS.....	5-25-2
5-2 OEM HEADER.....	5-35-3
5-3 OEM METADATA.....	5-45-4
6-1 OEM METADATA.....	6-2
6-2 OEM METADATA.....	6-5
6-3 OEM METADATA.....	6-6
6-4 OEM METADATA.....	6-14
6-5 OEM METADATA.....	6-17
6-6 OEM METADATA.....	6-24
6-7 OEM METADATA.....	6-37
6-8 OEM METADATA.....	6-46
6-9 OEM METADATA.....	6-47
6-10 OEM METADATA.....	6-48
6-11 OEM METADATA.....	6-53
6-12 OEM METADATA.....	6-57
6-13 OEM METADATA.....	6-57
8-1 NDM/XML ROOT ELEMENT TAGS.....	8-28-2

1 INTRODUCTION

1.1 PURPOSE AND SCOPE

This Orbit Data Messages (ODM) Recommended Standard specifies four standard message formats for use in transferring spacecraft orbit information between space agencies and commercial or governmental spacecraft operators: the Orbit Parameter Message (OPM), the Orbit Mean-Elements Message (OMM), the Orbit Ephemeris Message (OEM), and the Orbit Comprehensive Message (OCM). Such exchanges are used for:

- a) pre-flight planning for tracking or navigation support;
- b) scheduling tracking support;
- c) carrying out tracking operations (sometimes called metric predicts);
- d) performing orbit comparisons;
- e) carrying out navigation operations such as orbit propagation and orbit reconstruction;
- f) assessing mutual physical and electromagnetic interference among satellites orbiting the same celestial body (~~currently~~ primarily Earth, Moon, and Mars at present);
- g) performing orbit conjunction (collision avoidance) studies; and
- h) developing and executing collaborative maneuvers to mitigate interference or enhance mutual operations.

This Recommended Standard includes sets of requirements and criteria that the message formats have been designed to meet. For exchanges where these requirements do not capture the needs of the participating agencies and satellite operators, another mechanism may be selected.

The Orbit Data Messages (ODM) standard is an international standard published under the auspices of CCSDS and International Standards Organization (ISO) Technical Committee 20, Subcommittee 13, developed jointly and in concert with the ISO TC20/SC14. As such, this CCSDS standard is also properly labeled as ISO 26900.

The recommended Orbit Data Message format is ASCII (reference [34]).

This ODM document describes both 'Keyword = Value Notation' (or KVN) as well as Extensible Markup Language (XML, reference [45]) formatted messages. Selection of KVN or XML format should be specified in an ICD mutually agreed between message exchange partners.

NOTE – As currently specified, an OPM, OMM, or OEM file is to represent orbit data for a single spacecraft and the OCM is to represent orbit data for either a single spacecraft or single parent spacecraft of a parent/child spacecraft deployment scenario. It is possible that the architecture may support multiple spacecraft per file; this could be considered in the future.

1.2 APPLICABILITY

The Orbit Data Message family of standardized orbit messages is applicable to all phases of the spacecraft and launch vehicle life cycle. The rationale behind the design of each particular orbit data message is described in ANNEX IJ and may help the application engineer to select a suitable message. Definition of the orbit accuracy underlying a particular orbit message is outside of the scope of this Recommended Standard and should be ~~specified via Interface Control Document (ICD)~~mutually agreed between datamessage exchange partners participants (or specified via COMMENT sections in the message itself). Applicability information specific to each orbit data message format appears in sections 3, 4, ~~and 5,~~ and 6 as well as in IJ2.4.

This Recommended Standard is applicable only to the message format and content, but not to its transmission. The transmission of the message between agencies and operators is outside the scope of this document and should be ~~specified in the ICD~~mutually agreed between message exchange partners.

Description of the message formats based on the use of Extensible Markup Language (XML) is detailed in Section 8.

1.3 RATIONALE

This update to version 2 of the Orbit Data Messages adds a fourth message type (OCM) based on collaboration of the CCSDS Navigation Working Group and the ISO Technical Committee 20, Subcommittee 14, Working Group 3 (ISO TC20/SC14/WG3). A full list of the changes in this document is located in ANNEX KL.

1.4 DOCUMENT STRUCTURE

Section 02 provides a brief overview of the CCSDS-recommended Orbit Data Message types, the Orbit Parameter Message (OPM), Orbit Mean-Elements Message (OMM), Orbit Ephemeris Message (OEM₂), and the Orbit Comprehensive Message (OCM).

Section 3 provides details about the structure and content of the OPM.

Section 4 provides details about the structure and content of the OMM.

Section 5 provides details about the structure and content of the OEM.

Section 6 provides details about the structure and content of the OCM.

Section 7 discusses the syntax considerations of the set of Orbit Data Messages (OPM, OMM, OEM₂, and OCM).

Section 8 provides details on the XML instantiations of the OPM, OMM, OEM₂, and OCM.

Following the principal content of the document, there are a number of annexes, both normative and informative, to guide the ODM user.

1.5 CONVENTIONS AND DEFINITIONS

1.5.1 NOTATION

1.5.1.1 Unit Notations

The following conventions for unit notations apply throughout this Recommended Standard, with message-specific guidance provided in Section 7-5. Units are drawn from the International System of Units (SI); units are either SI base units, SI derived units, or units outside the SI that are accepted for use with the SI [1]. Except as noted, the units used within this document are as follows:

- d: days, 86400 SI seconds;
- kg: kilograms;
- km: kilometers;
- m: meters;
- n/a: (units are not applicable)
- %: percent.
- s: SI seconds;
- SFU: Solar Flux Units
- W: watts;

1.5.1.2 General

The following notational conventions are used in this document:

- a) multiplication of units is denoted with a single asterisk ‘*’ (e.g., ‘kg*s’);
- b) exponents of units are denoted with a double asterisk ‘**’ (e.g., $m^2 = m^{**2}$);
- c) division of units is denoted with a single forward slash ‘/’ (e.g., m/s).

1.5.2 NOMENCLATURE

The following conventions apply for the normative specifications in this Manual:

- a) the words ‘shall’ and ‘must’ imply a binding and verifiable specification;
- b) the word ‘should’ implies an optional, but desirable, specification;

c) the word ‘may’ implies an optional specification;

d) the words ‘is’, ‘are’, and ‘will’ imply statements of fact.

NOTE – These conventions do not imply constraints on diction in text that is clearly informative in nature.

1.51.5.3 DEFINITIONS

For the purposes of this document, the following definitions apply:

- a) the word ‘agencies’ may also be construed as meaning ‘satellite operators’ or ‘satellite service providers’;
- b) the word ‘participant’ denotes an entity that has the ability to acquire or broadcast navigation messages and/or radio frequencies, for example, a spacecraft, a tracking station, a tracking instrument, or an agency/operator;
- c) the notation ‘n/a’ signifies ‘not applicable’;
- d) depending on context, the term ‘ODM’ may be used to refer to this document, or may be used to refer collectively to the OPM, OMM, OEM, and OCM messages.
- e) An 'observation' is a unique measurement set of a satellite’s state from a single sensor configuration at a single time (e.g. azimuth from a single sensor at a single time).
- f) A 'sensor track' is a set of observations within a specified number of minutes for the same object, observed by the same sensor configuration, where each observation is within a specified number of minutes (which is dependent on the orbit regime of the object) of the other observations in the track (e.g. a set of 10 two-way transponder range measurements from the same sensor using the same transponder on the satellite), where the number of minutes could alternately be defined as the time between start and stop of the measurement “session” or signal modulation that enables metric tracking.

1.61.1.1 NOMENCLATURE

~~The following conventions apply for the normative specifications in this Manual:~~

~~a) the words ‘shall’ and ‘must’ imply a binding and verifiable specification;~~

~~b) the word ‘should’ implies an optional, but desirable, specification;~~

~~c) the word ‘may’ implies an optional specification;~~

~~d) the words ‘is’, ‘are’, and ‘will’ imply statements of fact.~~

~~NOTE – These conventions do not imply constraints on diction in text that is clearly informative in nature.~~

1.71.6 REFERENCES

The following documents contain provisions which, through reference in this text, constitute provisions of this Recommended Standard. At the time of publication, the editions indicated were valid. All documents are subject to revision, and users of this Recommended Standard are encouraged to investigate the possibility of applying the most recent editions of the documents indicated below. The CCSDS Secretariat maintains a register of currently valid CCSDS Recommended Standards.

- [+1] [The International System of Units \(SI\). 8th ed. Sèvres, France: BIPM, 2006.](#)
- [2] *Time Code Formats*. Recommendation for Space Data System Standards, CCSDS 301.0-B-4. Blue Book. Issue 4. Washington, D.C.: CCSDS, November 2010.
- [3] *United Nations Office of Outer Space Affairs satellite designator/index, searchable at* <<http://www.unoosa.org/oosa/osoindex> >
- [4] *Information Technology—8-Bit Single-Byte Coded Graphic Character Sets—Part 1: Latin Alphabet No. 1*. International Standard, ISO/IEC 8859-1:1998. Geneva: ISO, 1998.
- [5] *XML Specification for Navigation Data Messages*. Recommendation for Space Data System Standards, CCSDS 505.0-B-1. Blue Book. Issue 1. Washington, D.C.: CCSDS, December 2010.
- [6] Paul V. Biron and Ashok Malhotra, eds. *XML Schema Part 2: Datatypes*. 2nd Edition. W3C Recommendation. N.p.: W3C, October 2004. <<http://www.w3.org/TR/2001/REC-xmlschema-2-20010502/>>
- [7] *IEEE Standard for Binary Floating-Point Arithmetic*. IEEE Std 754-1985. New York: IEEE, 1985.
- [8] Henry S. Thompson, et al. eds. *XML Schema Part 1: Structures*. 2nd ed. W3C Recommendation. N.p.: W3C, October 2004.
- [9] CCSDS 503.0-B-1, Tracking Data Message, November 2007.
- [10] CCSDS 504.0-B-1, Attitude Data Message, May 2008.
- [11] SANA Navigation Working Group Registry:
https://sanaregistry.org/r/navigation_standard_normative_annexes
- ~~[11] SANA Registry of Organizations: <https://sanaregistry.org/r/organizations>~~
- ~~[12] SANA Registry of Orbit Centers: https://sanaregistry.org/r/orbit_centers~~
- ~~[13] SANA Registry of Time Systems: https://sanaregistry.org/r/time_systems~~

[14] SANA Registry of Celestial Body Reference Frames:

https://sanaregistry.org/r/celestial_body_reference_frames

[15] SANA Registry of Orbit Relative Reference Frames:

https://sanaregistry.org/r/orbit_relative_reference_frames

[16] SANA Registry of Spacecraft and Attitude Control Reference Frames:

https://sanaregistry.org/r/spacecraft_reference_frames

[17] SANA Registry of Orbital Elements: https://sanaregistry.org/r/orbital_elements

[18] SANA Registry of Covariance Representations:

https://sanaregistry.org/r/orbital_covariance_matrix_types

[19] SANA Registry of Atmosphere Models: https://sanaregistry.org/r/atmosphere_models

[20] SANA Registry of Gravity Models: https://sanaregistry.org/r/gravity_models

[21] SANA Registry of Object Types: https://sanaregistry.org/r/orbital_covariance_matrix_types

[22] SANA Registry of Operational Status of Space Object:

https://sanaregistry.org/r/operational_status

[23] SANA Registry of Orbit Averaging Techniques: https://sanaregistry.org/r/orbit_averaging

[24] SANA Registry of Orbit Types: https://sanaregistry.org/r/orbit_types

2 OVERVIEW

2.1 ORBIT DATA MESSAGE TYPES

2.2 ORBIT PARAMETER MESSAGE (OPM)

An OPM specifies the position and velocity of a single object at a specified epoch. Optionally, osculating Keplerian elements may be provided. Note that a sequence of OPMs for either a single object or for multiple objects may be aggregated into a single Navigation Data Message (NDM) XML file as shown in ANNEX H. This message is suited to exchanges that (1) involve automated interaction and/or human interaction, and (2) do not require high-fidelity dynamic modeling.

The OPM requires the use of a propagation technique to determine the position and velocity at times different from the specified epoch, leading to a higher level of effort for software implementation than for the OEM. A 6x6 position/velocity covariance matrix that may be used in the propagation process is optional.

The OPM allows for modeling of any number of maneuvers (as both finite and instantaneous events) and simple modeling of solar radiation pressure and atmospheric drag.

The OPM also contains an optional covariance matrix which reflects the uncertainty of the orbit state.

Though primarily intended for use by computers, the attributes of the OPM also make it suitable for applications such as exchanges by email, FAX or voice, or applications where the message is to be frequently interpreted by humans.

2.3 ORBIT MEAN-ELEMENTS MESSAGE (OMM)

An OMM specifies the orbital characteristics of a single object at a specified epoch, expressed in mean Keplerian elements. ~~This message~~Note that a sequence of OMMs for either a single object or for multiple objects may be aggregated into a single Navigation Data Message (NDM) XML file as shown in ANNEX H. The OMM is suited to exchanges that (1) involve automated interaction and/or human interaction, and (2) do not require high-fidelity dynamic modeling. Such exchanges may be inter-agency exchanges, or ad hoc exchanges among satellite operators when interface control documents have not been negotiated. Ad hoc interactions usually involve more than one satellite, each satellite controlled and operated by a different operating authority.

The OMM includes keywords and values that can be used to generate canonical NORAD Two Line Element Sets (TLEs) to accommodate the needs of heritage users (see ~~reference [M-3]~~ANNEX N, Reference [N-3]).

The OMM also contains an optional covariance matrix which reflects the uncertainty of the mean Keplerian elements. This information may be used to determine contact parameters that encompass uncertainties in predicted future states of orbiting objects of interest.

This message is suited for directing antennas and planning contacts with satellites. It is not recommended for assessing mutual physical or electromagnetic interference among Earth-orbiting spacecraft, developing collaborative maneuvers, or propagating precisely the orbits of active satellites, inactive man-made objects, and near-Earth debris fragments. It is not suitable for numerical integration of the governing equations.

Though primarily intended for use by computers, the attributes of the OMM also make it suitable for applications such as exchanges by email, FAX, or voice, or applications where the message is to be frequently interpreted by humans.

2.4 ORBIT EPHEMERIS MESSAGE (OEM)

An OEM specifies the position and velocity of a single object at multiple epochs contained within a specified time range. Note that a sequence of OEMs for either a single object or for multiple objects may be aggregated into a single Navigation Data Message (NDM) XML file as shown in ANNEX H. The OEM is suited to exchanges that (1) involve automated interaction (e.g., computer-to-computer communication where frequent, fast automated time interpretation and processing is required), and (2) require higher fidelity or higher precision dynamic modeling than is possible with the OPM.

The OEM allows for dynamic modeling of any number of gravitational and non-gravitational accelerations. The OEM requires the use of an interpolation technique to interpret the position and velocity at times different from the tabular epochs.

The OEM also contains an optional covariance matrix which reflects the uncertainty of the orbit solution used to generate states in the ephemeris.

2.5 ORBIT COMPREHENSIVE MESSAGE (OCM)

An OCM specifies position and velocity of either a single object or an en masse parent/child deployment scenario stemming from a single object. ~~The OCM aggregates and extends OPM, OEM and OMM content in a single comprehensive hybrid message (file) and offers the following additional capabilities:~~ Note that a sequence of OCMs for either a single object or for multiple objects may be aggregated into a single Navigation Data Message (NDM) XML file as shown in ANNEX H.

The OCM aggregates and extends OPM, OEM, and OMM content in a single comprehensive hybrid message (file) and includes the following additional capabilities:

- Optional Earth Orientation (UT1 and UTC) at a nearby (relevant) reference epoch;
- Optional Leap second specification
- Optional area cross-sections for drag, SRP perturbations modeling.

- Optional spacecraft dimensions and orientation information for collision probability estimation
- ~~- Optional perturbations model specification;~~
- ~~- Optional maneuver specification (impulsive or finite burn);~~
- Optional orbit states (specified using one or more of Cartesian and orbit elements and reference frames) for a single or parent object at either a single epoch or as a time history (ephemeris);
- ~~- Optional orbit determination data and metrics;~~
- Optional covariance matrix of selectable/arbitrary order for a single or parent object at either a single epoch or as a time history (ephemeris) which reflects the uncertainty of the orbit solution or simulation used to obtain the nominal states in the orbit state(s);
- Optional covariance content options (e.g. Cartesian 3x3, 6x6, 7x7, or any combination of order, reference frame and orbit elements)
- ~~- Optional State Transition Matrix specification;~~
- ~~- Optional maneuver specification (impulsive or finite burn);~~
- ~~- Optional perturbations model specification;~~
- ~~- Optional orbit determination data and metrics;~~

The OCM simultaneously emphasizes flexibility and message conciseness by offering extensive optional content while minimizing mandatory content. The OCM is well-suited for exchanges that (1) involve automated interaction (e.g., computer-to-computer communication where frequent, fast automated time interpretation and processing is required), and (2) involve regular orbit data transfer for numerous objects (e.g. 200,000) using minimal network bandwidth, disk storage, and quantity of files. The OCM allows the user, in a single message/file, to either embed high-fidelity orbit propagation into an ephemeris time history (akin to the OEM ephemeris), or specify orbital states which can be propagated with supplied perturbations model parameters (akin to OPM content), or both.

2.6 EXCHANGE OF MULTIPLE MESSAGES

For a given object, multiple OPM, OMM, or OEM messages may be provided in a message exchange session to achieve ephemeris fidelity requirements, whereas a single, self-contained OCM may be sufficient. If ephemeris information for multiple objects is to be exchanged, then multiple OPM, OMM, OEM, or OCM files must be used, with the exception that the OCM supports parent/child deployment scenario specifications in a single message.

2.7 DEFINITIONS

Definitions of time systems, reference frames, planetary models, maneuvers, and other fundamental topics related to the interpretation and processing of state vectors and spacecraft ephemerides are provided in ~~reference [M-1]-ANNEX N, Reference [N-1]~~.

3 ORBIT PARAMETER MESSAGE (OPM)

3.1 GENERAL

3.1.1 Orbit information may be exchanged between two participants by sending a state vector (see ~~reference [M-1]~~ANNEX N, Reference [N-1]) for a specified epoch using an Orbit Parameter Message (OPM). The message recipient must have an orbit propagator available that is able to propagate the OPM state vector to compute the orbit at other desired epochs. For this propagation, additional ancillary information (spacecraft properties such as mass, area, and maneuver planning data, if applicable) may be included with the message.

3.1.2 Osculating Keplerian elements and the Gravitational Coefficient may be included in the OPM in addition to the Cartesian state to aid the message recipient in performing consistency checks. If any Keplerian element is included, the entire set of elements must be provided.

3.1.3 If participants wish to exchange mean element information, then the Orbit Mean-Elements Message (OMM) or Orbit Comprehensive Message (OCM) should be the selected message type. (See sections 4 and 6.)

3.1.4 The use of the OPM is best applicable under the following conditions:

- a) an orbit propagator consistent with the models used to develop the orbit data should be available at the receiver's site;
- b) the receiver's modeling of gravitational forces, solar radiation pressure, atmospheric drag, and thrust phases (see ~~reference [M-1]~~ANNEX N, Reference [N-1]) should fulfill accuracy requirements established between the exchange partners.

3.1.5 The OPM shall be a plain text file consisting of orbit data for a single object.

NOTE: A sequence of OPMs for either a single object or for multiple objects may be aggregated into a single Navigation Data Message (NDM) XML file as shown in ANNEX H.

3.1.6 The OPM file-naming scheme should be mutually agreed ~~to on a case-by-case basis~~ between ~~the~~message exchange partners, ~~and should be documented in an ICD.~~

~~3.1.6.3.1.7~~ **3.1.7** The method of exchanging OPMs should be ~~decided on a case-by-case basis by~~ the mutually agreed between message exchange partners ~~and documented in an ICD.~~

NOTE— 1: Detailed syntax rules for the OPM are specified in section 77.

NOTE 2: Example OPMs and associated supplementary (non-normative) information are provided in ANNEX D.

3.2 OPM CONTENT/STRUCTURE

3.2.1 GENERAL

The OPM shall be represented as a combination of the following:

- a) a header;
- b) metadata (data about data);
- c) data with optional User-Defined Parameters; and
- d) optional comments (explanatory information).

3.2.2 OPM HEADER

3.2.2.1 Table 3-1 specifies for each header item:

- a) the keyword to be used;
- b) a short description of the item;
- c) examples of allowed values; and
- d) whether the item is Mandatory (M), Optional (O), or Conditional (C). Conditional means that if the delineated conditions are met, the item is mandatory-or optional.

3.2.2.2 Only those keywords shown in table 3-1 shall be used in an OPM header.

Table 3-1: OPM Header

Keyword	Description	Examples of Values	Mandatory M/O/C
CCSDS_OPM_VERS	Format version in the form of 'x.y', where 'y' is incremented for corrections and minor changes, and 'x' is incremented for major changes.	2 3.0	Yes M
COMMENT	Comments (allowed in the OPM Header only immediately after the OPM version number). (See 7.7 for formatting rules.)	This is a comment	No O
CREATION_DATE	File creation date/time in UTC. (For format specification, see 7.5.10)	2001-11-06T11:17:33 2002-204T15:56:23Z	Yes M
ORIGINATOR	Creating agency or operator. Select from the accepted set of values indicated in ANNEX B, Section B1.	CNES, ESOC, GSFC, GSOC, JPL, JAXA, INTELSAT, USAF, INMARSAT	Yes M
MESSAGE_ID	<u>ID that uniquely identifies a message from a given originator. The format and content of the message identifier value are at the discretion of the originator.</u>	OPM 201113719185 <u>ABC-12_34</u>	<u>O</u>

3.2.3 OPM METADATA

Table 3-2 specifies for each metadata item:

- a) the keyword to be used;
- b) a short description of the item;
- c) examples of allowed values; and
- d) whether the item is Mandatory (M), Optional (O), or Conditional (C). Conditional means that if the delineated conditions are met, the item is mandatory~~or optional~~.

3.2.3.1 Only those keywords shown in table 3-2 shall be used in OPM metadata.

NOTE – For some keywords (OBJECT_NAME, OBJECT_ID) there are no definitive lists of authorized values maintained by a control authority; the references listed in 1.7 are the best known sources for authorized values to date. For the TIME_SYSTEM and REF_FRAME keywords, see ANNEX B, Section B3 and Section B4 respectively, for guidance and a link to the approved set of values.

Table 3-2: OPM Metadata

CCSDS PROPOSED STANDARD FOR ORBIT DATA MESSAGES

Keyword	Description	Examples of Values	Mandatory M/O/C
COMMENT	Comments (allowed at the beginning of the OPM Metadata). (See 7.7 for formatting rules.)	This is a comment	No <u>O</u>
MESSAGE_ID	ID that uniquely identifies a message from a given originator. The format and content of the message identifier value are at the discretion of the originator.	OPM 201113719185 ABC 12_34	No
OBJECT_NAME	Spacecraft name for which the orbit state is provided. While there is no CCSDS-based restriction on the value for this keyword, it is recommended to use names from the UN Office of Outer Space Affairs designator index (reference [2], which include Object name and international designator of the participant-).	EUTELSAT W1 MARS PATHFINDER STS 106 NEAR	Yes <u>M</u>
OBJECT_ID	Object identifier of the object for which the orbit state is provided. There is no CCSDS-based restriction on the value for this keyword, but values should be the international spacecraft designator as published in the UN Office of Outer Space Affairs designator index (reference [2] -[3]). Recommended values have the format YYYY-NNNP{PP}, where: YYYY = Year of launch. NNN = Three digit serial number of launch in year YYYY (with leading zeros). P{PP} = At least one letter for the identification of the part brought into space by the launch. In cases where the asset is not listed in reference 3 , the UN Office of Outer Space Affairs designator index or that index -format is not used, OBJECT_ID terminology or the content cannot be disclosed, the value should be mutually agreed in an ICD -set to UNKNOWN.	2000-052A 1996-068A 2000-053A 1996-008A	Yes <u>M</u>
CENTER_NAME	Origin of the orbitOPM reference frame, which mayshall be a natural solar system body (planets, asteroids, comets, and natural satellites), including any planet barycenter or the solar system barycenter, or another reference frame center (such as a spacecraft, ground station, formation flying reference "chief" spacecraft, etc.). _ Natural bodies shall be selected from the accepted set of values indicated in ANNEX B, Section B2. For spacecraft, it is recommended to use either the Object name or international designator of the participant as catalogued in the UN Office of Outer Space Affairs designator index (reference [2]). Alternately, the OBJECT_DESIGNATOR may be used. For other reference frame origins, this field is a free text descriptor which can draw upon ground station name, etc.	EARTH EARTH BARYCENTER MOON SOLAR SYSTEM BARYCENTER SUN ISS JUPITER BARYCENTER EROSMARS <u>MOON</u>	Yes <u>M</u>

Keyword	Description	Examples of Values	Mandatory <u>M/O/C</u>
REF_FRAME	Reference frame in which the state vector and optional Keplerian element data are given. Select from the accepted set of values indicated in ANNEX B, Section B4.	ICRF1 ITRF2000 J2000 TEMEOFDATE	Yes <u>M</u>
REF_FRAME_EPOCH	Epoch of reference frame, if not intrinsic to the definition of the reference frame. (See 7.5.10 for formatting rules.)	2001-11-06T11:17:33 2002-204T15:56:23Z	No <u>O</u>
TIME_SYSTEM	Time system used for state vector, maneuver, and covariance data (also see table 3-3). Select from the accepted set of values indicated in ANNEX B, Section B3.	UTC, TAI, TT, GPS, TDB, TCB	Yes <u>M</u>

3.2.4 OPM DATA

3.2.4.1 Table 3-3 provides an overview of the six logical blocks in the OPM Data section (State Vector, Osculating Keplerian Elements, Spacecraft Parameters, Position/Velocity Covariance Matrix, Maneuver Parameters, and User Defined Parameters), and specifies for each data item:

- a) the keyword to be used;
- b) a short description of the item;
- c) the units to be used;
- d) whether the item is Mandatory (M), Optional (O), or Conditional (C). Conditional means that if the delineated conditions are met, the item is mandatory~~or optional~~.

3.2.4.2 Only those keywords shown in table 3-3 shall be used in OPM data.

NOTE – Requirements relating to the keywords in table 3-3 appear after the table.

Table 3-3: OPM Data

Keyword	Description	Units	Mandatory M/O/C
State Vector Components in the Specified Coordinate System			
COMMENT	(See 7.7 for formatting rules.)	n/a	NoO
EPOCH	Epoch of state vector & optional Keplerian elements. (See 7.5.10 for formatting rules.)	n/a	YesM
X	Position vector X-component	km	YesM
Y	Position vector Y-component	km	YesM
Z	Position vector Z-component	km	YesM
X_DOT	Velocity vector X-component	km/s	YesM
Y_DOT	Velocity vector Y-component	km/s	YesM
Z_DOT	Velocity vector Z-component	km/s	YesM
Osculating Keplerian Elements in the Specified Reference Frame (none or all parameters of this block must be given.)			
COMMENT	(See 7.7 for formatting rules.)	n/a	NoO
SEMI_MAJOR_AXIS	Semi-major axis	km	NoO
ECCENTRICITY	Eccentricity	n/a	NoO
INCLINATION	Inclination	deg	NoO
RA_OF_ASC_NODE	Right ascension of ascending node	deg	NoO
ARG_OF_PERICENTER	Argument of pericenter	deg	NoO
TRUE_ANOMALY or MEAN_ANOMALY	True anomaly or mean anomaly	deg	NoO
GM	Gravitational Coefficient (Gravitational Constant x Central Mass)	km**3/s**2	NoO
Spacecraft Parameters			
COMMENT	(See 7.7 for formatting rules.)	n/a	NoO
MASS	Spacecraft mass	kg	NoC
SOLAR_RAD_AREA	Solar Radiation Pressure Area (A _R)	m**2	NoC
SOLAR_RAD_COEFF	Solar Radiation Pressure Coefficient (C _R)	n/a	NoC
DRAG_AREA	Drag Area (A _D)	m**2	NoC
DRAG_COEFF	Drag Coefficient (C _D)	n/a	NoC
Position/Velocity Covariance Matrix (6x6 Lower Triangular Form. None or all parameters of the matrix must be given. COV_REF_FRAME may be omitted if it is the same as REF_FRAME.)			
COMMENT	(See 7.7 for formatting rules.)	n/a	NoO
COV_REF_FRAME	Reference frame in which the covariance data are given. Select from the accepted set of values indicated in ANNEX B, Sections B4 and B5.	n/a	NoO
CX_X	Covariance matrix [1,1]	km**2	NoC
CY_X	Covariance matrix [2,1]	km**2	NoC
CY_Y	Covariance matrix [2,2]	km**2	NoC
CZ_X	Covariance matrix [3,1]	km**2	NoC
CZ_Y	Covariance matrix [3,2]	km**2	NoC
CZ_Z	Covariance matrix [3,3]	km**2	NoC
CX_DOT_X	Covariance matrix [4,1]	km**2/s	NoC
CX_DOT_Y	Covariance matrix [4,2]	km**2/s	NoC
CX_DOT_Z	Covariance matrix [4,3]	km**2/s	NoC
CX_DOT_X_DOT	Covariance matrix [4,4]	km**2/s**2	NoC
CY_DOT_X	Covariance matrix [5,1]	km**2/s	NoC
CY_DOT_Y	Covariance matrix [5,2]	km**2/s	NoC
CY_DOT_Z	Covariance matrix [5,3]	km**2/s	NoC

Keyword	Description	Units	Mandatory M/O/C
CY_DOT_X_DOT	Covariance matrix [5,4]	km**2/s**2	<u>NeC</u>
CY_DOT_Y_DOT	Covariance matrix [5,5]	km**2/s**2	<u>NeC</u>
CZ_DOT_X	Covariance matrix [6,1]	km**2/s	<u>NeC</u>
CZ_DOT_Y	Covariance matrix [6,2]	km**2/s	<u>NeC</u>
CZ_DOT_Z	Covariance matrix [6,3]	km**2/s	<u>NeC</u>
CZ_DOT_X_DOT	Covariance matrix [6,4]	km**2/s**2	<u>NeC</u>
CZ_DOT_Y_DOT	Covariance matrix [6,5]	km**2/s**2	<u>NeC</u>
CZ_DOT_Z_DOT	Covariance matrix [6,6]	km**2/s**2	<u>NeC</u>
Maneuver Parameters (Repeat for each maneuver)			
COMMENT	(See 7.7 for formatting rules.)	n/a	<u>NeO</u>
MAN_EPOCH_IGNITION	Epoch of ignition. (See 7.5.10 for formatting rules.)	n/a	<u>NeO</u>
MAN_DURATION	Maneuver duration (If = 0, impulsive maneuver)	s	<u>NeO</u>
MAN_DELTA_MASS	Mass change during maneuver -(value is < 0)	kg	<u>NeO</u>
MAN_REF_FRAME	Reference frame in which the velocity increment vector data are given. Select from the accepted set of values indicated in ANNEX B, Sections B4 and B5.	n/a	<u>NeO</u>
MAN_DV_1	1 st component of the velocity increment	km/s	<u>NeO</u>
MAN_DV_2	2 nd component of the velocity increment	km/s	<u>NeO</u>
MAN_DV_3	3 rd component of the velocity increment	km/s	<u>NeO</u>
User Defined Parameters (all parameters in this section must be described in an ICD).			
USER_DEFINED_x	User defined parameter, where 'x' is replaced by a variable length user specified character string. Any number of user defined parameters may be included, if necessary to provide essential information that cannot be conveyed in COMMENT statements. Example: USER_DEFINED_EARTH_MODEL = WGS-84	n/a	<u>NeO</u>

3.2.4.3 All values except Maneuver Parameters in the OPM data are ‘at epoch’, i.e., the value of the parameter at the time specified in the EPOCH keyword.

3.2.4.4 Table 3-3 is broken into six logical blocks, each of which has a descriptive heading. These descriptive headings shall not be included in an OPM, unless they appear in a properly formatted COMMENT statement.

3.2.4.5 If the solar radiation coefficient, C_R , is set to zero, no solar radiation pressure shall be considered.

3.2.4.6 If the atmospheric drag coefficient, C_D , is set to zero, no atmospheric drag shall be considered.

3.2.4.7 Parameters for thrust phases may be optionally given for the computation of the trajectory during or after maneuver execution (see [reference \[M-1\]ANNEX N, Reference \[N-1\]](#) for the simplified modeling of such maneuvers). For impulsive maneuvers, MAN_DURATION must be set to zero. MAN_DELTA_MASS may be used for both finite and impulsive maneuvers; the value must be a negative number.

3.2.4.8 Multiple sets of maneuver parameters may appear. For each maneuver, all the maneuver parameters shall be repeated in the order shown in table 3-3.

3.2.4.9 If the OPM contains a maneuver definition, the Spacecraft Parameters section must be included.

3.2.4.10 Values in the covariance matrix shall be expressed in the applicable reference frame (COV_REF_FRAME keyword), and shall be presented sequentially from upper left [1,1] to lower right [6,6], lower triangular form, row by row left to right. Variance and covariance values shall be expressed in standard double precision as related in 7.5. This logical block of the OPM may be useful for risk assessment and establishing maneuver and mission margins. The intent is to provide causal connections between output orbit data and both physical hypotheses and measurement uncertainties. These causal relationships guide operators' corrective actions and mitigations.

3.2.4.11 A section of User Defined Parameters ~~may be provided if necessary~~ is allowed. In principle, this provides flexibility, but also introduces complexity, non-standardization, potential ambiguity, and potential processing errors. Accordingly, if used, the keywords and their meanings must be described in an ICD. User Defined Parameters, if included ~~in an OPM~~, should be used as sparingly as possible; their use is not encouraged.

~~3.3 — OPM EXAMPLES AND SUPPLEMENTARY INFORMATION~~

~~Example OPMs and associated supplementary (non-normative) information are provided in Annex D.~~

4 ORBIT MEAN-ELEMENTS MESSAGE (OMM)

4.1 GENERAL

4.1.1 Orbit information may be exchanged between two participants by sending an orbital state based on mean Keplerian elements (see ~~reference [M-1]~~ANNEX N, Reference [N-1]) for a specified epoch using an Orbit Mean-Elements Message (OMM). The message recipient must use appropriate orbit propagator algorithms in order to correctly propagate the OMM state to compute the orbit at other desired epochs.

4.1.2 The OMM is intended to allow replication of the data content of an existing TLE in a CCSDS standard format, but the message can also accommodate other implementations of mean elements. All essential fields of the 'de facto standard' TLE are included in the OMM in a style that is consistent with that of the other ODMs (i.e., the OPM and OEM). From the fields in the OMM, it is possible to generate a TLE (see ~~reference [M-2]~~ANNEX N, Reference [N-2]). Programs that convert OMMs to TLEs must be aware of the structural requirements of the TLE, including the checksum algorithm and the formatting requirements for the values in the TLE. The checksum and formatting requirements of the TLE do not apply to the values in an OMM.

4.1.3 If participants wish to exchange osculating element information, then the Orbit Parameter Message (OPM) or the Orbit Comprehensive Message (OCM) should be the selected message type. (See sections 3 and 6.)

4.1.4 The use of the OMM is best applicable under the following conditions:

- a) an orbit propagator consistent with the models used to develop the orbit data should be run at the receiver's site;
- b) the receiver's modeling of gravitational forces, solar radiation pressure, atmospheric drag, etc. (~~see reference [M-1]~~(see ANNEX N, Reference [N-1])), should fulfill accuracy requirements established between the exchange partners.

4.1.5 The OMM shall be a plain text file consisting of orbit data for a single object.

NOTE: A sequence of OMMs for either a single object or for multiple objects may be aggregated into a single Navigation Data Message (NDM) XML file as shown in ANNEX H.

4.1.6 The OMM file-naming scheme should be mutually agreed ~~to on a case-by-case basis between the message exchange partners, and should be documented in an ICD.~~

4.1.6.1.7 The method of exchanging OMMs should be ~~decided on a case-by-case basis by the mutually agreed between message exchange partners and documented in an ICD.~~

NOTE—1: Detailed syntax rules for the OMM are specified in section 77.

NOTE 2: Example OMMs and associated supplementary (non-normative) information are provided in ANNEX E.

4.2 OMM CONTENT/STRUCTURE

4.2.1 GENERAL

The OMM shall be represented as a combination of the following:

- a) a header;
- b) metadata (data about data);
- c) data with optional User-Defined Parameters; and
- d) optional comments (explanatory information).

4.2.2 OMM HEADER

4.2.2.1 Table 4-1 specifies for each header item:

- a) the keyword to be used;
- b) a short description of the item;
- c) examples of allowed values; and
- d) whether the item is Mandatory (M), Optional (O), or Conditional (C). Conditional means that if the delineated conditions are met, the item is mandatory or optional.

4.2.2.2 Only those keywords shown in table 4-1 shall be used in an OMM header.

Table 4-1: OMM Header

Keyword	Description	Examples of Values	Mandatory <u>M/O/C</u>
CCSDS_OMM_VERS	Format version in the form of 'x.y', where 'y' is incremented for corrections and minor changes, and 'x' is incremented for major changes.	3.0	Yes <u>M</u>
COMMENT	Comments (allowed in the OMM Header only immediately after the OMM version number). (See 7.7 for formatting rules.)	This is a comment	No <u>O</u>
CREATION_DATE	File creation date/time in UTC. (For format specification, see 7.5.10.)	2001-11-06T11:17:33 2002-204T15:56:23Z	Yes <u>M</u>
ORIGINATOR	Creating agency or operator. Select from the accepted set of values indicated in ANNEX B, Section B1.	CNES, ESOC, GSFC, GSOC, JPL, JAXA, INTELSAT, USAF, INMARSAT	Yes <u>M</u>

MESSAGE_ID	ID that uniquely identifies a message from a given originator. The format and content of the message identifier value are at the discretion of the originator.	OMM 201113719185 ABC-12_34	No <u>O</u>
------------	--	-------------------------------	------------------------

4.2.3 OMM METADATA

4.2.3.1 Table 4-2 specifies for each metadata item:

- a) the keyword to be used;
- b) a short description of the item;
- c) examples of allowed values; and
- d) whether the item is Mandatory (M), Optional (O), or Conditional (C). Conditional means that if the delineated conditions are met, the item is mandatory-or-optional.

4.2.3.2 Only those keywords shown in table 4-2 shall be used in OMM metadata.

NOTE – For some keywords (OBJECT_NAME and OBJECT_ID there are no definitive lists of authorized values maintained by a control authority; the references listed in 1.76 are the best known sources for authorized values to date.

Table 4-2: OMM Metadata

Keyword	Description	Examples of Values	Mandatory <u>M/O</u> <u>/C</u>
COMMENT	Comments (allowed at the beginning of the OMM Metadata). (See 7.7 for formatting rules.)	This is a comment	No <u>O</u>
OBJECT_NAME	Spacecraft name for which the orbit state is provided. There is no CCSDS-based restriction on the value for this keyword, but it is recommended to use names from the UN Office of Outer Space Affairs designator index (reference 2.1.1.3), which include Object name and international designator of the participant.	TelKom 2 Spaceway 2 INMARSAT 4-F2	Yes <u>M</u>

CCSDS PROPOSED STANDARD FOR ORBIT DATA MESSAGES

Keyword	Description	Examples of Values	Mandatory M/O/C
OBJECT_ID	Object identifier of the object for which the orbit state is provided. There is no CCSDS-based restriction on the value for this keyword, but values should be the international spacecraft designator as published in the UN Office of Outer Space Affairs designator index (reference (2)-3). Recommended values have the format YYYY-NNNP{PP}, where: YYYY = Year of launch. NNN = Three-digit serial number of launch in year YYYY (with leading zeros). P{PP} = At least one capital letter for the identification of the part brought into space by the launch. In cases where the asset is not listed in the bulletin, or reference 3 , the UN Office of Outer Space Affairs designator index format is not used, or the content cannot be disclosed , the value should be provided in an ICD. set to UNKNOWN .	2005-046A 2005-046B 2003-022A	Yes M
CENTER_NAME	Origin of the STM-OMM reference frame , which shall be a natural solar system body (planets, asteroids, comets, and natural satellites), including any planet barycenter or the solar system barycenter. Natural bodies shall be selected from the accepted set of values indicated in ANNEX B, Section B2.	EARTH MARS MOON	Yes M
REF_FRAME	Name of the reference frame in which the Keplerian element data are given. Select from the accepted set of values indicated in ANNEX B, Section B4. Note: NORAD Two Line Element Sets and corresponding SGP orbit propagator ephemeris output outputs are explicitly defined to be in the True Equator Mean Equinox of Date (TEME of Date) reference frame. Therefore, TEME of date shall be used for OMMs based on NORAD Two Line Element sets, rather than the almost imperceptibly different TEME of Epoch (see reference [M-2] or [M-3] for further details): ANNEX N, Reference [N-2] or [N-3] for further details).	TEME TEMEOFDATE J2000	Yes M
REF_FRAME_EPOCH	Epoch of reference frame, if not intrinsic to the definition of the reference frame. (See 7.5.10 for formatting rules.)	2001-11-06T11:17:33 2002-204T15:56:23Z	Yes O
TIME_SYSTEM	Time system used for the orbit state and covariance matrix. Select from the accepted set of values indicated in ANNEX B, Section B3.	UTC	Yes M
MEAN_ELEMENT_THEORY	Description of the Mean Element Theory. Indicates the proper method to employ to propagate the state.	SGP4 DSST USM	Yes M

4.2.4 OMM DATA

4.2.4.1 Table 4-3 provides an overview of the five logical blocks in the OMM Data section (Mean Keplerian Elements, Spacecraft Parameters, TLE Related Parameters, Position/Velocity Covariance Matrix, and User Defined Parameters), and specifies for each data item:

- a) the keyword to be used;
- b) a short description of the item;
- c) the units to be used;
- d) whether the item is Mandatory (M), Optional (O), or Conditional (C). Conditional means that if the delineated conditions are met, the item is mandatory or optional.

4.2.4.2 Only those keywords shown in table 4-3 shall be used in OMM data.

NOTE – Requirements relating to the keywords in table 4-3 appear after the table.

Table 4-3: OMM Data

Keyword	Description	Units	Mandatory M/O/C
Mean Keplerian Elements in the Specified Reference Frame			
COMMENT	(See 7.7 for formatting rules.)	n/a	NoO
EPOCH	Epoch of Mean Keplerian elements. (See 7.5.10 for formatting rules.)	n/a	YesM
SEMI_MAJOR_AXIS or MEAN_MOTION	Semi-major axis in kilometers (preferred), or, if MEAN_ELEMENT_THEORY = SGP/SGP4, the Keplerian Mean motion in revolutions per day	km rev/day	YesM
ECCENTRICITY	Eccentricity	n/a	YesM
INCLINATION	Inclination	deg	YesM
RA_OF_ASC_NODE	Right ascension of ascending node	deg	YesM
ARG_OF_PERICENTER	Argument of pericenter	deg	YesM
MEAN_ANOMALY	Mean anomaly	deg	YesM
GM	Gravitational Coefficient (Gravitational Constant x Central Mass)	km**3/s**2	NoO
Spacecraft Parameters			
COMMENT	(See 7.7 for formatting rules.)	n/a	NoO
MASS	Spacecraft Mass	kg	NoO
SOLAR_RAD_AREA	Solar Radiation Pressure Area (A _R)	m**2	NoO
SOLAR_RAD_COEFF	Solar Radiation Pressure Coefficient (C _R)	n/a	NoO
DRAG_AREA	Drag Area (A _D)	m**2	NoO
DRAG_COEFF	Drag Coefficient (C _D)	n/a	NoO
TLE Related Parameters -(This section is only required if MEAN_ELEMENT_THEORY=SGP/SGP4)			
COMMENT	(See 7.7 for formatting rules.)	n/a	NoO
EPHEMERIS_TYPE	Default value = 0. (See 4.2.4.7.)	n/a	NoO

CCSDS PROPOSED STANDARD FOR ORBIT DATA MESSAGES

Keyword	Description	Units	Mandatory M/O/C
CLASSIFICATION_TYPE	Default value = U. (See 4.2.4.7.)	n/a	<u>No</u> <u>O</u>
NORAD_CAT_ID	NORAD Catalog Number ('Satellite Number') an integer of up to nine digits. This keyword is only required if MEAN_ELEMENT_THEORY=SGP/SGP4.	n/a	<u>No</u> <u>O</u>
ELEMENT_SET_NO	Element set number for this satellite. Normally incremented sequentially, but may be out of sync if it is generated from a backup source. Used to distinguish different TLEs, and therefore only meaningful if TLE-based data is being exchanged (i.e., MEAN_ELEMENT_THEORY = SGP/SGP4).	n/a	<u>No</u> <u>O</u>
REV_AT_EPOCH	Revolution Number	n/a	<u>No</u> <u>O</u>
BSTAR	SGP/SGP4 drag-like coefficient (in units 1/[Earth radii]). Only required if MEAN_ELEMENT_THEORY=SGP/SGP4	1/ER	<u>No</u> <u>O</u>
MEAN_MOTION_DOT	First Time Derivative of the Mean Motion (only required if MEAN_ELEMENT_THEORY = SGP)	rev/day**2	<u>No</u> <u>O</u>
MEAN_MOTION_DDOT	Second Time Derivative of Mean Motion (only required if MEAN_ELEMENT_THEORY = SGP)	rev/day**3	<u>No</u> <u>O</u>
Position/Velocity Covariance Matrix (6x6 Lower Triangular Form. None or all parameters of the matrix must be given. COV_REF_FRAME may be omitted if it is the same as the REF_FRAME.)			
COMMENT	(See 7.7 for formatting rules.)	n/a	<u>No</u> <u>O</u>
COV_REF_FRAME	Reference frame in which the covariance data are given. Select from the accepted set of values indicated in ANNEX B, Sections B4 and B5.	n/a	<u>No</u> <u>C</u>
CX_X	Covariance matrix [1,1]	km**2	<u>No</u> <u>C</u>
CY_X	Covariance matrix [2,1]	km**2	<u>No</u> <u>C</u>
CY_Y	Covariance matrix [2,2]	km**2	<u>No</u> <u>C</u>
CZ_X	Covariance matrix [3,1]	km**2	<u>No</u> <u>C</u>
CZ_Y	Covariance matrix [3,2]	km**2	<u>No</u> <u>C</u>
CZ_Z	Covariance matrix [3,3]	km**2	<u>No</u> <u>C</u>
CX_DOT_X	Covariance matrix [4,1]	km**2/s	<u>No</u> <u>C</u>
CX_DOT_Y	Covariance matrix [4,2]	km**2/s	<u>No</u> <u>C</u>
CX_DOT_Z	Covariance matrix [4,3]	km**2/s	<u>No</u> <u>C</u>
CX_DOT_X_DOT	Covariance matrix [4,4]	km**2/s**2	<u>No</u> <u>C</u>
CY_DOT_X	Covariance matrix [5,1]	km**2/s	<u>No</u> <u>C</u>
CY_DOT_Y	Covariance matrix [5,2]	km**2/s	<u>No</u> <u>C</u>
CY_DOT_Z	Covariance matrix [5,3]	km**2/s	<u>No</u> <u>C</u>
CY_DOT_X_DOT	Covariance matrix [5,4]	km**2/s**2	<u>No</u> <u>C</u>
CY_DOT_Y_DOT	Covariance matrix [5,5]	km**2/s**2	<u>No</u> <u>C</u>
CZ_DOT_X	Covariance matrix [6,1]	km**2/s	<u>No</u> <u>C</u>
CZ_DOT_Y	Covariance matrix [6,2]	km**2/s	<u>No</u> <u>C</u>
CZ_DOT_Z	Covariance matrix [6,3]	km**2/s	<u>No</u> <u>C</u>
CZ_DOT_X_DOT	Covariance matrix [6,4]	km**2/s**2	<u>No</u> <u>C</u>
CZ_DOT_Y_DOT	Covariance matrix [6,5]	km**2/s**2	<u>No</u> <u>C</u>
CZ_DOT_Z_DOT	Covariance matrix [6,6]	km**2/s**2	<u>No</u> <u>C</u>
User Defined Parameters (all parameters in this section must be described in an ICD).			

Keyword	Description	Units	Mandatory M/O/C
USER_DEFINED_x	User defined parameter, where 'x' is replaced by a variable length user specified character string. Any number of user defined parameters may be included, if necessary to provide essential information that cannot be conveyed in COMMENT statements. Example: USER_DEFINED_EARTH_MODEL = WGS-84	n/a	No

4.2.4.3 All values in the OMM are 'at epoch', i.e., the value of the parameter at the time specified in the EPOCH keyword.

4.2.4.4 Table 4-3 is broken into five logical blocks, each of which has a descriptive heading. These descriptive headings shall not be included in an OMM, unless they appear in a properly formatted COMMENT statement.

4.2.4.5 Values in the covariance matrix shall be expressed in the applicable reference frame (COV_REF_FRAME keyword if used, or REF_FRAME keyword if not), and shall be presented sequentially from upper left [1,1] to lower right [6,6], lower triangular form, row by row left to right. Variance and covariance values shall be expressed in standard double precision as related in 7.5. This logical block of the OMM may be useful for risk assessment and establishing maneuver and mission margins.

4.2.4.6 For operations in Earth orbit with a TLE-based OMM, some special conventions must be observed, as follows:

- The value associated with the CENTER_NAME keyword shall be 'EARTH'.
- The value associated with the REF_FRAME keyword shall be 'TEMEOFDATE' (see ANNEX B, Section B4).
- The value associated with the TIME_SYSTEM keyword shall be 'UTC'.
- The format of the OBJECT_NAME and OBJECT_ID keywords shall be that of the UN Office of Outer Space Affairs designator index (reference ~~{2}~~:3).
- The MEAN_MOTION keyword must be used instead of SEMI_MAJOR_AXIS.

4.2.4.7 For those who wish to use the OMM to represent a TLE, there are a number of considerations that apply with respect to precision of angle representation, use of certain fields by the propagator, reference frame, etc. Some sources suggest the coding for the EPHEMERIS_TYPE keyword: 1=SGP, 2=SGP4, 3=SDP4, 4=SGP8, 5=SDP8. Some sources suggest the following coding for the CLASSIFICATION_TYPE keyword: U=unclassified, S=secret. (For further information see ~~references [M-2]~~ANNEX N, Reference [N-2] and ~~[M-3]~~[N-3])

4.2.4.8 Maneuvers are not accommodated in the OMM. Users of the OMM who wish to model maneuvers may use several OMM files to describe the orbit at applicable epochs.

4.2.4.9 A section of User Defined Parameters is allowed. In principle, this provides flexibility, but also introduces complexity, non-standardization, potential ambiguity, and potential processing errors. Accordingly, if used, the keywords and their meanings must be described in an ICD. User Defined Parameters, if included ~~in an OMM~~, should be used as sparingly as possible; their use is not encouraged.

~~4.3 OMM EXAMPLES AND SUPPLEMENTARY INFORMATION~~

~~Example OMMs and associated supplementary (non-normative) information are provided in Annex E.~~

5 ORBIT EPHEMERIS MESSAGE (OEM)

5.1 GENERAL

5.1.1 Orbit information may be exchanged between two participants by sending an ephemeris in the form of a series of state vectors (Cartesian vectors providing position and velocity, and optionally accelerations) using an Orbit Ephemeris Message (OEM). The message recipient must have a means of interpolating across these state vectors to obtain the state at an arbitrary time contained within the span of the ephemeris.

5.1.2 The OEM may be used for assessing mutual physical or electromagnetic interference among Earth-orbiting spacecraft, developing collaborative maneuvers, and representing the orbits of active satellites, inactive man-made objects, near-Earth debris fragments, etc. The OEM reflects the dynamic modeling of any users' approach to conservative and non-conservative phenomena.

5.1.3 The OEM shall be a plain text file consisting of orbit data for a single object.

NOTE: A sequence of OEMs for either a single object or for multiple objects may be aggregated into a single Navigation Data Message (NDM) XML file as shown in ANNEX H.

5.1.4 The OEM file-naming scheme should be mutually agreed ~~to on a case-by-case basis between the participants, typically using an ICD. message exchange partners.~~

~~5.1.4~~**5.1.5** The method of exchanging OEMs should be ~~decided on a case-by-case basis by the participants and documented in an ICD~~mutually agreed between message exchange partners.

NOTE—1: Detailed syntax rules for the OEM are specified in section ~~7~~7.

NOTE 2: Example OEMs and associated supplementary (non-normative) information are provided in ANNEX F.

5.2 OEM CONTENT/STRUCTURE

5.2.1 GENERAL

5.2.1.1 The OEM shall be represented as a combination of the following:

- a) a header;
- b) metadata (data about data);
- c) ephemeris data;
- d) optional covariance matrix data; and

- e) optional comments (explanatory information).

5.2.1.2 OEM files must have a set of minimum required sections; some may be repeated. Table 5-1 outlines the contents of an OEM.

Table 5-1: OEM File Layout Specifications

Required Sections	Header Metadata Ephemeris Data (Appropriate comments should also be included, although they are not required.)
Allowable Repetitions of Sections	Covariance Matrix (optional) Metadata Ephemeris Data Covariance Matrix (optional) Metadata Ephemeris Data Covariance Matrix (optional) Metadata Ephemeris Data Covariance Matrix (optional) ...etc. (Appropriate comments should also be included.)

5.2.2 OEM HEADER

5.2.2.1 The OEM header assignments are shown in table 5-2, which specifies for each item:

- a) the keyword to be used;
- b) a short description of the item;
- c) examples of allowed values; and
- d) whether the item is Mandatory (M), Optional (O), or Conditional (C). Conditional means that if the delineated conditions are met, the item is mandatory~~or optional~~.

5.2.2.2 Only those keywords shown in table 5-2 shall be used in an OEM header.

Table 5-2: OEM Header

Keyword	Description	Examples of Values	Mandatory M/O/C
CCSDS_OEM_VERS	Format version in the form of 'x.y', where 'y' is incremented for corrections and minor changes, and 'x' is incremented for major changes.	3.0	Yes <u>M</u>
COMMENT	Comments (allowed in the OEM Header only immediately after the OEM version number). (See 7.7 for formatting rules.)	COMMENT This is a comment	No <u>O</u>
CREATION_DATE	File creation date and time in UTC. (For format specification, see 7.5.10.)	2001-11-06T11:17:33 2002-204T15:56:23	Yes <u>M</u>
ORIGINATOR	Creating agency or operator. Select from the accepted set of values indicated in ANNEX B, Section B1.	CNES, ESOC, GSFC, GSOC, JPL, JAXA, INTELSAT, USAF, INMARSAT	Yes <u>M</u>
MESSAGE_ID	ID that uniquely identifies a message from a given originator. The format and content of the message identifier value are at the discretion of the originator.	OEM 201113719185 ABC-12_34	No <u>O</u>

5.2.3 OEM METADATA

5.2.3.1 The OEM metadata assignments are shown in table 5-3, which specifies for each item:

- a) the keyword to be used;
- b) a short description of the item;
- c) examples of allowed values; and
- d) whether the item is Mandatory (M), Optional (O), or Conditional (C). Conditional means that if the delineated conditions are met, the item is mandatory-or-optional.

5.2.3.2 Only those keywords shown in table 5-3 shall be used in OEM metadata.

NOTE – For some keywords (OBJECT_NAME and OBJECT_ID) there are no definitive lists of authorized values maintained by a control authority; the references listed in 1.7 are the best known sources for authorized values to date. For the TIME_SYSTEM and REF_FRAME keywords, see ANNEX B, Section B3 and Section B4 respectively, for guidance and a link to the approved set of values.

5.2.3.3 A single metadata group shall precede each ephemeris data block. Multiple occurrences of a metadata group followed by an ephemeris data block may be used. Before each metadata group the string 'META_START' shall appear on a separate line and after each metadata group (and before the associated ephemeris data block) the string 'META_STOP' shall appear on a separate line.

Table 5-3: OEM Metadata

Keyword	Description	Examples of Values	Mandatory M/O/C
META_START	The OEM message contains metadata, ephemeris data, and covariance data; this keyword is used to delineate the start of a metadata block within the message (metadata are provided in a block, surrounded by 'META_START' and 'META_STOP' markers to facilitate file parsing). This keyword must appear on a line by itself.	n/a	Yes M
COMMENT	Comments allowed only immediately after the META_START keyword. (See 7.7 for formatting rules.)	COMMENT This is a comment.	No O
OBJECT_NAME	The name of the object for which the ephemeris is provided. There is no CCSDS-based restriction on the value for this keyword, but it is recommended to use names from the UN Office of Outer Space Affairs designator index (reference 2 3), which include Object name and international designator of the participant.	EUTELSAT W1 MARS PATHFINDER STS 106 NEAR	YesM
OBJECT_ID	Object identifier of the object for which the ephemeris is provided. There is no CCSDS-based restriction on the value for this keyword, but values should be the international spacecraft designator as published in the UN Office of Outer Space Affairs designator index (reference 2 3). Recommended values have the format YYYY-NNNP{PP}, where: YYYY = Year of launch. NNN = Three-digit serial number of launch in year YYYY (with leading zeros). P{PP} = At least one capital letter for the identification of the part brought into space by the launch. In cases where the asset is not listed in reference 2 , or 3, the UN Office of Outer Space Affairs designator index format is not used, or the content cannot be disclosed , the value should be provided in an ICD set to <u>UNKNOWN</u> .	2000-052A 1996-068A 2000-053A 1996-008A	YesM

CCSDS PROPOSED STANDARD FOR ORBIT DATA MESSAGES

Keyword	Description	Examples of Values	Mandatory M/O/C
CENTER_NAME	<p>Origin of the STM-OEM reference frame, which may be a natural solar system body (planets, asteroids, comets, and natural satellites), including any planet barycenter or the solar system barycenter, or another reference frame center (such as a spacecraft, ground station, formation flying reference “chief” spacecraft, etc.).</p> <p>Natural bodies shall be selected from the accepted set of values indicated in ANNEX B, Section B2.</p> <p>For spacecraft, it is recommended to use either the Object name OBJECT_ID or international designator of the participant as catalogued in the UN Office of Outer Space Affairs designator index (reference [2]). Alternately, the OBJECT_DESIGNATOR may be used.</p> <p>For other reference frame origins, this field is a free text descriptor which can draw upon ground station name, etc.3).</p>	<p>EARTH EARTH BARYCENTER MOON SOLAR SYSTEM BARYCENTER SUN JUPITER BARYCENTER STS 106 EROS</p>	Yes <u>M</u> <u>C</u>
REF_FRAME	Reference frame in which the ephemeris data are given. Select from the accepted set of values indicated in ANNEX B, Section B4.	<p>ICRF3 ITRF1993 ITRF1997 ITRF2000 ITRFyyyy (template for future versions) TOD (True Equator and Equinox of Date) J2000 (Earth Mean Equator and Equinox of J2000) TDR (true of date rotating) GRC (Greenwich rotating coordinate frame, another name for TDR)</p>	Yes <u>M</u>
REF_FRAME_EPOCH	Epoch of reference frame, if not intrinsic to the definition of the reference frame. (See 7.5.10 for formatting rules.)	<p>2001-11-06T11:17:33 2002-204T15:56:23Z</p>	No <u>O</u>
TIME_SYSTEM	Time system used for metadata, ephemeris and covariance data (also see table 3-3). Select from the accepted set of values indicated in ANNEX B, Section B3.	UTC, TAI, TT, GPS, TDB, TCB	Yes <u>M</u>
START_TIME	Start of TOTAL time span covered by ephemeris data and covariance data immediately following this metadata block. (For format specification, see 7.5.10.)	<p>1996-12-18T14:28:15.1172 1996-277T07:22:54</p>	Yes <u>M</u>

CCSDS PROPOSED STANDARD FOR ORBIT DATA MESSAGES

Keyword	Description	Examples of Values	Mandatory M/O/ C
<p>USEABLE_START_TIME</p> <p>USEABLE_STOP_TIME</p>	<p>Optional start and end of USEABLE time span covered by ephemeris data immediately following this metadata block. To allow for proper interpolation near the ends of the ephemeris data block it may be necessary, depending upon the interpolation method to be used, to utilize these keywords with values within the time span covered by the ephemeris data records as delimited by the START/STOP_TIME time tags. (For format specification, see For format specification, see 7.5.10.) These keywords are optional items, and thus may not be necessary, depending on the recommended interpolation method. However, it is recommended to use the USEABLE_START_TIME and USEABLE_STOP_TIME capability in all cases.</p> <p><u>These optional keywords allow the message creator to introduce fictitious (but numerically smooth) data nodes outside of the actual data time history to support interpolation methods requiring more than two nodes (e.g., pure higher-order Lagrange interpolation methods). The use of these keywords and introduction of fictitious node points are optional and may not be necessary.</u></p> <p>The USEABLE_START_TIME time tag at a new block of ephemeris data must be greater than or equal to the USEABLE_STOP_TIME time tag of the previous block.</p>	<p>1996-12-18T14:28:15.1172</p> <p>1996-277T07:22:54</p>	<p>No Q</p>
<p>STOP_TIME</p>	<p>End of TOTAL time span covered by ephemeris data and covariance data immediately following this metadata block. (For format specification, see 7.5.10.)</p>	<p>1996-12-18T14:28:15.1172</p> <p>1996-277T07:22:54</p>	<p>Yes M</p>
<p>INTERPOLATION</p>	<p>This keyword may be used to specify the recommended interpolation method for ephemeris data in the immediately following set of ephemeris lines. PROPAGATE indicates that orbit propagation is the preferred method to obtain states at intermediate times, via either a midpoint-switching or endpoint switching approach.</p>	<p>HERMITE LINEAR LAGRANGE PROPAGATE</p>	<p>No Q</p>
<p>INTERPOLATION_DEGREE</p>	<p>Recommended interpolation degree for ephemeris data in the immediately following set of ephemeris lines. Must be an integer value. This keyword must be used if the 'INTERPOLATION' keyword is used and set to anything other than PROPAGATE.</p>	<p>5 1</p>	<p>No Q</p>

Keyword	Description	Examples of Values	Mandatory M/O/C
META_STOP	The OEM message contains metadata, ephemeris data, and covariance data; this keyword is used to delineate the end of a metadata block within the message (metadata are provided in a block, surrounded by 'META_START' and 'META_STOP' markers to facilitate file parsing). This keyword must appear on a line by itself.	n/a	Yes

5.2.4 OEM DATA: EPHEMERIS DATA LINES

5.2.4.1 Each set of ephemeris data, including the time tag, must be provided on a single line. The order in which data items are given shall be fixed: **Epoch, X, Y, Z, X_DOT, Y_DOT, Z_DOT, X_DDOT, Y_DDOT, Z_DDOT.**

5.2.4.2 The position and velocity terms shall be mandatory; acceleration terms may be provided.

5.2.4.3 At least one space character must be used to separate the items in each ephemeris data line.

5.2.4.4 Repeated time tags may occur in consecutive ephemeris data blocks if the STOP_TIME of the first ephemeris data block is greater than the START_TIME of the second ephemeris data block. Although the USEABLE_STOP_TIME and USEABLE_START_TIME of the consecutive ephemeris data blocks must not overlap (except for a possibly shared endpoint), the STOP_TIME of the first ephemeris data block may be greater than the START_TIME of the second ephemeris data block if the extra data is required for interpolation purposes.

5.2.4.5 The TIME_SYSTEM value must remain fixed within an OEM.

5.2.4.6 The occurrence of a second (or greater) metadata block after some ephemeris data indicates that interpolation using succeeding ephemeris data with ephemeris data occurring prior to that metadata block shall not be done. This method may be used for proper modeling of propulsive maneuvers or any other source of a discontinuity such as eclipse entry or exit.

5.2.4.7 Details about interpolation method should be specified using the INTERPOLATION and INTERPOLATION_DEGREE keywords within the OEM. All data blocks must contain a sufficient number of ephemeris data records to allow the recommended interpolation method to be carried out consistently throughout the OEM.

5.2.5 OEM DATA: COVARIANCE MATRIX LINES

5.2.5.1 A single covariance matrix data section may optionally follow each ephemeris data block.

5.2.5.2 If present, the covariance matrix data lines in the OEM are separated from the ephemeris data by means of two new keywords: ~~COV_START and COVARIANCE_STOP.~~ The 'COVARIANCE_START' and 'COVARIANCE_STOP'. The COVARIANCE_START keyword must appear before the first line of the covariance matrix data. The ~~'COVARIANCE_STOP'~~STOP keyword must appear after the last line of covariance data. Each of these keywords shall appear on a line by itself with no time tags or values.

5.2.5.3 The epoch of the navigation solution related to the covariance matrix must be provided via the 'EPOCH' keyword. The reference frame of the covariance matrix, if different from that of the states in the ephemeris, must be provided via the 'COV_REF_FRAME' keyword.

NOTE: COV_REF_FRAME must be specified for each covariance matrix block if it is not in the same frame as the ephemeris.

5.2.5.4 Each row of the 6x6 lower triangular covariance matrix must be provided on a single line. The order in which data items are given shall be fixed. The elements in each row of covariates shall be defined by the order in the ephemeris data line (i.e., X, Y, Z, X_DOT, Y_DOT, Z_DOT). The six rows of the covariance matrix contain from one to six numbers depending on what row of the matrix is being represented (first row has one element, second row has two, continuing in this fashion until the sixth row has six elements).

5.2.5.5 At least one space character must be used to separate the items in each covariance matrix data line.

5.2.5.6 Multiple covariance matrices may appear in the covariance matrix section; they may appear with any desired frequency (one for each navigation solution that makes up the overall ephemeris is recommended). The OEM may also contain propagated covariances, not just individual covariances associated with navigation solutions.

5.2.5.7 If there are multiple covariance matrices in the data section, they must be ordered by increasing time tag.

~~5.3 OEM EXAMPLES AND SUPPLEMENTARY INFORMATION~~

~~Example OEMs and associated supplementary (non-normative) information are provided in Annex F.~~

6 ORBIT COMPREHENSIVE MESSAGE (OCM)

6.1 GENERAL DESCRIPTION

6.1.1 Comprehensive orbit information may be exchanged between two participants by sending orbit data/content for one or more epochs using an Orbit Comprehensive Message (OCM). The OCM aggregates and extends OMM, OPM, and OEM content in a single hybrid message. The OCM simultaneously emphasizes flexibility and message conciseness by offering extensive optional standardized content while minimizing mandatory content.

6.1.2 The OCM shall be a plain text file consisting of orbit data for a single space object, or in the case of a parent/child satellite deployment scenario, a single parent object.

~~**6.1.3** The OCM file-naming scheme should be agreed to on a case-by-case basis between the exchange partners, and should be documented in an ICD. The method of exchanging OCMs should be decided on a case-by-case basis by the exchange partners.~~

NOTE: A sequence of OCMs for either a single object or for multiple objects may be aggregated into a single Navigation Data Message (NDM) XML file as shown in ANNEX H.

~~**6.1.4.6.1.3**~~ Orbit information may be exchanged between two or more participants by sending an ephemeris in the form of one or more time series of orbital states (selectable as orbital elements and/or Cartesian vectors providing position and optionally velocity and accelerations) using an Orbit Comprehensive Message (OCM). If orbital states are desired at arbitrary time(s) contained within the span of the ~~ephemeris~~provided orbit or covariance time histories, the message recipient must use a suitable interpolation method. For times outside of supplied orbit or covariance state time spans or if the step size between ~~orbit state~~time points is too large to support interpolation ~~[M-6],(ANNEX N, Reference [N-6])~~, optional perturbations parameters ~~can and~~ should be included in this message ~~and to allow~~ the message recipient ~~must to~~ use a suitably-compatible orbit and covariance propagator.

~~**6.1.5.6.1.4**~~ The OCM may be used for assessing mutual physical or electromagnetic interference among Earth-orbiting spacecraft, developing collaborative maneuvers, and representing the orbits of active satellites, inactive man-made objects, near-Earth debris fragments, etc. The OCM reflects the dynamic modeling of any users' approach to conservative and non-conservative phenomena.

~~**6.1.5** The OCM file-naming scheme should be mutually agreed between message exchange partners.~~

~~**6.1.6** The method of exchanging OCMs should be mutually agreed between message exchange partners.~~

NOTE— 1: Detailed syntax rules for the OCM are specified in section 7.

NOTE 2: Example OCMs and associated supplementary (non-normative) information are provided in ANNEX G.

6.2 OCM STRUCTURE AND OVERARCHING REQUIREMENTS

6.2.1 GENERAL STRUCTURE

The OCM shall be represented as the combination of the following elements, ordered as listed in Table 6-1. Note that while many of the sections are optional, at least one of the optional data sections must be provided. Elements are represented as being “mandatory” or “optional” by an M or O in the right-hand column.

Table 6-1: OCM File Layout and Ordering Specification

Section			Content	Status Mandatory? M/O/C	
<u>OCM Header</u>			A single header of the message.	<u>Yes</u> M	
<u>Segment</u>	<u>OCM Metadata</u>		A single metadata section (data about data).	<u>Yes</u> M	
	<u>Orbit Data</u>	<u>orbit data 1</u>	<u>metadata</u>	One or more orbit state time histories (consisting of one or more orbit states).	<u>Ne</u> O
			<u>data lines</u>		
		⋮			
		<u>orbit data n</u>	<u>metadata</u>		
		<u>data lines</u>			
<u>Space Object Physical Description</u>		<u>physical properties</u>		A single space object physical characteristics section . <u>section</u>	<u>Ne</u> O
<u>Covariance Data</u>		<u>covariance data 1</u>	<u>metadata</u>	One or more covariance time histories (each consisting of one or more covariance matrices).	<u>Ne</u> O
<u>State Transition Matrix Data</u>	<u>One or more state transition matrix time histories</u>	<u>Ne</u>	<u>data lines</u>		

	(each consisting of one or more state transition matrices).				
		⋮			
		<u>covariance data n</u>	<u>metadata</u>		
			<u>data lines</u>		
<u>Maneuver Data</u>		<u>maneuver data 1</u>	<u>metadata</u>	One or more maneuver specifications for either impulsive or finite burns or acceleration profiles.	<u>NeO</u>
			<u>data lines</u>		
		⋮			
		<u>maneuver data n</u>	<u>metadata</u>		
			<u>data lines</u>		
<u>Perturbations Parameters</u>		<u>perturbation parameters</u>		A single perturbations parameters section.	<u>NeO</u>
<u>Orbit Determination Data</u>		<u>orbit determination</u>		A single orbit determination data section.	<u>NeO</u>
		-user-defined parameters		One or more <u>A single</u> user-defined parameters sections <u>section</u> containing data and supplemental comments (explanatory information).	<u>NeO</u>

6.2.1 GENERAL REQUIREMENTS

The following requirements apply to all OCM sections and content:

6.2.1.1 The order of occurrence of OCM keywords shall be fixed as listed in the keyword value tables in the OCM section descriptions.

6.2.1.2 Within the tables of each OCM section, ~~note that keywords labeled as “each keyword is labeled as being Mandatory (M), Optional (O), or Conditional (C). An ‘M’ denotes mandatory” in the corresponding tables denotes those~~ keywords that must be included in this section if that particular data section is included. ~~If a keyword is labeled as mandatory and~~ Keywords that have a pre-defined (default) value are listed as ‘O’ (optional), because if the keyword is not provided, then the default value specified is defined in the corresponding table ~~entry~~, that value shall be used. A ‘C’ denote keywords that are mandatory if certain conditions are met, as delineated in the keyword description.

6.2.1.3 If the message creator does not have a value for a mandatory keyword, a value of “UNKNOWN” shall be used.

~~6.2.1.3~~**6.2.1.4** All time-tags may be specified by either a (signed) double precision relative time (e.g., 20157.26) measured in SI seconds with respect to the specified epoch time (~~e.g., the overarching default value~~ EPOCH_TZERO) or as an absolute time (e.g., 2018-11-13T11:13:20.5Z ~~as formatted in CCSDS Time String A or B format, as specified in Section 7.5.10) epoch time.~~).

6.2.1.5 Duplicate time tags shall not be permitted. Where one or more duplicate time tags are discovered, the former value(s) shall be supplanted by the single latter entry.

~~6.2.1.4~~**6.2.1.6** Within an OCM data block, all time-tags must adhere to either relative time, or absolute time, for the entirety of that data block. ~~It is not permitted to mix relative~~ Relative and absolute time shall not be used within the same data block.

~~6.2.1.5~~**6.2.1.7** Time tags of information within ordered sequences of OCM sections may be separated by uniform or non-uniform step size(s).

~~6.2.1.6~~**6.2.1.8** Time tags of one OCM section may or may not match those of another OCM section.

6.2.2 OCM HEADER

6.2.2.1 Table 6-2 specifies the keywords for each header item.

6.2.2.2 Only those keywords shown in table 6-2 shall be used in an OCM header.

6.2.2.3 The order of occurrence of these OCM header keywords shall be fixed as shown in table 6-2.

Table 6-2: OCM Header

Keyword	Description	Examples of Values	Mandatory M/O/C
CCSDS_OCM_VERS	Format version in the form of 'x.y', where 'y' is incremented for corrections and minor changes, and 'x' is incremented for major changes.	3.0	YesM
COMMENT	Comments (a contiguous set of one or more comment lines is allowed in the OCM Header only immediately after the OCM version number). (See 7.7 for formatting rules).	This is a comment	NoO
CREATION_DATE	File creation date/time in UTC. (For format specification, see 7.5.10).	2001-11-06T11:17:33 2002-204T15:56:23Z	YesM
ORIGINATOR	Creating agency or operator. Select from the accepted set of values indicated in ANNEX B, Section B1.	CNES, ESOC, GSFC, GSOC, JPL, JAXA, INTELSAT, USAF, INMARSAT	YesM
MESSAGE_ID	Free text field containing an ID that uniquely identifies a message from this message originator. The format and content of the message identifier value are at the discretion of the originator.	OCM 201113719185 ABC-12_34	NoO
CLASSIFICATION	User defined free text message classification/caveats of this OCM. It is recommended that selected values be pre-coordinated between exchanging entities by mutual agreement.	SBU "Operator proprietary data; secondary distribution not permitted"	No

6.2.3 OCM METADATA

6.2.3.1 Table 6-3 specifies the metadata keywords. Only those keywords shown in table 6-3 shall be used in OCM metadata.

6.2.3.2 The metadata section must begin with keyword META_START and end with keyword META_STOP.

6.2.3.3 At most, only one metadata section shall appear in the entire scope of an OCM.

6.2.3.4 The order of occurrence of these OCM metadata keywords shall be fixed as shown in ~~table~~Table 6-3.

NOTE—1: For some keywords (OBJECT_NAME, OBJECT_DESIGNATOR) there are no definitive lists of authorized values maintained by a control authority; the references listed in Section 1.7 are the best known sources for authorized values to date.

NOTE 2 – While specification of OBJECT_NAME, OBJECT_DESIGNATOR, and INTERNATIONAL_DESIGNATOR are individually optional, it is recommended that at least one of these three keywords ~~should~~ be supplied.

NOTE 3 – Metadata fields which are relied upon by the subsequent optional OCM message subtypes (orbit state time histories, maneuver data, etc.) are designated as such in the right-hand column of

~~Table 6-3.~~

Table 6-3.

Table 6-3: OCM Metadata

Keyword	Description	Default (if any)	Examples of Values	Mandatory/M/O/C	Any OCM sections relying upon this field?
META_START	Start of the metadata section.	n/a		n/a M	No
COMMENT	Comments (a contiguous set of one or more comment lines is allowed in the OCM Metadata section; see 7.7 for comment formatting rules).	n/a	This is a comment	No O	No
<u>CLASSIFICATION</u>	<u>User-defined free-text message classification/caveats of this OCM. It is recommended that selected values be pre-coordinated between exchanging entities by mutual agreement.</u>		<u>SBU</u> <u>“Operator-proprietary data; secondary distribution not permitted”</u>	<u>O</u>	
<u>OBJECT_NAME</u>	<u>Free text field containing the spacecraft name for the object. There is no CCSDS-based restriction on the value for this keyword, but it is recommended to use names from the UN Office of Outer Space Affairs designator index (reference 3), which include Object name and international designator of the participant.</u>		<u>SPOT-7</u> <u>ENVISAT</u> <u>IRIDIUM NEXT-8</u> <u>INTELSAT G-15</u> <u>UNKNOWN</u>	<u>O</u>	
<u>ALTERNATE_NAMES</u>	<u>Free text comma-delimited field containing alternate name(s) of this space object</u>		<u>SV08, IN8</u>	<u>O</u>	
<u>OBJECT_DESIGNATOR</u>	<u>Free text field specification of the unique satellite identification designator for the object, as reflected in the catalog whose name is “CATALOG NAME”. If the ID is not known (uncorrelated object), “UNKNOWN” may be used (or this keyword omitted).</u>		<u>22444</u> <u>18SPCS 18571</u> <u>2147483648_04ae[...]d8</u> <u>4c</u> <u>UNKNOWN</u>	<u>O</u>	

CCSDS PROPOSED STANDARD FOR ORBIT DATA MESSAGES

Keyword	Description	Default (if any)	Examples of Values	Mandatory M/ O/C	Any OCM sections relying upon this field?
<u>INTERNATIONAL_DESIGNATOR</u>	<p>Free text field containing an international designator for the object as assigned by the UN Committee on Space Research (COSPAR) and the US National Space Science Data Center (NSSDC). Such designator values have the following COSPAR format: <u>YYYY-NNNP{PP}</u>, where:</p> <p><u>YYYY</u> = Year of launch.</p> <p><u>NNN</u> = Three-digit serial number of launch in year YYYY (with leading zeros).</p> <p><u>P{PP}</u> = At least one capital letter for the identification of the part brought into space by the launch.</p> <p>In cases where the object has no international designator, the value <u>UNKNOWN</u> may be used.</p> <p>NOTE: The international designator was typically specified by "OBJECT ID" in the OPM, OMM, and OEM.</p>		<p><u>2000-052A</u> <u>1996-068A</u> <u>2000-053A</u> <u>1996-008A</u> <u>UNKNOWN</u></p>	<u>O</u>	
ORIGINATOR_POC	Free text field containing originator or programmatic Point-of-Contact (PoC) for OCM.	n/a	Mr. Rodgers	NeO	Ne
ORIGINATOR_POSITION	Free text field containing contact position of the originator PoC.	n/a	Flight Dynamics Mission Design Lead	NeO	Ne
ORIGINATOR_PHONE	Free text field containing originator PoC phone number.	n/a	+12345678901	NeO	Ne
ORIGINATOR_ADDRESS	Free text field containing originator PoC address information for OCM creator (suggest email, website, or physical address, etc.).	n/a	JOHN.DOE@SOMEWHERE.ORG	NeO	Ne
TECH--_ORG	Free text field containing the creating agency or operator (value should be drawn from the abbreviated "Organizations" name column of the SANA registry at https://www.sanaregistry.org/r/organizations).		NASA	NeO	Ne
TECH--_POC	Free text field containing technical Point-of-Contact (PoC) for OCM.		Maxwell Smart	NeO	Ne
TECH--_POSITION	Free text field containing contact position of the technical PoC.		Flight Dynamics Mission Design Lead	NeO	Ne
TECH--_PHONE	Free text field containing technical PoC phone number.		+49615130312	NeO	Ne
TECH_ADDRESS	Free text field containing technical PoC address information for OCM creator (suggest email, website, or physical address, etc.).		JOHN.DOE@SOMEWHERE.ORG	NeO	Ne

CCSDS PROPOSED STANDARD FOR ORBIT DATA MESSAGES

Keyword	Description	Default (if any)	Examples of Values	Mandatory/M/O/C	Any OCM sections relying upon this field?
PREVIOUS_MESSAGE_ID	Free text field containing an ID that uniquely identifies the previous message from this message originator for this particular space object. The format and content of the message identifier value are at the discretion of the originator. NOTE: One can may provide the previous message ID without supplying the PREVIOUS_MESSAGE_EPOCH, and vice versa.		OCM 201113719184 ABC-12_33	NoO	No
NEXT_MESSAGE_ID	Free text field containing an ID that uniquely identifies the next message from this message originator for this particular space object. The format and content of the message identifier value are at the discretion of the originator. NOTE: One can may provide the next message ID without supplying the NEXT_MESSAGE_EPOCH, and vice versa.		OCM 201113719186 ABC-12_35	NoO	No
ATT ADM_MSG_LINK	Free text field containing a unique identifier of Attitude Data Message(s) that are linked (relevant) to this Orbit Data Message.		ADM_MSG_35132.txt ATT ADM_ID_0572	NoO	No
CDM_MSG_LINK	Free text field containing a unique identifier of Conjunction Data Message(s) that are linked (relevant) to this Orbit Data Message.		CDM_MSG_35132.txt CDM_ID_8257	NoO	No
PRM_MSG_LINK	Free text field containing a unique identifier of Pointing Request Message(s) that are linked (relevant) to this Orbit Data Message.		PRM_MSG_35132.txt PRM_ID_6897	NoO	No
RDM_MSG_LINK	Free text field containing a unique identifier of Reentry Data Message(s) that are linked (relevant) to this Orbit Data Message.		RDM_MSG_35132.txt RDM_ID_1839	NoO	No
TDM MSG_LINK	Free text field containing a unique identifier of Tracking Data Message(s) that are linked (relevant) to this Orbit Data Message		TDM MSG_35132.txt TDM ID_8354	No	No

CCSDS PROPOSED STANDARD FOR ORBIT DATA MESSAGES

Keyword	Description	Default (if any)	Examples of Values	Mandatory/M/O/C	Any OCM sections relying upon this field?
OBJECT_NAME	Free text field containing the spacecraft name for the object. There is no CCSDS-based restriction on the value for this keyword, but it is recommended to use names from the UN Office of Outer Space Affairs designator index (reference [2]), which include Object name and international designator of the participant.		SPOT ENVISAT IRIDIUM INTELSAT UNKNOWN	No	No
INTERNATIONAL_DESIGNATOR	Free text field containing an international designator for the object as assigned by the UN Committee on Space Research (COSPAR) and the US National Space Science Data Center (NSSDC). Such designator values have the following COSPAR format: YYYY-NNNP{PP}, where: YYYY — = Year of launch. NNN — = Three digit serial number of launch in year YYYY (with leading zeros). P{PP} — = At least one capital letter for the identification of the part brought into space by the launch. In cases where the object has no international designator, the value UNKNOWN may be used. NOTE: The international designator is stored in OBJECT_ID in the OPM, OMM and OEM.		2000-052A 1996-068A 2000-053A 1996-008A UNKNOWN	No	No
CATALOG_NAME	Free text field specification of containing the satellite catalog source (or source agency or operator, value to be drawn from the abbreviated "Organizations" name column of the SANA registry at https://www.sanaregistry.org/r/organizations) from which the international designator and catalog ID were obtained).	CSPOC	CSPOC RFSA ESA COMSPOC N/A	No O	No
OBJECT_DESIGNATOR	Free text field specification of the unique satellite identification designator for the object. It may be useful to provide the control authority/source of this ID as well (e.g., 18SPCS, ISON, independent key ID). If the ID is not known (uncorrelated object), "UNKNOWN" may be used.		22444 18SPCS-18571 2147483648-04ae[...] 4e UNKNOWN N/A	No	No
OPERATOR	Free text field containing the operator of the space object.		INTELSAT	No O	No

CCSDS PROPOSED STANDARD FOR ORBIT DATA MESSAGES

Keyword	Description	Default (if any)	Examples of Values	Mandatory M/ O/C	Any OCM sections relying upon this field?
OWNER	Free text field containing the owner of the space object.		SIRIUS	No <u>O</u>	No
<u>COUNTRY</u>	<u>Free text field containing the name of the country, country code, or country abbreviation where the space object owner is based.</u>		<u>US</u> <u>SPAIN</u>	<u>O</u>	
CONSTELLATION	Free text field containing the name of the constellation to which this space object belongs.		SPIRE	No <u>O</u>	No
<u>LIFETIME</u>	<u>Estimated remaining orbit lifetime this space object measured in days from EPOCH_TZERO.</u>		<u>22.0</u>	No	No
OBJECT_TYPE	Specification of the type of object. Select from the accepted set of values indicated in ANNEX B, Section B11.		<u>PAYLOAD</u> <u>ROCKET BODY</u> <u>DEBRIS</u> <u>UNKNOWN</u> <u>OTHERPL</u> <u>RB</u> <u>RD</u>	No <u>O</u>	No
OPS_STATUS	Specification of the operational status of the space object. Select from the accepted set of values indicated in ANNEX B, Section B12.		OPERATIONAL	No <u>O</u>	No
<u>ORBIT_TYPECATEGORY</u>	Specification of the type of orbit. Select from the accepted set of values indicated in ANNEX B, Section B14.		EGO LEO	No <u>O</u>	No
OCM_DATA_ELEMENTS	Free text field containing a comma-delimited list of elements of information data blocks included in this message.		ORBIT, PHYSICAL DESCRIPTION, COVARIANCE, <u>STM</u> , MANEUVER, PERTURBATIONS, OD, USER	No <u>O</u>	No
TIME_SYSTEM	Time system <u>in which for all time stamps including EPOCH_TZERO is specified.</u> Select from the accepted set of values indicated in ANNEX B, Section B3. <u>This field is used by all OCM data blocks.</u>	UTC	UTC	No <u>O</u>	Yes (defaults to UTC)
EPOCH_TZERO	Default epoch to which <u>all</u> relative times are referenced in data blocks, <u>unless overridden by block specific EPOCH_TZERO values</u> (For (for format specification, see 7.5.10.). The time scale of EPOCH_TZERO is controlled via the "TIME_SYSTEM" keyword. <u>This field is used by all OCM data blocks.</u>		2001-11-06T11:17:33	Yes <u>M</u>	Yes
SCLK_EPOCH	Defines the epoch corresponding to t=0 for the spacecraft clock. This is only used if the spacecraft clock (SCLK) timescale is employed by the user.	<u>±0.0 [s]</u>	-5000.0 1980-01-06T00:00:00	No <u>O</u>	No

CCSDS PROPOSED STANDARD FOR ORBIT DATA MESSAGES

Keyword	Description	Default (if any)	Examples of Values	Mandatory/M/O/C	Any OCM sections relying upon this field?
SCLK_SEC_PER_SIEC	Defines the number of clock seconds occurring during one SI second. <u>This clock rate may vary with time and is the current approximate value.</u> This is only used if the spacecraft clock (SCLK) timescale is employed by the user.	1.0 [s]	2.5 [s]	No O	No
PREVIOUS_MESSAGE_EPOCH	Creation epoch of the previous message from this originator for this particular space object. For format specification, see 7.5.10. The time scale of this epoch is UTC. NOTE: One can may provide the previous message epoch without supplying the PREVIOUS_MESSAGE_ID, and vice versa.		2001-11-06T11:17:33	No O	No
NEXT_MESSAGE_EPOCH	Anticipated (or actual) epoch of the next message from this originator for this particular space object. For format specification, see 7.5.10. The time scale of this epoch is UTC. NOTE: One can may provide the next message epoch without supplying the NEXT_MESSAGE_ID, and vice versa.		2001-11-07T11:17:33	No O	No
START_TIME	Time of the earliest data contained in the OCM, specified as either a relative or absolute time tag.		0.0 2001-11-06T00:00:00	No O	No
ENDSTOP _TIME	Time of the latest data contained in the OCM, specified as either a relative or absolute time tag.		86400.0 2001-11-08T00:00:00	No O	No
TIME_SPAN	Span of time that the OCM covers, measured in days. TIME_SPAN is defined as (ENDSTOP _TIME - START_TIME), measured in days, irrespective of whether START_TIME or ENDSTOP _TIME are actually provided by the message creator.		20.0 [d]	No O	No
TAIMUTC_AT_TZERO	Difference (TAI – UTC) in seconds (i.e. total number of leap seconds elapsed since 1958) as modeled by the message originator at epoch “EPOCH_TZERO”.		36 [s]	No O	No
UT1MUTC_AT_TZERO	Difference (UT1 – UTC) in seconds, as modeled by the originator at epoch “EPOCH_TZERO”.		0.357 [s]	No O	No
EOP_SOURCE	Free text field specifying the source and version of the message originator’s Earth Orientation Parameters (EOP) used in the creation of this message, including leap seconds, TAI-UT1, etc.		CELESTRAK	No O	No

Keyword	Description	Default (if any)	Examples of Values	Mandatory M/O/C	Any OCM sections relying upon this field?
INTERP_METHOD_EOP	Free text field specifying the method used to select or interpolate sequential EOP data.	LINEAR	PRECEDING_VALUE NEAREST_NEIGHBOR LINEAR LAGRANGE_ORDER_5	No	No
SW_SOURCE	Free text field specifying the source and version of the message originator's space weather data used in the creation of this message.		CELESTRAK	No	No
INTERP_METHOD_SW	Free text field specifying the method used to select or interpolate sequential space weather data.	LINEAR	PRECEDING_VALUE NEAREST_NEIGHBOR LINEAR LAGRANGE_ORDER_5	No	No
CELESTIAL_SOURCE	Free text field specifying the source and version of the message originator's celestial body (e.g., Sun/Earth/Planetary) ephemeris data used in the creation of this message.		JPL_DE_FILES	No	No
TCOEFF_SOURCE	Free text field specifying the source and version of the message originator's timing coefficients data used in the creation of this message.		JPL	No	No
META_STOP	End of the metadata section.	n/a		n/a	No

6.2.4 OCM DATA: ORBIT STATE TIME HISTORY

6.2.4.1 Table 6-4 provides an overview of the OCM orbit state time history (“ephemeris”) section. Only those keywords shown in Table 6-4 shall be used in the OCM orbit state time history data specification.

6.2.4.2 Each orbit state time history data block must begin with keyword ORB_START and end with keyword ORB_STOP.

6.2.4.3 Multiple orbit state data blocks shall appear in an OCM only if they are delimited by separate ORB_START and ORB_STOP keywords

6.2.4.4 Each orbit state time history data block should ~~be unique~~ differ from all others in at least one of the following respects:

- 1) the selected element set (ORB_TYPE) ~~is unique~~
- 2) the orbit basis (~~ORB BASIS ID~~) ~~PREDICTED, — DETERMINED_OD, DETERMINED_TLM, SIMULATION, OTHER~~ ~~is unique~~
- 3) the orbit ~~state time history is based upon a unique orbit~~ determination, navigation solution, or simulation (ORB BASIS ID)
- 4) the reference frame is unique (ORB REF FRAME)
- 5) the orbit center is unique (CENTER_NAME)

6) the data interval timespan is unique (i.e., has no overlap with any other data interval(s))

6.2.4.5 ~~In the event that the only difference between~~Where multiple orbit state time history data blocks ~~is are provided for the selected element set (same ORB_TYPE), reference frame (ORB_REF_FRAME)BASIS and/or orbit center (CENTER_NAME), ORB_BASIS_ID,~~ the top-most depiction (i.e., the time history occurring first in the OCM) shall be adopted as the true or master depiction, ~~and those subsequent data blocks shall be treated as containing derivative depictions provided purely for informational purposes.~~

6.2.4.6 Each orbit state time history shall be time-ordered to be monotonically increasing.

6.2.4.7 Positionally-discontinuous orbit states (i.e., separated by a gap in the orbit state time history data across which interpolation should not be performed) shall be represented by separate orbit state time history data blocks.

6.2.4.8 Velocity-discontinuous orbit states (i.e., by introduction of an impulsive maneuver) shall be represented by separate orbit state time history data blocks.

6.2.4.9 All orbit state time history blocks must contain a sufficient number of data records to allow the recommended interpolation method to be carried out consistently throughout the time span.

6.2.4.10 If the user includes orbit states at key mission events or times, it may be useful to provide times, names, and significance for such mission events in the descriptive comment line(s) immediately following the ORB_START keyword.

6.2.4.11 Each line of orbit ephemeris data shall be provided in fixed order beginning with an absolute or relative time tag, followed by the corresponding orbit state elements (as defined by ORB_TYPE; (see SANA registry ~~[17]~~[11] and ANNEX B, Section B7).

6.2.4.12 At least one space character must be used to separate the items in each orbit ephemeris data line.

6.2.4.13 The digits of precision and time steps suitable for interpolation of an orbit ephemeris time history should be chosen according to best practice to avoid positional and interpolation loss of precision ~~[M-6]~~[ANNEX N, Reference N-6].

6.2.4.14 If an orbit state time history section is included in the message, a corresponding perturbations section should be included as well to specify the perturbations incorporated in these orbit states.

6.2.4.15 The CENTER_NAME shall be used to specify the origin of the reference frame that the orbit time history is specified in. The specified center may either be a natural, gravitationally-attracting body such as is provided in ANNEX B Section B2, or it may be a non-gravitationally-attracting origin to allow relative positional time histories. If a non-gravitationally-attracting origin is selected, however, then the specified ORB_TYPE shall be

confined to Cartesian or spherical coordinates, where the reference frame may be rotating or inertially fixed.

Table 6-4: OCM Data: Orbit State Time History

Keyword	Description	Units	Default (if any)	Examples of Values	Mandate Yes <u>M/O/C</u>
ORB_START	Start of an orbit state vector or time history section.	n/a		n/a	Yes <u>M</u>
COMMENT	Comments (a contiguous set of one or more comment lines is allowed in the Orbit State Time History section only immediately after the ORB_START key word; see 7.7 for comment formatting rules).	n/a		This is a comment	Yes <u>O</u>
ORB_ID	Optional alphanumeric free-text string containing the identification number for this orbit state time history block.	n/a		ORB_20160402_XYZ	Yes <u>O</u>
ORB_PREV_ID	Optional alphanumeric free-text string containing the identification number for the previous orbit time history block. Note: if the message is not part of a sequence of orbit time histories or if this orbit time history is the first in a sequence of orbit time histories, then ORB_PREV_ID should be excluded from this message.	n/a		ORB20160305A	Yes <u>O</u>
ORB_NEXT_ID	Optional alphanumeric free-text string containing the identification number for the next orbit time history block. Note: if the message is not part of a sequence of orbit time histories or if this orbit time history is the last in a sequence of orbit time histories, then ORB_NEXT_ID should be excluded from this message.	n/a		ORB20160305C	Yes <u>O</u>
ORB_BASIS	Basis of this Orbit State time history data, this is free text field with the following suggested values: <ol style="list-style-type: none"> 1. “PREDICTED”. 2. “DETERMINED_OD” when estimated from observation-based orbit determination reconstruction and/or calibration. 3. “DETERMINED_TLM” when read directly from telemetry. 4. “SIMULATED” for generic simulations, future mission design and optimization studies 5. “OTHER” for other bases of this data <p>2. Note: For definitive OD performed onboard whose solutions have been telemetered to the ground for inclusion in an OCM, the ORB_BASIS will be considered to be DETERMINED_OD.</p> <ol style="list-style-type: none"> 3. “DETERMINED_TLM” when read directly from telemetry, e.g., based on inertial navigation systems or GNSS data. 4. “SIMULATED” for generic simulations, future mission design studies, and optimization studies. 5. “OTHER” for other bases of this data. 	n/a	PREDICTED	PREDICTED	Yes <u>O</u>

CCSDS PROPOSED STANDARD FOR ORBIT DATA MESSAGES

Keyword	Description	Units	Default (if any)	Examples of Values	Mandate ry M/O/ C
ORB_BASIS_ID	Optional alphanumeric free-text string containing the identification number for the orbit determination, navigation solution, or simulation upon which this orbit state time history block is based. <u>Where a matching orbit determination block accompanies this orbit state time history, the ORB_BASIS_ID should match the corresponding OD_ID.</u>	n/a		OD_5910	Ne O
INTERPOLATION	This keyword may be used to specify the recommended interpolation method for ephemeris data in the immediately following set of ephemeris lines. PROPAGATE indicates that orbit propagation is the preferred method to obtain states at intermediate times, via either a midpoint-switching or endpoint switching approach.	n/a	HERMITE	HERMITE LINEAR LAGRANGE PROPAGATE	Ne O
INTERPOLATION_DEGREE	Recommended interpolation degree for ephemeris data in the immediately following set of ephemeris lines. Must be an integer value. This keyword must be used if the 'INTERPOLATION' keyword is used and set to anything other than PROPAGATE.	n/a	3	5 1	Ne O
ORB_AVERAGING	Specifies whether the provided orbit state/elements are based upon either osculating or mean elements, and if so, which mean element definition is employed. The intent of this field is to allow the user to correctly interpret how to use the provided orbit elements and know how to use them operationally. Values should be selected from the accepted set indicated in ANNEX B, Section B12. If an alternate single- or double-averaging formulation is used other than provided, the user may name as mutually agreed by message exchange participants.	n/a	OSCULATING	OSCULATING BROUWER KOZAI (other...)	Ne O
CENTER_NAME	Origin of the orbit reference frame, which may be a natural solar system body (planets, asteroids, comets, and natural satellites), including any planet barycenter or the solar system barycenter, or another reference frame center (such as a spacecraft, ground station , formation flying reference "chief" spacecraft, etc.). Natural bodies shall be selected from the accepted set of values indicated in ANNEX B, Section B2. For spacecraft, it is recommended to use either the Object name or international designator of the participant as catalogued in the UN Office of Outer Space Affairs designator index (reference {2} -3). Alternately, the OBJECT_DESIGNATOR may be used. For other reference frame origins, this field is a free text descriptor which can may draw upon ground station name, etc. <u>other naming conventions and sources.</u>	n/a	EARTH	EARTH MOON SOLAR SYSTEM BARYCENTER SUN ISS EROS EARTH_SUN _L2 ISS EGLIN	Ne O

CCSDS PROPOSED STANDARD FOR ORBIT DATA MESSAGES

Keyword	Description	Units	Default (if any)	Examples of Values	Mandatory M/O/C
ORB_REF_FRAME	Reference frame of the orbit state time history. Select from the accepted set of values indicated in ANNEX B, Section B4.	n/a	If not intrinsic to selected orbit set, default is ITRF2000ICRF3	J2000	NoO
ORB_FRAME_EPOCH	Epoch of the orbit data reference frame, if not intrinsic to the definition of the reference frame. See 7.5.10 for formatting rules.	n/a	EPOCH_TZER 0	2001-11-06T11:17:33 2002-204T15:56:23Z	NoO
<u>USEABLE_START_TIME</u> <u>USEABLE_STOP_TIME</u>	<u>Optional start and end of USEABLE time span covered by ephemeris data immediately following this metadata block. For format specification, see 7.5.10.</u> <u>These optional keywords allow the message creator to introduce fictitious (but numerically smooth) data nodes outside of the actual data time history to support interpolation methods requiring more than two nodes (e.g., pure higher-order Lagrange interpolation methods). The use of these keywords and introduction of fictitious node points are optional and may not be necessary.</u> <u>The USEABLE_START_TIME time tag at a new block of ephemeris data must be greater than or equal to the USEABLE_STOP_TIME time tag of the previous block.</u>		(defaults to all data being valid)	1996-12-18T14:28:15.11721996-277T07:22:54	O
ORB_TYPE	Specifies the orbit element set type; selected per ANNEX B, section B7.	n/a	CARTPV	n/a	NoO
<u>ORB_UNITS</u>	<u>A comma-delimited set of SI unit designations for each element of the orbit state time history after the orbit state time tag shall be provided in aggregate as an alphanumeric free-text string enclosed in square brackets. All orbit state elements shall have a corresponding units entry; non-dimensional values (such as orbit eccentricity) shall be labelled as "nd". Suggested units are recommended for each ORB_TYPE, per ANNEX B, Section B7.</u>			[km,km,km,km/s,km/s,km/s]	M
<u>... < Insert orbit lines state time history here ></u>	Orbit time history line(s) shall be formatted as described above . Units are as specified in specified in 6.2.4.11, containing time and orbit elements as selected by ORB_TYPE in the SANA Orbital Elements registry (ANNEX B, Section B7). Units are as specified in this registry).				YesM
ORB_STOP	End of an orbit state vector or time history section.	n/a		n/a	YesM

6.2.5 OCM DATA: SPACE OBJECT PHYSICAL CHARACTERISTICS

6.2.5.1 Table 6-5 gives an overview of the OCM space object physical characteristics section. Only those keywords shown in table 6-5 shall be used in OCM space object physical characteristics data.

6.2.5.2 At most, only one space object physical characteristics section shall appear in an OCM.

6.2.5.3 The space object physical characteristics data section in the OCM shall be indicated by two keywords: PHYS_START and PHYS_STOP.

6.2.5.4 The Space Object Optimally-Encompassing Box (OEB) parameters are defined in further detail in ANNEX C.

Table 6-5: OCM Data: Space Object Physical Characteristics

Keyword	Description	Units	Default (if any)	Examples of Values	Mandatory M/O/C
PHYS_START	Start of a Space Object Physical Characteristics specification	n/a			YesM
COMMENT	Comments (a contiguous set of one or more comment lines is allowed in the OCM Space Object Physical Characteristics only immediately after the PHYS_START key word; see 7.7 for comment formatting rules).	n/a		This is a comment	NoQ
MANUFACTURER	Free text field containing the satellite manufacturer name.			BOEING	NoQ
BUS_MODEL	Free text field containing the satellite manufacturer's spacecraft bus model name.			702	NoQ
DOCKED_WITH	Free text field containing a comma-separated list of other space objects that this object is docked to.			ISS	NoQ
DRAG_ADDL_AREA	Drag Additional drag Area (A_D) facing the relative wind vector, not already incorporated into the attitude-dependent "AREA_ALONG_OEB" parameters.	m**2		2.5	NoQ
DRAG_COEFF_NOM	Drag Nominal drag Coefficient (C_D)- $C_{D,Nom}$. If the atmospheric drag coefficient, C_D , is set to zero, no atmospheric drag shall be considered.	n/a		2.2	NoQ
DRAG_SCALEUNCERTAINTY	Drag scale factor (1.0 represents no scaling)-Drag coefficient one sigma (1 σ) percent uncertainty, where the actual range of drag coefficients to within 1 σ shall be obtained from $\left[1.0 \pm \frac{DRAGUNCERTAINTY}{100.0}\right] (C_{D,Nom})$. This factor is intended to allow operators to supply the nominal ballistic coefficient components while accommodating ballistic coefficient uncertainties (i.e. 1.06 represents a +6 percent error).	n/a%	1 0.0	1 0.0	NoQ

CCSDS PROPOSED STANDARD FOR ORBIT DATA MESSAGES

	Keyword	Description	Units	Default (if any)	Examples of Values	Mandatory M/O/C
	INITIAL_MASS	Space object total mass at beginning of life.	kg		500	NeO
	MASS	Space object total mass (i.e., "wet mass") at the current reference epoch "EPOCH_TZERO".	kg		472.3	NeO
	DRY_MASS	Space object dry mass (without propellant).	kg		300	NeO
	OEB_PARENT_FRAME	ReferenceParent reference frame which maps to the Optimally Enclosing Box (OEB) frame via the Euler sequence OEB_ROLL and OEB_YAW, quaternion-based transformation defined in ANNEX C, Section C1. Select from the accepted set of values indicated in ANNEX B, Sections B4 and B5.	n/a	RIC	ITRF1997	NeO
	OEB_PARENT_FRAME_EPOCH	Epoch of the OEB referenceparent frame, if not intrinsic to the definition of the reference frame. (See 7.5.10 for formatting rules).	n/a	EPOCH_TZERO	2001-11-06T11:17:33 2002-204T15:56:23Z	NeO
	OEB_Q1	$q_1 = e_1 * \sin(\theta\phi/2)$, where per ANNEX N, Reference [N-1], $\theta\phi$ = Euler rotation angle and e_1 = 1st component of Euler rotation axis for the rotation that maps from the OEB_PARENT_FRAME (defined above) to the frame aligned with the Optimally-Encompassing Box (OEB) (defined in ANNEX C, Section C1). A value of "-999" denotes a tumbling space object.	n/a		-0.575131822	NeO
	OEB_Q2	$q_2 = e_2 * \sin(\theta\phi/2)$, where per ANNEX N, Reference [N-1], $\theta\phi$ = Euler rotation angle and e_2 = 2nd component of Euler rotation axis for the rotation that maps from the OEB_PARENT_FRAME (defined above) to the frame aligned with the Optimally-Encompassing Box (defined in ANNEX C, Section C1). A value of "-999" denotes a tumbling space object.	n/a		-0.280510532	NeO
	OEB_Q3	$q_3 = e_3 * \sin(\theta\phi/2)$, where per ANNEX N, Reference [N-1], $\theta\phi$ = Euler rotation angle and e_3 = 3rd component of Euler rotation axis for the rotation that maps from the OEB_PARENT_FRAME (defined above) to the frame aligned with the Optimally-Encompassing Box (defined in ANNEX C, Section C1). A value of "-999" denotes a tumbling space object.	n/a		-0.195634856	NeO
	OEB_QC	$q_c = \cos(\theta/2)$, where $\theta q_c = \cos(\phi/2)$, where per ANNEX N, Reference [N-1], ϕ = Euler axis/angle rotation angle for the rotation that maps from the OEB_PARENT_FRAME (defined above) to the frame aligned with the Optimally-Encompassing Box (ANNEX C, Section C1). q_c shall be made non-negative by convention. A value of "-999" denotes a tumbling space object.	n/a		0.743144825	NeO
	OEB_MAX	Maximum physical dimension (along \hat{X}_{OEB}) of the Optimally-Encompassing Box (OEB) in meters,	m		1	NeO
	OEB_MEDINT	MediumIntermediate physical dimension (along \hat{Y}_{OEB}) of Optimally-Encompassing Box (OEB) normal to OEB_MAX direction.	m		0.5	NeO
	OEB_MIN	Minimum physical dimension (along \hat{Z}_{OEB}) of Optimally-Encompassing Box (OEB) in direction normal to both OEB_MAX and OEB_MEDINT directions.	m		0.3	NeO
	AREA_ALONG_OEB_MAX	Cross-sectional area of space object when viewed along max OEB (\hat{X}_{OEB}) direction as defined in ANNEX C.	m**2		0.15	NeO

CCSDS PROPOSED STANDARD FOR ORBIT DATA MESSAGES

Keyword	Description	Units	Default (if any)	Examples of Values	Mandatory M/O/C
AREA_ALONG_OEB_MEDIINT	Cross-sectional area of space object when viewed along medium <u>intermediate</u> OEB (\hat{y}_{OEB}) direction as defined in ANNEX C.	m**2		0.3	NeO
AREA_ALONG_OEB_MIN	Cross-sectional area of space object when viewed along minimum OEB (\hat{z}_{OEB}) direction as defined in ANNEX C.	m**2		0.5	NeO
AREA_MIN_FOR_PC	Minimum cross-sectional area for collision probability estimation purposes.	m**2		1.0	NeO
AREA_MAX_FOR_PC	Maximum cross-sectional area for collision probability estimation purposes.	m**2		1.0	NeO
AREA_AVGTYP_FOR_PC	Typical (50 th percentile) cross-sectional area sampled over all space object orientations for collision probability estimation purposes.	m**2		1.0	NeO
RCS	Typical (50 th percentile) effective Radar Cross Section of the space object sampled over all possible viewing angles.	m**2		1.25	NeO
RCS_MIN	Minimum Radar Cross Section observed for this object.	n/a		1.1	NeO
RCS_MAX	Maximum Radar Cross Section observed for this object.	n/a		2.5	NeO
SOLAR_RADSRP_ADDL_AREA	Solar Radiation Pressure Area (A_R) facing the Sun, not already incorporated into the attitude-dependent "AREA_ALONG_OEB" parameters (computed from $\{ \text{AREA_ALONG_OEB_MAX} \cos(\theta_1) + \text{AREA_ALONG_OEB_MEDIINT} \cos(\theta_2) + \text{AREA_ALONG_OEB_MIN} \cos(\theta_3) \}$ Where θ_i represents the angle between the normal to each MAX/MED/MIN face and the direction to the Sun.	m**2		1.0	NeO
SOLAR_RAD_COEFF_NOM	<u>Nominal</u> Solar Radiation Pressure Coefficient (C_R C_{RNom}). Note that if the solar radiation coefficient, C_R , is set to zero, no solar radiation pressure shall be considered.	n/a		1.7	NeO
SOLAR_RAD_SCALEUNCERTAINTY	Solar Radiation Pressure scale factor (1.0 represents no scaling). <u>Solar Radiation Pressure one sigma (1σ) percent uncertainty, where the actual range of SRP coefficients to within 1σ shall be obtained from</u> $\left[1.0 \pm \frac{SRP_{UNCERTAINTY}}{100.0} \right] (C_{RNom})$. This factor is intended to allow operators to supply the nominal ballistic coefficient components while accommodating ballistic coefficient uncertainties (i.e. 1.06 represents a +6 percent error).	n/a		1.0	NeO
VM_ABSOLUTE	Typical (50 th percentile) absolute Visual Magnitude of the space object sampled over all possible viewing angles and "normalized" as discussed in Annex C, Section C-2 to a 1 AU Sun-to-target distance, a phase angle of 0° and a 40,000 km target-to-sensor distance (equivalent of GEO satellite tracked at 15.6° above local horizon).	n/a		15.0	NeO
VM_APPARENT_MIN	Minimum apparent Visual Magnitude observed for this space object.	n/a		19.0	NeO
VM_APPARENT	Typical (50 th percentile) apparent Visual Magnitude observed for this space object.	n/a		15.0	NeO

CCSDS PROPOSED STANDARD FOR ORBIT DATA MESSAGES

	Keyword	Description	Units	Default (if any)	Examples of Values	Mandatory M/O/C
	VM_APPARENT_MAX	Maximum apparent Visual Magnitude observed for this space object (NOTE: The "MAX" value represents the brightest observation, which associates with a lower Vmag).	n/a		16.0	NeO
	REFLECTIVITY	Typical (50 th percentile) coefficient of reflectivity of the space object over all possible viewing angles, ranging from -1.0 to +1.0.	n/a		0.7	NeO
	ATT_CONTROL_MODE	Free-text specification of primary mode of attitude control for the space object. Suggested examples include: <ul style="list-style-type: none"> - THREE_AXIS - SPIN - DUAL_SPIN - TUMBLING - GRAVITY_GRADIENT 	n/a		CMGS	NeO
	ATT_ACTUATOR_TYPE	Free-text specification of type of actuator for attitude control. Suggested examples include: <ul style="list-style-type: none"> - ATT_THRUSTERS - ACTIVE_MAG_TORQUE - PASSIVE_MAG_TORQUE - CMGS - NONE - OTHER 	deg		0.3	NeO
	ATT_KNOWLEDGE	Accuracy of attitude knowledge.	deg		0.3	NeO
	ATT_CONTROL	Ability to control attitude Accuracy of attitude control system (ACS) to maintain attitude, assuming attitude knowledge was perfect (i.e., deadbands).	deg		2.0	NeO
	ATT_POINTING	Combined ability Overall accuracy of spacecraft to both maintain attitude, including attitude knowledge errors and control attitude ACS operation.	deg		2.3	NeO
	AVG_MANEUVER_FREQ	Average maneuver frequency, measured in the number of orbit- or attitude-adjust maneuvers per year.	per yr		20.0	NeO
	MAX_THRUST	Maximum composite thrust the spacecraft can accomplish in any single body-fixed direction.	N		1.0	NeO
	DV_BOL	Total ΔV capability of the spacecraft at beginning of life.	km/s		14000 1.0	NeO
	DV_REMAINING	Total ΔV remaining for the spacecraft.	km/s		5000 0.2	NeO
	IXX	Moment of Inertia about the X-axis of the space object's primary body frame (e.g. SC_Body_1) – see ANNEX N, Reference [N-1].	kg*m **2		1000.0	NeO
	IYY	Moment of Inertia about the Y-axis.	kg*m **2		800.0	NeO
	IZZ	Moment of Inertia about the Z-axis.	kg*m **2		400.0	NeO
	IXY	Inertia Cross Product of the X & Y axes.	kg*m **2		20.0	NeO
	IXZ	Inertia Cross Product of the X & Z axes.	kg*m **2		40.0	NeO
	IYZ	Inertia Cross Product of the Y & Z axes.	kg*m **2		60.0	NeO
	PHYS_STOP	End of the Space Object Physical Characteristics specification.	n/a			YesM

6.2.6 OCM DATA: ~~ORBIT STATE~~ COVARIANCE TIME HISTORY

6.2.6.1 Table 6-6 provides an overview of the OCM ~~orbit state~~ covariance time history section. Only those keywords shown in Table 6-6 shall be used in the OCM ~~orbit state~~ covariance time history data specification.

6.2.6.2 Each ~~orbit state~~ covariance time history data block must begin with keyword COV_START and end with keyword COV_STOP.

6.2.6.3 Multiple orbit state covariance data blocks shall appear in an OCM only if they are delimited by separate COV_START and COV_STOP keywords

6.2.6.4 Each ~~orbit state~~ covariance time history data block should **be-unique/differ** from all others in at least one of the following respects:

- 1) ~~7) _____ the selected covariance element set (COV_TYPE) is unique~~
- 2) ~~the covariance time history basis (PREDICTED, DETERMINED_OD, EMPIRICAL, SIMULATION, OTHER)~~
- 8) ~~the covariance time history is based upon a unique~~ the orbit basis (COV BASIS)
- 3) ~~9) _____ the orbit determination, navigation solution, or simulation (COV BASIS ID)~~
- 4) ~~10) _____ the reference frame is unique (COV REF FRAME)~~
- 5) ~~the orbit center is unique~~
- 6) ~~11) _____ the data interval timespan is unique (i.e., has no overlap with any other data interval(s))~~

6.2.6.5 ~~In the event that the only difference between~~ Where multiple covariance time history data blocks is are provided for the selected element set (same COV_TYPE) BASIS and/or reference frame (COV_REF_FRAME), BASIS ID, the top-most depiction ~~(i.e., the time history occurring first in the OCM)~~ shall be adopted as the true or master depiction, ~~and those subsequent data blocks shall be treated as containing derivative depictions provided purely for informational purposes.~~

6.2.6.6 Each ~~orbit state~~ covariance time history shall be time-ordered to be monotonically increasing.

6.2.6.7 Discontinuous covariance time segments shall be represented by separate ~~orbit state~~ covariance time history data blocks.

6.2.6.8 If the user includes orbit state covariances at key mission events or times, it may be useful to provide times, names, and significance for such mission events in descriptive comment line(s) immediately following the COV_START keyword.

6.2.6.9 Values in the orbit state covariance matrix shall be expressed in the applicable reference frame specified via the 'COV_REF_FRAME' keyword.

6.2.6.10 If ~~an orbit state~~a covariance time history section is included in the message, a corresponding perturbations section should be included as well to specify the perturbations incorporated in these ~~orbit state~~covariances.

~~6.2.6.10~~**6.2.6.10.1** Each covariance time history line shall begin with either a relative or absolute time tag corresponding to the specified covariance matrix.

6.2.6.11 For COV_TYPE = TEIGVAL3EIGVEC3, the covariance time tag and eigenvalues and eigenvectors shall all be presented on a single line, comprised of the time tag, followed by the major, ~~medium~~intermediate, and minor eigenvalues and then followed by the major, ~~medium~~intermediate, and minor eigenvectors, respectively.

~~6.2.6.12~~ For all other COV_TYPE values:

~~6.2.6.12~~ The order in which data items are given shall be fixed, with, the covariance time tag and covariance matrix elements in each row shall be presented on a single line.

~~6.2.6.12.1~~ The composition of covariates and the number “N” of elements both being covariance matrix shall be commensurate with the specified COV_TYPE value.

~~6.2.6.12.2~~ Each covariance shall be preceded by a single line containing the relative or absolute time tag of the covariance matrix.

~~6.2.6.12.2~~ Directly following the time tag specification line, each on the same line as the time tag, all elements of the “N” rows of the “NxN” lower triangular covariance matrix shall be presented containing from one in rowwise fashion, beginning with element [1,1] to “N” numerical], followed by [2,1], [2,2], [3,1], [3,2] and so on, until all LTM entries depending on what row of the matrix is being represented (first row has one element, second row has two, continuing (there are $\sum_{i=1}^N i$ entries in total) as shown and ordered in this fashion until the “Nth” row has “N” elements). Units are as specified in the Figure 6-1.

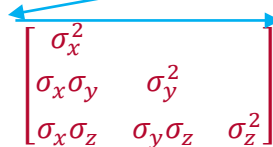

~~6.2.6.12.3~~ **Figure 6-1: Covariance portion of the SANA registry [18]. LTM ordering following time tag.**

~~6.2.6.12.4~~**6.2.6.12.3** At least one space character must be used to separate the items in each covariance matrix data line.

6.2.6.13 Variance and covariance values shall be expressed in floating point or scientific notation as related in 7.5. The digits of precision and time steps suitable for interpolation of a covariance time history should be chosen according to best practice to avoid covariance ~~and~~ interpolation loss of precision ~~[M-6].~~[ANNEX N, Reference N-6].

NOTE: ~~Interpolation of~~ It is strongly recommended that covariance ~~matrices at neighboring~~ relative ~~matrix~~ time ~~points shall~~ history interpolation be done by (1) eigenvalue/vector decomposition; (2) linear (or higher-order) interpolation of neighboring eigenvalues; (3) Euler axis/angle rotation of eigenvectors at intermediate time(s) of interest; and (4) Re-composition of attained eigenvalues and eigenvectors into covariances at time(s) of interest ~~[M-9].~~ (see ANNEX C, Section C5 and ANNEX N, References [N-9, N-10, and N-11]). Direct interpolation of covariance matrix components or failure to incorporate sufficient digits of precision on the interpolated covariance elements can produce invalid (non-positive-semidefinite) covariances.

Table 6-6: OCM Data: Covariance Time History

CCSDS PROPOSED STANDARD FOR ORBIT DATA MESSAGES

	Keyword	Description	Units	Default (if any)	Examples of Values	Mandatory M/O/C
	COV_START	Start of a covariance time history section.	n/a		n/a	YesM
	COMMENT	Comments (a contiguous set of one or more comment lines is allowed in the OCM Covariance Time History section only immediately after the COV_START key word; see 7.7 for comment formatting rules).	n/a		This is a comment	NoO
	COV_ID	Optional alphanumeric free-text string containing the identification number for this covariance time history block.	n/a		COV_20160402_XYZ	NoO
	COV_PREV_ID	Optional alphanumeric free-text string containing the identification number for the previous covariance time history. Note: if the message is not part of a sequence of covariance time histories or if this covariance time history is the first in a sequence of covariance time histories, then COV_PREV_ID should be excluded from this message.	n/a		COV_20160305A	NoO
	COV_NEXT_ID	Optional alphanumeric free-text string containing the identification number for the next covariance time history. Note: if the message is not part of a sequence of covariance time histories or if this covariance time history is the last in a sequence of covariance time histories, then COV_NEXT_ID should be excluded from this message.	n/a		COV_20160305C	NoO
	COV_BASIS	<p>Basis of this covariance time history data. This is free text field with the following suggested values:</p> <ol style="list-style-type: none"> 1. "PREDICTED" 2. "DETERMINED_OD" when estimated from observation-based orbit determination reconstruction and/or calibration. <u>Note: For definitive OD performed onboard whose solutions have been telemetered to the ground for inclusion in an OCM, the COV_BASIS shall be considered to be DETERMINED_OD.</u> 3. EMPIRICAL (for empirically-determined such as overlap analyses) 4. SIMULATION for simulation-based (including Monte Carlo) estimations, future mission design <u>studies</u>, and optimization studies. 5. "OTHER" for other bases of this data <p>5. <u>Note: For definitive OD performed onboard whose solutions have been telemetered to the ground for inclusion in an OCM, the COV_BASIS shall be considered to be DETERMINED_OD.</u></p>	n/a	PREDICTED	PREDICTED EMPIRICAL DETERMINED_OD SIMULATION OTHER	NoO
	COV_BASIS_ID	Optional alphanumeric free-text string containing the identification number for the orbit determination, navigation solution, or simulation upon which this orbit <u>state covariance</u> time history block is based. <u>Where a matching orbit determination block accompanies this covariance time history, the COV_BASIS_ID should match the corresponding OD ID.</u>	n/a		OD_5910	NoO
	COV_REF_FRAME	Reference frame of the covariance time history. Select from the accepted set of values indicated in ANNEX B, Section B4 and B5.	n/a	TNW <u>INERTIAL</u>	J2000	NoO

CCSDS PROPOSED STANDARD FOR ORBIT DATA MESSAGES

	Keyword	Description	Units	Default (if any)	Examples of Values	Mandatory M/O/C
COV_	FRAME_EPOCH	Epoch of the covariance data reference frame, if not intrinsic to the definition of the reference frame. See 7.5.10 for formatting rules.	n/a	EPOCH_TZERO	2001-11-06T11:17:33 2002-204T15:56:23Z	No <u>O</u>
COV_	TYPE	Indicates covariance composition. Select from ANNEX B, Sections B7 and B8.	n/a	CARTPV	n/a	Yes
COV_	SCALE_MIN	Minimum scale factor to apply to this covariance data to achieve realism.	n/a	1	0.5	No <u>O</u>
COV_	SCALE_MAX	Maximum scale factor to apply to this covariance data to achieve realism.	n/a	1	5.0	No <u>O</u>
COV_	CONFIDENCE	A measure of the confidence in the covariance errors matching reality, as characterized via a Wald test, a Chi-squared test, the log of likelihood, or a numerical representation per mutual agreement. This is a free text field.	n/a %		<u>50%</u>	No <u>O</u>
COV_	TYPE	<u>Indicates covariance composition. Select from ANNEX B, Sections B7 and B8.</u>		<u>CARTPV</u>	<u>n/a</u>	<u>O</u>
COV_	UNITS	<u>A comma-delimited set of SI unit designations for each element of the covariance time history after the covariance time tag shall be provided in aggregate as an alphanumeric free-text string enclosed in square brackets. Specifically, these units designations shall correspond to the standard deviations (or square roots) of each of the covariance matrix diagonal elements (or variances), respectively. All diagonal elements shall have a corresponding units entry; non-dimensional values (such as dispersion in orbit eccentricity) shall be labelled as "nd". Suggested units are recommended for each COV TYPE, per ANNEX B, Sections B7 and B8).</u>			<u>[km,km,km,km/s,km/s,km/s]</u>	<u>M</u>
...	< Insert covariance data here >	Covariance data shall be provided as specified above. Units are as specified in the SANA Covariance Matrices registry. Covariance time history line(s) shall be formatted as specified in 6.2.6.10.1 through 6.2.6.13 containing time and covariance elements as selected by COV TYPE in the SANA Orbital Elements or the Additional Covariance Representations registry (ANNEX B, Section B7 and B8). Units are as specified in these registries).				Yes <u>M</u>
COV_	STOP	End of a covariance time history section.	n/a		n/a	Yes <u>M</u>

~~6.2.7—OCM DATA: STATE TRANSITION MATRIX TIME HISTORY~~

~~6.2.7.1—Table 6-7 provides an overview of the OCM state transition matrix time history section. Only those keywords shown in Table 6-7 shall be used in OCM state transition matrix time history data specification.~~

~~6.2.7.2—Each state transition matrix time history data block must begin with keyword STM_START and end with keyword STM_STOP.~~

~~6.2.7.3—Multiple state transition matrix data blocks shall appear in an OCM only if they are delimited by separate STM_START and STM_STOP keywords~~

~~6.2.7.4—Each STM data block should be be unique from all others in at least one of the following respects:~~

- ~~1) the selected orbit state element set (STM_TYPE) is unique;~~
- ~~2) the state transition matrix time history is based upon a unique orbit determination, navigation solution, or simulation;~~
- ~~3) the reference frame is unique;~~
- ~~4) the orbit center is unique;~~
- ~~5) the state transition matrix timespan is unique.~~

~~6.2.7.5—In the event that the only difference between multiple state transition matrix time history data blocks is the selected element set (STM_TYPE), reference frame (STM_REF_FRAME), orbit center (STM_CENTER_NAME) and/or STM mapping mode (STM_MAP_MODE), the top most depiction (i.e., the time history occurring first in the OCM) shall be adopted as the true or master depiction, and those subsequent data blocks shall be treated as containing derivative depictions provided purely for informational purposes.~~

~~6.2.7.6—The STM_TYPE keyword value shall be selected from ANNEX B, Section B7 and B8, or alternately, “ICD” denotes state transition matrix composition definition via ICD.~~

~~6.2.7.7—Each state transition matrix time history shall be time ordered to be monotonically increasing.~~

~~6.2.7.8—Discontinuous segments of state transition matrix time histories (such as occurs when the STM basis state and accompanying STM_ORB_TIME is changed) shall be represented by separate STM data blocks.~~

~~6.2.7.9—No interpolation of the state transition matrix time history shall be undertaken, since the state transition matrix pre and post multiplies the state (or covariance) in the mapping process to yield states and covariances that may then be properly interpolated.~~

~~6.2.7.10—If the user includes state transition matrices at key mission events or times, it may be useful to provide times, names and, significance for such mission events in the descriptive comment line(s) immediately following the STM_START keyword.~~

~~6.2.7.11 The reference frame of the state transition matrices must be provided via the ‘STM_REF_FRAME’ keyword.~~

~~6.2.7.12 Values in each state transition matrix shall be expressed in the applicable reference frame and shall be presented sequentially from upper to lower and row by row from left to right. State transition matrix values shall be expressed in standard double precision as discussed in 7.5.~~

~~6.2.7.13 Each row of each state transition matrix must be provided on a single line. The order in which data items are given shall be fixed. The elements in each row shall be defined commensurate with the STM_TYPE keyword specification. The “N” rows of the state transition matrix shall each contain “N” numbers.~~

~~6.2.7.14 At least one space character must be used to separate the items in each state transition matrix data line.~~

~~6.2.7.15 The digits of precision and time steps suitable for state transition matrix time history should be chosen to avoid STM propagation loss of precision.~~

~~6.2.7.16 If an STM time history section is included in the message, a corresponding perturbations section should be included as well to specify the perturbations incorporated in the STM data.~~

NOTE: State Transition Matrices (STMs) can be very useful in mapping both an initial state, and (separately) differences about that state, to other time(s) of interest. Following the terminology and definitions of reference [M-7], pp. 82, 778-780 and 809 allows the analyst to map states, or alternatively state differences, at time t_0 to another time t_i . As noted in reference [M-7], these are distinctly different in definition and content from each other. Both types of State Transition Matrices are supported, as specified by the STM_MAP_MODE keyword.

~~Table 6-7: OCM Data: State Transition Matrix Time History~~

Keyword	Description	Units	Default (if any)	Examples of Values	Mandatory
STM_START	Start of a state transition matrix time history	n/a		n/a	Yes
COMMENT	Comments (a contiguous set of one or more comment lines is allowed in the OCM State Transition Matrix Time History section only immediately after the STM_START key word; see 7.7 for comment formatting rules).	n/a		This is a comment	No
STM_ID	Optional alphanumeric free text string containing the identification number for this state transition matrix time history block.	n/a		STM_20160402_XYZ	No

CCSDS PROPOSED STANDARD FOR ORBIT DATA MESSAGES

Keyword	Description	Units	Default (if any)	Examples of Values	Mandatory
STM_PREV_ID	Optional alphanumeric free-text string containing the identification number for the previous state transition matrix time history block. Note: if the message is not part of a sequence of state transition matrix time history blocks or if this state transition matrix time history block is the first in a sequence of state transition matrix time history blocks, then STM_PREV_ID should be excluded from this message.	n/a		STM_20160305A	No
STM_NEXT_ID	Optional alphanumeric free-text string containing the identification number for the next state transition matrix time history block. Note: if the message is not part of a sequence of state transition matrix time history blocks or if this state transition matrix time history block is the last in a sequence of state transition matrix time history blocks, then STM_NEXT_ID should be excluded from this message.	n/a		STM_20160305C	No
STM_MAP_MODE	Indicates whether state transition matrix maps: <ul style="list-style-type: none"> — An initial state to later states (STATE) or — Initial state differences (or uncertainties) to later differences (DIFFERENCES) 	n/a	DIFFERENCES	STATE DIFFERENCES	Yes
STM_ORB_ID	ID of the orbit state at STM_ORB_STATE_TIME upon which the state transition mapping is derived and referenced			ORB_ID_001	No
STM_BASIS	Basis of this covariance time history data. This is free text field with the following suggested values: <ol style="list-style-type: none"> 1. "PREDICTED" 2. "DETERMINED_OD" when estimated from observation-based orbit determination reconstruction and/or calibration. 3. EMPIRICAL (for empirically determined such as overlap analyses) 4. SIMULATION for simulation-based (including Monte-Carlo) estimations, future mission design and optimization studies. 5. "OTHER" for other bases of this data <p>Note: For definitive OD performed onboard whose solutions have been telemetered to the ground for inclusion in an OCM, the STM_BASIS shall be considered to be DETERMINED_OD.</p>	n/a	PREDICTED	PREDICTED DETERMINED_OD EMPIRICAL SIMULATION OTHER	No
STM_BASIS_ID	Optional alphanumeric free-text string containing the identification number for the orbit determination, navigation solution, or simulation upon which this STM time history block is based	n/a		OD_5910	No

CCSDS PROPOSED STANDARD FOR ORBIT DATA MESSAGES

Keyword	Description	Units	Default (if any)	Examples of Values	Mandatory
STM_CENTER_NAME	<p>Origin of the STM reference frame, which may be a natural solar system body (planets, asteroids, comets, and natural satellites), including any planet barycenter or the solar system barycenter, or another reference frame center (such as a spacecraft, ground station, formation flying reference “chief” spacecraft, etc.).</p> <p>Natural bodies shall be selected from the accepted set of values indicated in ANNEX B, Section B2.</p> <p>For spacecraft, it is recommended to use either the Object name or international designator of the participant as catalogued in the UN Office of Outer Space Affairs designator index (reference [2]). Alternately, the OBJECT_DESIGNATOR may be used.</p> <p>For other reference frame origins, this field is a free text descriptor which can draw upon ground station name, etc.</p>	n/a	EARTH	<p>EARTH</p> <p>MOON</p> <p>SOLAR-SYSTEM</p> <p>BARYCENTER</p> <p>SUN</p> <p>ISS</p> <p>EROS</p> <p>EARTH_SUN_L2</p>	No
STM_ORB_STATE	Initial orbit state at STM_ORB_TIME from which the state transition mapping is derived and referenced. Units are as specified in Reference [B-7].			<p>2789600.0 280000.0</p> <p>1746800.0 4730.0</p> <p>2500.0 1040.0</p>	No
STM_ORB_TIME	The epoch (relative to EPOCH_TZERO or absolute) to which the STM_ORB_STATE and any state transition matrix relative times are referenced in the STM block, and at which time the STM = the identity matrix.	n/a	EPOCH_TZ ERO	<p>2001-11-</p> <p>06T11:17:33</p>	Yes
STM_REF_FRAME	Reference frame to which the state transition matrix is referenced, if not intrinsic to the definition of the STM data. Select from the accepted set of values indicated in ANNEX B, Section B4 and B5.	n/a	ICRF3	J2000	No
STM_FRAME_EPOCH	Epoch of the state transition matrix data reference frame, if not intrinsic to the definition of the reference frame (See 7.5.10 for formatting rules)	n/a	EPOCH_TZ ERO	<p>2001-11-</p> <p>06T11:17:33</p> <p>2002-</p> <p>204T15:56:23Z</p>	No
STM_TYPE	Indicates state transition matrix composition; selected from ANNEX B, Section B7 and B8, or alternately, “ICD” denotes state transition matrix composition definition via ICD	n/a	CARTPV	CARTPV	Yes
...< Insert STM data here>	State transition matrices shall be provided as specified above. Units shall be consistent with ANNEX B, Section B7 and B8, or alternately per ICD.				Yes
STM_STOP	End of a state transition matrix time history section	n/a		n/a	Yes

6.2.8.6.2.7 OCM DATA: MANEUVER SPECIFICATION

~~6.2.8.16.2.7.1~~ ~~Table 6-10~~ Table 6-7 provides an overview of the OCM maneuver specification section. Only those keywords shown in ~~Table 6-10~~ Table 6-7 shall be used ~~as Key-Value Notation keywords~~ in the OCM maneuver time history data specification.

~~6.2.8.26.2.7.2~~ The order of occurrence of these OCM Maneuver Specification keywords shall be fixed as shown in ~~Table 6-10~~ Table 6-7.

~~6.2.8.36.2.7.3~~ Maneuver data in the OCM shall be indicated by two keywords: MAN_START and MAN_STOP.

~~6.2.8.46.2.7.4~~ Multiple maneuver data blocks shall appear in an OCM only when delimited by separate MAN_START and MAN_STOP keywords.

~~6.2.8.56.2.7.5~~ The time intervals of multiple maneuver data blocks may be separated in time, abut, or overlap.

NOTE: This is done to accommodate multiple maneuver reference frames, multiple thrusters in simultaneous operation, deployments during thrusting phases, multiple basis definitions (MAN_BASIS), etc.

~~6.2.8.66.2.7.6~~ Each maneuver data block shall be assigned a maneuver device ID (MAN_DEVICE_ID) value, which specifies the unique thruster (or other propulsive device) ~~identifier corresponding to used in~~ this maneuver sequence time history data block.

- Except for the special values “ALL” and “DEPLOY”, MAN_DEVICE_ID is a free text field which allows the user to identify which specific thruster or other propulsive device performed this maneuver time history.
- A MAN_DEVICE_ID value of “ALL” shall be used to indicate that this maneuver sequence represents an aggregation of thrust, acceleration, and/or velocity increments imparted by any/all thrusters ~~and/or other perturbative forces~~ utilized in the maneuver which are not attributed to a single specific propulsive device.
- A MAN_DEVICE_ID value of “DEPLOY” shall be used to indicate that this maneuver data block represents ONLY maneuvers caused by a series of one or more deployments from this host vehicle.

~~6.2.8.7~~ ~~Each maneuver data block shall only specify a single maneuver device ID (MAN_DEVICE_ID) value.~~

~~6.2.8.86.2.7.7~~ Multiple maneuver data blocks may ~~specify~~ invoke the same maneuver device ID (MAN_DEVICE_ID) value.

~~6.2.8.9~~ ~~The basis of each~~ All specified maneuver data block is set via constituents having a common MAN_ID, MAN_BASIS. ~~Per Table 6-10, MAN_BASIS shall be one~~

of the following values:

- ~~CANDIDATE~~
- ~~PLANNED~~
- ~~ANTICIPATED~~
- ~~DETERMINED_TLM~~
- ~~DETERMINED_OD~~

~~6.2.8.10~~ Maneuver descriptions shall be designated as either MAN_IS_ADDITIVE = “YES” or “NO”.

~~6.2.7.8~~ “YES” designates that this described maneuver “constituent” and MAN_REF_FRAME shall be added together to any/all other additive designated maneuver descriptions within the same MAN_BASIS, MAN_REF_FRAME and MAN_CENTER_NAME categories to arrive at obtain the total composite maneuver description.

- ~~“NO” designates that this described maneuver shall be interpreted as being the aggregated/total composite maneuver and that no other additive maneuver constituents are to be added to it.~~

~~6.2.8.10.1~~ The message recipient should exercise caution whenever maneuvers are additive (MAN_IS_ADDITIVE=YES), to prevent the unintentional accumulation of maneuver contributions, for example across disparate orbit determination solutions (MAN_OD_ID).

~~6.2.8.11~~6.2.7.9 Each maneuver data block should ~~be be unique~~differ from all other maneuver data blocks in at least one of the following respects:

- 1) the maneuver device ID (MAN_DEVICE_ID) is unique
- 2) the maneuver device ID is the same, but the “ON” time intervals are unique and do not overlap with any other data interval(s) for this maneuver device ID (e.g., during multiple interleaved duty cycle “ON” firings).
- 3) the maneuver basis (MAN_BASIS) is unique
- 4) the reference frame is unique (MAN_REF_FRAME)
- ~~5) the orbit center is unique (MAN_CENTER_NAME)~~
- ~~6) 5) _____~~ the maneuver is based upon a unique orbit determination, navigation solution, or simulation (e.g., MAN_OD_BASIS_ID)
- ~~7) 6) _____~~ the data interval timespan is unique (i.e., has no overlap)

~~6.2.8.12~~6.2.7.10 In the event that the only difference between multiple maneuver time history data blocks is the selected maneuver composition (MAN_COMPOSITION), or reference frame (MAN_REF_FRAME) and/or maneuver orbit center (MAN_CENTER_NAME), the top-most depiction (i.e., the time history occurring first in the OCM) shall be adopted as the ~~true or master~~official depiction, and those subsequent data blocks shall be treated as containing informational derivative depictions ~~provided purely for informational purposes~~.

~~6.2.8.13~~ The message creator shall specify the maneuver time history elements of information (**MAN_COMPOSITION**) to follow the maneuver time tag (in absolute or relative time, as discussed above) on each maneuver time history line, stipulated in comma delimited format from an ordered combination of the options shown in Table 6-8. ~~composition~~

~~6.2.8.14~~ The **MAN_COMPOSITION** keyword shall specify the elements of information to be provided on each maneuver time history line, which shall be selected from one or more elements of **Table 6-8** (for thrust, acceleration, and/or velocity increments imparted by any/all thrusters and/or other perturbative forces) and **Table 6-9** (for deployment-induced orbit changes). The order of these elements shall retain the ordering shown in Table 6-8 and Table 6-9, which are alphabetized by broad category but not by subcategory):

~~Table 6-8: OCM Data: Selectable propulsive (i.e., non-deployment) maneuver fields in the maneuver time history data~~

Keyword	Description	Units	Examples of Values
MAN_DURA	The maneuver duration associated with this impulsive ΔV, thrust, and/or acceleration imparted event.	s	200.0
ACC_X	Acceleration component A_x in the selected maneuver frame	km/s²	.01
ACC_Y	Acceleration component A_y in the selected maneuver frame	km/s²	.02
ACC_Z	Acceleration component A_z in the selected maneuver frame	km/s²	.03
ACC_INTERP	Acceleration vector Euler axis/angle interpolation mode between current and next acceleration line	n/a	OFF ON
ACC_DMASS	Additional mass change (where a negative number denotes a mass decrement/loss to the host) associated with this acceleration interval	kg	-5.0
ACC_SIGMA	One-sigma percent error on acceleration magnitude	%	1.0
DV_X	Velocity increment ΔV_x in the selected maneuver reference frame. The actual ΔV should be impulsively applied at a time of <time tag> + ½ (MAN_DURA).	km/s	1.0
DV_Y	Velocity increment ΔV_y in the selected maneuver reference frame. The actual ΔV should be impulsively applied at a time of <time tag> + ½ (MAN_DURA).	km/s	2.0
DV_Z	Velocity increment ΔV_z in the selected maneuver reference frame. The actual ΔV should be impulsively applied at a time of <time tag> + ½ (MAN_DURA).	km/s	3.0
DV_DMASS	The mass change to the host (where a NEGATIVE VALUE denotes a mass decrement/loss) associated with this ΔV event	kg	-1.0
DV_SIGMA	One-sigma percent error on ΔV magnitude	%	2.0
THR_X	Thrust component T_x measured in the selected maneuver reference frame	N	1.0
THR_Y	Thrust component T_y measured in the selected maneuver reference frame	N	2.0
THR_Z	Thrust component T_z measured in the selected maneuver reference frame	N	3.0
THR_DMASS	Additional mass change (where a negative number denotes a mass decrement/loss to the host) associated with this thrust interval, beyond the mass change already prescribed by the rocket equation	kg	-5.0
THR EFFIC	Thrust efficiency “η” ranging between 0.0 and 1.0	n/a	0.95
THR_INTERP	Thrust vector Euler axis/angle interpolation mode between current and next thrust line; values shall be selected as either “OFF” or “ON”.	n/a	OFF ON
THR_ISP	Thrust specific impulse	s	330.0

Keyword	Description	Units	Examples of Values
THR_SIGMA	One-sigma-percent error on thrust magnitude	%	2.0

~~Table 6-9: OCM Data: Selectable deployment fields in the maneuver time history data~~

Keyword	Description	Units	Examples of Values
DEPLOY_ID	Free-text identifier of the resulting “child” object deployed from this host during TIME_SPAN. Setting DEPLOY_ID to zero “0” indicates that a deployment did not occur at this time tag.	n/a	CubeSat_001
DEPLOY_DV_X	Velocity increment ΔV_x of the deployed “child” object measured in the selected maneuver reference frame, applied instantaneously at the time tag of deployment.	km/s	1.0
DEPLOY_DV_Y	Velocity increment ΔV_y of the deployed “child” object measured in the selected maneuver reference frame, applied instantaneously at the time tag of deployment.	km/s	2.0
DEPLOY_DV_Z	Velocity increment ΔV_z of the deployed “child” object measured in the selected maneuver reference frame, applied instantaneously at the time tag of deployment.	km/s	3.0
DEPLOY_MASS	Decrement in host mass as a result of deployment (shall be ≤ 0.0)	kg	-1.0
DEPLOY_DV_SIGMA	One-sigma-percent error on deployment ΔV magnitude	%	5.0
DEPLOY_DV_RATIO	Ratio of child-to-host ΔV vectors, such that: $\overline{\Delta v}_{host} = \text{DEPLOY_DV_RATIO} \times \overline{\Delta v}_{child}$ <p>NOTE: Since an opposite ΔV direction typically occurs, this number is typically less than or equal to zero. This ratio allows the user to specify what ΔV impacts the host vehicle. This is usually not -1.0 (i.e. an equal-and-opposite imparted velocity), to account for the mass fraction between the child and the host as well as any rotational torque acted upon the host due to any offsets between the deployment direction centerline and the host’s center of gravity.</p>	n/a	-0.05
DEPLOY_DV_CDA	Typical (50 th percentile) product of drag coefficient (Cd) times cross-sectional area for the deployed “child” object	m**2	0.022

6.2.7.11 The MAN COMPOSITION keyword shall specify the individual maneuver time history elements to follow the maneuver time tag.

NOTE 1: Specification of a time history of acceleration parameters ACC_X, ACC_Y, and ACC_Z allows the OCM originator to portray and share the net effects of maneuvers without the OCM recipient needing to do complex finite burn modeling.

NOTE 2: Specification of ΔV parameters allows modeling of impulsive (instantaneous velocity change) maneuvers.

NOTE 3: Specification of thrust parameters provides a finite burn capability. In the case of low-thrust and/or long-duration burns, sequential low-thrust interval maneuver lines can be used to reflect the evolution of the low-thrust maneuver thrust parameters.

6.2.7.12 The MAN_COMPOSITION keyword shall contain a comma-separated list of values taken from either Table 6-8 or Table 6-9 (i.e., values from both tables Table 6-8 and Table 6-9 shall not be combined within a single maneuver data block).

6.2.7.13 The values contained in the MAN_COMPOSITION keyword shall appear in the order fixed in either Table 6-8 or Table 6-9.

6.2.8.14.16.2.7.13.1 Maneuver time history lines shall be confined to only one ~~host/parent~~ spacespacecraft object.

6.2.8.15 Maneuver time history lines shall begin with the time tag of the **start** of the maneuver event (T_{start}). Time tags may be specified as either a **relative time** (e.g., 20157.26) measured in seconds with respect to the epoch time specified via the EPOCH_TZERO keyword **or an absolute time** (e.g., 2018-11-13T11:13:20.5Z as formatted in Section 7.5.10) epoch time.

6.2.7.14 At least one of the time tag formats shall be selected in the MAN_COMPOSITION specification (TIME_ABSOLUTE and/or TIME_RELATIVE).

6.2.8.15.16.2.7.15 Within a single maneuver time history line, acceleration, impulsive ΔV , and thrust parameters shall not be additive, but rather shall be interpreted as alternate representations of the same underlying propulsive phenomenology. ~~For this reason, impulsive ΔV events shall applied at a time tag of $T_{start} + \frac{1}{2}(MAN_DURA)$.~~

6.2.7.16 NOTE 1: ~~This interpretation requires that the time~~ Time tag associated with (s) on each maneuver line applies shall be considered to be at the start of the maneuver, and that whereas impulsive ΔV representations entries in the propulsive representation (Table 6-8) need to shall be applied interpreted as occurring at a time tag of $T_{start} + \frac{1}{2}(MAN_DURA)$.

NOTE 2: While one could artificially make T_{start} and the impulsive maneuver time be the same value by setting MAN_DURA equal to zero, ~~this practice is discouraged because even when a maneuver is approximated by a ΔV impulse, the the actual~~ duration of the maneuver is typically not zero, and the actual MAN_DURA duration greatly aids in nonzero and should be provided if/when known to facilitate improved modeling and reconstructing the maneuver reconstruction.

NOTE 3: ~~Specification of a time history of acceleration parameters ACC_X, ACC_Y, and ACC_Z allows modeling of both individual and aggregate maneuvers and any additional non-conservative perturbations that are not already specified in the “OCM Perturbations Specification” section or other maneuver time histories (including thrust/ ΔV /acceleration alternate portrayals). This allows the OCM originator to model and share the effects of maneuver and perturbations information without the OCM recipient needing to do such modeling.~~

~~NOTE 4: It is recommended that acceleration parameter portrayals of additional non-conservative perturbations avoid intermixing thrust or impulsive ΔV alternate portrayals, since such thrust or ΔV specifications on the same line may be inconsistent with the accompanying acceleration parameters.~~

~~6.2.8.16 Specification of **ΔV parameters** allows modeling of impulsive maneuvers, i.e., maneuvers where the space object's velocity is instantaneously changed. Impulsive ΔV events shall applied at a time tag of $T_{\text{start}} + \frac{1}{2}(\text{MAN_DURA})$.~~

~~NOTE: While such impulsive maneuvers are modeled as instantaneous velocity changes, they can and should be accompanied by the actual duration of the maneuver if/when known.~~

~~6.2.8.16.1 Specification of **thrusting parameters** provides a finite burn capability. In the case of low thrust, long duration burns, sequential low thrust interval maneuver lines can be used to reflect the evolution of the low thrust maneuver thrust parameters.~~

~~6.2.8.16.2 Multiple thruster maneuver contributions shall only be represented as separate maneuver time history data blocks.~~

~~6.2.7.16.1 Thrust~~When invoked, interpolation of acceleration (ACC_INTERP=ON) and/or thrust vectors (THR_INTERP=ON) shall be done using a suitable interpolation scheme such as the Euler axis/angle formulation discussed in Annex section C5.

~~6.2.8.16.36.2.7.16.2~~ Thrust and acceleration levels for any propulsive device shall be presumed to be "OFF" until explicitly turned "ON" by setting one or more ~~of that thruster's maneuver thrust~~ or acceleration components (THR_X, THR_Y, and/or THR_Z) to a non-zero value.

~~6.2.8.16.46.2.7.16.3~~ Thrusters Thrust and acceleration shall be set back to "OFF" after the time surpasses maneuver duration has elapsed [$T_{\text{start}} + \text{MAN_DURA}$]. Thrusters may also be subsequently turned "OFF" by setting all ~~of that thruster's maneuver thrust~~ and acceleration components to zero (i.e., THR_X = THR_Y = THR_Z = 0.0).

~~6.2.7.16.4~~ Thruster duty cycles ~~may~~shall be specified using the ~~thrusting~~thrust maneuver specification (DUTY_CYCLEDC_TYPE \neq CONTINUOUS) based on either a reference direction or reference time.

~~6.2.8.16.5~~ NOTE: This duty cycle specification imposes cut-outs of non-~~thrusting~~thrust periods onto the thrustingthrust (finite burn) parameters to reflect the periods of duty cycle inactivity.

~~6.2.7.16.5~~ When a duty cycle is invoked, ~~specification of~~ the ~~reference direction, reference time and any/all other~~ value of the DC TYPE keyword is not CONTINUOUS, then the following duty cycle parameters ~~relevant to that duty cycle type~~ shall be present:

~~6.2.7.16.5.1~~ If the value is ~~mandatory~~ TIME, then DC_WIN_OPEN, DC_WIN_CLOSE, DC EXEC START, DC EXEC STOP, DC REF TIME, DC TIME PULSE DURATION, and DC TIME PULSE PERIOD shall be present.

~~6.2.8.16.66.2.7.16.5.2~~ If the value is TIME AND ANGLE, then DC_WIN_OPEN, DC_WIN_CLOSE, DC EXEC START, DC EXEC STOP, DC REF TIME, DC TIME PULSE DURATION, and DC TIME PULSE PERIOD, DC REF DIR, DC BODY TRIGGER, DC PA START ANGLE, and DC PA STOP ANGLE shall be present.

~~6.2.8.16.76.2.7.16.6~~ Optionally, “DC_MIN_CYCLES” and “DC_MAX_CYCLES” may be specified to constrain the number of duty cycles performed: in either TIME or TIME AND ANGLE mode. These parameters may override the duty cycle maneuver stop time (DC_EXEC_STOP).

NOTE 1: Relationships between such duty cycle parameters ~~is~~are described in ANNEX C, Section C3.

NOTE 2: The effects of using a pulse width modulation thruster controller can be accommodated by applying a reduced constant thrust level or by invoking the duty cycle parameters, or a combination thereof (being careful to avoid double-booking of thruster degradations).

Table 6-7: OCM Data: Maneuver Specification

Keyword	Description	Units	Default (if any)	Examples of Values	Mandatory M/O/ C
MAN_START	Start of a maneuver data block specification .	n/a			Yes M
COMMENT	Comments (a contiguous set of one or more comment lines is allowed in the OCM Maneuver Specification only immediately after the MAN_START key word; see 7.7 for comment formatting rules).	n/a		This is a comment	No O
MAN_ID	Optional MANDATORY alphanumeric free-text string containing the <u>unique maneuver identification number for this maneuver</u> . <u>All supplied maneuver “constituents” within the same MAN BASIS and MAN REF FRAME categories shall be added together to represent the total composite maneuver description</u> .	n/a		E_W_20160305B <u>STAGE2</u>	No M

CCSDS PROPOSED STANDARD FOR ORBIT DATA MESSAGES

Keyword	Description	Units	Default (if any)	Examples of Values	Mandatory M/O/ C
MAN_PREV_ID	Optional alphanumeric free-text string containing the identification number of the previous maneuver for this MAN_BASIS. Note: if the message is not part of a sequence of maneuver messages or if this maneuver is the first in a sequence of maneuvers, then MAN_PREV_ID should be excluded from this message.	n/a		E_W_20160305A	No Q
MAN_NEXT_ID	Optional alphanumeric free-text string containing the identification number of the next maneuver for this MAN_BASIS. Note: if the message is not part of a sequence of maneuver messages or if this maneuver is the last in a sequence of maneuvers, then MAN_NEXT_ID should be excluded from this message.	n/a		E_W_20160305C	No Q
MAN_BASIS	Basis of this maneuver time history data, which shall be selected from one of the following values: <ol style="list-style-type: none"> 1. "CANDIDATE" for a proposed operational or a hypothetical (i.e., mission design and optimization studies) future maneuver 2. "PLANNED" for a currently planned future maneuver 3. "ANTICIPATED" for a non-cooperative future maneuver that is anticipated (i.e. likely) to occur (e.g., based upon patterns-of-life analysis). 4. "DETERMINED_TLM" when a past maneuver is determined from propulsion and attitude system telemetry in near-real-time for reconstruction 5. "DETERMINED_OD" when a past maneuver is estimated from observation-based orbit determination reconstruction and/or calibration. 	n/a	PLANNED	DETERMINED_TLM CANDIDATE	No Q
MAN_ OD BASIS_ID	Optional alphanumeric free-text string containing the identification number of for the orbit determination, <u>navigation solution, or simulation</u> upon which this maneuver data time history block is based. <u>Where a matching orbit determination block accompanies this maneuver time history, the MAN_BASIS_ID should match the corresponding OD_ID.</u>	n/a		OD_20181122A	No Q
MAN_DEVICE_ID	MANDATORY Alphanumeric free-text string containing the maneuver device Identifier used for this maneuver. "ALL" indicates that this maneuver represents the summed acceleration (or, velocity increment), or thrust imparted by any/all thrusters utilized in the maneuver.	n/a		ALL THR_02 DEPLOYMENT	Yes M

CCSDS PROPOSED STANDARD FOR ORBIT DATA MESSAGES

Keyword	Description	Units	Default (if any)	Examples of Values	Mandatory M/O/C
MAN_IS_ADDITIVE	Specifies (by either YES or NO) whether this maneuver is additive with other specified time-overlapping maneuvers when they share the same maneuver basis (MAN_BASIS) . If "YES", then this maneuver is combined with all other maneuvers where MAN_IS_ADDITIVE is set to "YES". Note that if "NO" is selected, such time-overlapping maneuvers are to be interpreted as being multiple approaches to characterize the same composite (total) maneuver profile.	n/a	NO	YES NO	Yes (defaults to "NO")
MAN_PREV_TIMEEPOCH	Identifies the completion time of the previous maneuver for this MAN_BASIS. This time may be specified as either "YYY", where "YYY" contains relative time in seconds (relative to EPOCH_TZERO), or "<epoch>" (see 7.5.10 for formatting rules).	n/a		50.0 2001-11-06T11:17:33 2002-204T15:56:23Z	NeO
MAN_NEXT_TIMEEPOCH	Identifies the start time of the next maneuver for this MAN_BASIS. This time may be specified as either "YYY", where "YYY" contains relative time in seconds (relative to EPOCH_TZERO), or "<epoch>" (see 7.5.10 for formatting rules).	n/a		50.0 2001-11-06T11:17:33 2002-204T15:56:23Z	NeO
MAN_PURPOSE	The user can specify the intention(s) of the maneuver. Multiple maneuver purposes can be provided as a comma-delimited list. While there is no CCSDS-based restriction on the value for this free-text keyword, it is suggested to use: Aerobraking (AEROBRAKE), Attitude adjust (ATTITUDE) Collision avoidance (COLA) Deployment (DEPLOY) Disposal (DISPOSAL) Gravity assist flyby (GRAV_ASSIST_FROM_XXXX, where XXXX=body center name, e.g.,SANA Registry [12] [11]) Inclination adjustment (INCLINATION) Launch & Early Orbit (LEOP) Maneuver cleanup (MNVR_CLEANUP) Mass adjust (MASS_ADJUST) Momentum desaturation (MOM_DESAT) Orbit adjust (ORBIT) Orbit trim (TRIM) Other (OTHER) Period adjustment (PERIOD) Pointing Request Message (PRM_ID_xxxx) Relocation (RELOCATION) Science objective (SCI_OBJ) Spin rate adjust (SPIN_RATE) Station-keeping (SK) Trajectory correction (TRAJ_CORR)	n/a		DISPOSAL	NeO

CCSDS PROPOSED STANDARD FOR ORBIT DATA MESSAGES

Keyword	Description	Units	Default (if any)	Examples of Values	Mandatory M/O/ C
MAN_COMPOSITION	The comma-delimited ordered set of maneuver elements of information to follow the maneuver time tag (relative or absolute time, as discussed above) on every maneuver time history line, with values selected from Table 6-8 or Table 6-9.	n/a		THR_X, THR_Y, THR_Z, THR_ISP, THR_EFFIC, THR_DMSS, DV_X, DV_Y, DV_Z	Yes
MAN_PRED_SOURCE	For future maneuvers, specifies the source of the orbit and/or attitude state(s) upon which the maneuver is based. While there is no CCSDS-based restriction on the value for this free-text keyword, it is suggested to consider using ORB_ID and OD_ID keywords as described in Tables 6-4 and 6-11 respectively, or a combination thereof.	n/a		OD_5	No
MAN_CENTER_NAME	Origin of the maneuver reference frame, which may be a natural solar system body (planets, asteroids, comets, and natural satellites), including any planet barycenter or the solar system barycenter, or another reference frame center (such as a spacecraft, ground station, formation flying reference "chief" spacecraft, etc.). Natural bodies shall be selected from the accepted set of values indicated in ANNEX B, Section B2. For spacecraft, it is recommended to use either the Object name or international designator of the participant as catalogued in the UN Office of Outer Space Affairs designator index (reference [2]). Alternately, the OBJECT_DESIGNATOR may be used. For other reference frame origins, this field is a free text descriptor which can draw upon ground station name, etc.	n/a	EARTH	EARTH MOON SOLAR-SYSTEM BARYCENTER SUN ISS EROS EARTH_SUN_L2	No
MAN_REF_FRAME	Reference frame in which the maneuver vector direction data is provided, if not intrinsic to the definition of the in this maneuver data block. Select from the accepted set of values indicated in ANNEX B, Section B4. The reference frame must be the same for all data elements within a given Maneuver Time History block.	n/a	TNW_I NERTIA L	J2000	No
MAN_FRAME_EPOCH	Epoch of the maneuver data reference frame, if not intrinsic to the definition of the reference frame. See 7.5.10 for formatting rules.	n/a		2001-11- 06T11:17:33 2002- 204T15:56:23Z	No

CCSDS PROPOSED STANDARD FOR ORBIT DATA MESSAGES

Keyword	Description	Units	Default (if any)	Examples of Values	Mandatory M/O/C
GRAV_ASSIST_NAME	Origin of maneuver gravitational assist body, which may be a natural solar system body (planets, asteroids, comets, and natural satellites), including any planet barycenter or the solar system barycenter. See ANNEX B, Section B2, for acceptable GRAV_ASSIST_NAME values (and the procedure to propose new values).	n/a	EARTH	EARTH MOON SOLAR-SYSTEM BARYCENTER SUN EROS EARTH-SUN-L2JUPITER	NoC
DUTY_CYCLEDC_TYPE	Specifies the type of duty cycle type to use for this maneuver time history section: <ul style="list-style-type: none"> CONTINUOUS denotes full/continuous thrust; TIME denotes a time-based duty cycle driven by time past a reference time and the duty cycle ON and OFF durations; PHASETIME AND ANGLE denotes a duty cycle driven by the phasing/clocking of a space object body frame "trigger" direction past a reference direction. 	n/a	CONTINUOUS	CONTINUOUS TIME PHASE_ANGLE	NoC
DC_WIN_OPEN	For ALL duty cycle types, specifies the start time of the duty cycle-based maneuver window that occurs on or prior to the actual maneuver execution start time. For example, this may identify the time at which the satellite is first placed into a special duty-cycle-based maneuver mode. This start time may be specified as either "YYY", where "YYY" contains relative time in seconds (relative to EPOCH_TZERO), or "<epoch>" (see 7.5.10 for formatting rules). This value is mandatory shall be provided if DUTY_CYCLEDC_TYPE ≠ "CONTINUOUS".	n/a		50.0 2001-11-06T11:17:33 2002-204T15:56:23Z	NoC
DC_WIN_CLOSE	Specifies For ALL duty cycle types, the end time of the duty cycle-based maneuver window that occurs on or after the actual maneuver execution end time. For example, this may identify the time at which the satellite is taken out of a special duty-cycle-based maneuver mode. This end time may be specified as either "YYY", where "YYY" contains relative time in seconds (relative to EPOCH_TZERO), or "<epoch>" (see 7.5.10 for formatting rules). This value is mandatory shall be provided if DUTY_CYCLEDC_TYPE ≠ "CONTINUOUS".	n/a		100.0 2001-11-07T51:17:33 2002-204T15:58:03Z	NoC

CCSDS PROPOSED STANDARD FOR ORBIT DATA MESSAGES

Keyword	Description	Units	Default (if any)	Examples of Values	Mandatory M/O/C
DC_MIN_CYCLES	Minimum For ALL duty cycle types, the minimum number of "ON" duty cycles (may override DC_EXEC_STOP). This value is optional even if DC_TYPE ≠ "CONTINUOUS".	n/a	0	5	No <u>C</u>
DC_MAX_CYCLES	Maximum For ALL duty cycle types, the maximum number of "ON" duty cycles (may override DC_EXEC_STOP). This value of zero disables this limit- is optional even if DC_TYPE ≠ "CONTINUOUS".	n/a	(unlimited) 0	200	No <u>C</u>
DC_EXEC_START	The specified For ALL duty cycle types, start time of the initial duty cycle-based maneuver sequence execution. DC_EXEC_START is defined to occur on or prior to the first maneuver "ON" portion within the duty cycle sequence. DC_EXEC_START must occur coincident with or after DC_WIN_OPEN. This maneuver execution start time may be specified as either "YYY", where "YYY" contains relative time in seconds (relative to EPOCH_TZERO), or "<epoch>" (see 7.5.10 for formatting rules). This value is mandatory shall be provided if DUTY_CYCLE DC_TYPE ≠ "CONTINUOUS".	n/a		50.0 2001-11-06T11:17:33 2002-204T15:56:23Z	No <u>C</u>
DC_EXEC_STOP	The specified For ALL duty cycle types, end time of the final duty cycle-based maneuver sequence execution. DC_EXEC_STOP typically occurs on or after the end of the final maneuver "ON" portion within the duty cycle sequence. DC_EXEC_STOP occurs prior to or coincident with DC_WIN_CLOSE. This maneuver execution end time may be specified as either "YYY", where "YYY" contains relative time in seconds (relative to EPOCH_TZERO), or "<epoch>" (see 7.5.10 for formatting rules). This value is mandatory shall be provided if DUTY_CYCLE DC_TYPE ≠ "CONTINUOUS".	n/a		100.0 2001-11-07T51:17:33 2002-204T15:58:03Z	No <u>C</u>
DC_REF_TIME	Specifies For ALL duty cycle types, the THRUST duty cycle reference time tag as either "YYY", where "YYY" contains relative time in seconds (relative to EPOCH_TZERO), or "<epoch>" (see 7.5.10 for formatting rules). Note: Depending upon -EPOCH_TZERO, DC_REF_TIME relative times may be negative. This value is mandatory shall be provided if DUTY_CYCLE DC_TYPE ≠ "CONTINUOUS" <u>TIME</u> .	n/a		8000.0 2001-11-06T11:17:33	No <u>C</u>

CCSDS PROPOSED STANDARD FOR ORBIT DATA MESSAGES

Keyword	Description	Units	Default (if any)	Examples of Values	Mandatory M/O/ C
DC_TIME_PULSE_DURATION	<p>For time-based thrusterALL duty cycle (DUTY_CYCLE_TYPE=TIME), types, specifies thruster pulse "ON" duration, initiated at first satisfaction of the burn "ON" time constraint or upon completion of the previous DC_TIME_PULSE_PERIOD cycle.</p> <p>This value is mandatoryshall be provided if DUTY_CYCLEDC_TYPE ≠ "CONTINUOUS TIME".</p>	s		10.0	No C
DC_TIME_PULSE_PERIOD	<p>For time-based thrusterALL duty cycle (DUTY_CYCLE_TYPE=TIME), types, specifies the elapsed time between the start of one pulse and the start of the next. Must be greater than or equal to DC_TIME_PULSE_DURATION.</p> <p>This value is mandatoryshall be provided if DUTY_CYCLEDC_TYPE ≠ "CONTINUOUS TIME".</p>	s		200.0	No C
DC_REF_DIR	<p>For phase angle thruster duty cycles (DUTY_CYCLE DC_TYPE=PHASE TIME AND ANGLE), specifies the "ON" reference unit vector direction in the "MAN_REF_FRAME" reference frame (i.e., at which, when mapped into the start of space object's spin plane (normal to the spin axis) the duty cycle "ON" and is triggered (see DC_PA_START_ANGLE for phasing).</p> <p>This (tripartite, or three-element vector) value shall be provided if DC_TYPE = "TIME AND ANGLE".</p> <p>This reference direction does NOT represent the duty cycle midpoint).</p> <p>This value is mandatory if DUTY_CYCLE_TYPE = "PHASE_ANGLE".</p>	n/a		1.0 0.0 0.0	No C
DC_BODY_TRIGGER	<p>SpecifiesFor phase angle thruster duty cycles (DC_TYPE=TIME AND ANGLE), specifies the body frame reference unit vector direction at which, when the its projection is aligned with onto the spin plane crosses the corresponding projection of DC_REF_DIR direction, initiates thrusting when both are projected into onto the spin plane., this angle-based duty cycle is initiated (see DC_PA_START_ANGLE for phasing).</p> <p>This tripartite value is mandatoryshall be provided if DUTY_CYCLEDC_TYPE = "PHASE TIME AND ANGLE".</p>	n/a		.707 0.0 .707	No C

CCSDS PROPOSED STANDARD FOR ORBIT DATA MESSAGES

Keyword	Description	Units	Default (if any)	Examples of Values	Mandatory M/O/ C
DC_PA_START_ANGLE	<p>PhaseFor phase angle thruster duty cycles (DC_TYPE=TIME AND ANGLE), specifies the <u>phase</u> angle offset of thruster pulse start, measured with respect to the occurrence of a DC_BODY_TRIGGER crossing of the DC_REF_DIR direction when both are projected into the spin plane (normal to the body spin axis). DC_PA_START can be positive or negative to allow the duty cycle to begin prior to the next crossing of the DC_REF_DIR. As this angular direction is to be used in a modulo sense, there is no requirement for the magnitude of DC_PA_START to be less than 360.</p> <p>This value is mandatoryshall be provided if <u>DUTY_CYCLE</u>DC_TYPE = "PHASETIME AND ANGLE".</p>	deg		25.0	No C
DC_PA_STOP_ANGLE	<p>PhaseFor phase angle thruster duty cycles (DC_TYPE=TIME AND ANGLE), specifies the <u>phase</u> angle of thruster pulse stop, measured with respect to the DC_BODY_TRIGGER crossing of the DC_REF_DIR direction when both are projected into the spin plane. DC_PA_STOP can be positive or negative to allow the duty cycle to end after to the next crossing of the DC_REF_DIR. As this angular direction is to be used in a modulo sense, there is no requirement for the magnitude of DC_PA_STOP to be less than 360.</p> <p>This value is mandatoryshall be provided if <u>DUTY_CYCLE</u>DC_TYPE = "PHASETIME AND ANGLE".</p>	deg		35.0	No C
<u>MAN_COMPOSITION</u>	<p>The comma-delimited ordered set of maneuver elements of information to follow the <u>maneuver time tag (relative or absolute time, as discussed above) on every maneuver time history line, with values selected from Table 6-8 or Table 6-9.</u></p>			<p><u>THR X, THR Y, THR Z, THR ISP, THR EFFIC, DELTA MASS, DV X, DV Y, DV Z, DV SIGMA</u></p>	<u>M</u>
<p>... < Insert maneuver lines here >MAN_UNITS</p>	<p>Maneuver time history data/content shall be provided as described above.A comma-delimited set of SI unit designations for each and every element of the maneuver time history <u>after the maneuver time tag shall be provided in aggregate as an alphanumeric free-text string enclosed in square brackets. All elements comprising the MAN_COMPOSITION must have a corresponding units entry; percentages shall be denoted by "%" and control switches, non-dimensional values and text strings shall be labelled as "nd". Suggested units are provided in Table 6-8 and Table 6-9.</u></p>			<p>[N,N,N,s,%,kg,m/s, m/s,m/s, %,nd]</p>	Yes M

CCSDS PROPOSED STANDARD FOR ORBIT DATA MESSAGES

Keyword	Description	Units	Default (if any)	Examples of Values	Mandatory <u>M/O/C</u>
<u>... < Insert maneuver data here></u>	<u><Maneuver time history data, content, and units shall be provided as specified by MAN_COMPOSITION.></u>				<u>M</u>
MAN_STOP	End maneuver data block specification.	n/a			Yes <u>M</u>

Table 6-8: OCM Data: Selectable propulsive (i.e., non-deployment) maneuver fields in the maneuver time history data

<u>Keyword</u>	<u>Description</u>	<u>Units</u>	<u>Examples of Values</u>
<u>TIME_ABSOLUTE</u>	<u>Absolute epoch time as formatted in Section 7.5.10.</u>	<u>s</u>	<u>2018-11-13T11:13:20.5Z</u>
<u>TIME_RELATIVE</u>	<u>Relative epoch time measured in seconds with respect to the epoch time specified via the EPOCH_TZERO keyword.</u>	<u>s</u>	<u>20157.26</u>
<u>MAN_DURA</u>	<u>The maneuver duration associated with this impulsive ΔV, thrust, and/or acceleration-imparted event.</u>	<u>s</u>	<u>200.0</u>
<u>DELTA_MASS</u>	<u>Mass change (where a negative number denotes a mass decrement/loss to the host) associated with this time interval. For “thrust” specification, this mass change shall include the mass change prescribed by the rocket equation.</u>	<u>kg</u>	<u>-5.0</u>
<u>ACC_X</u>	<u>Acceleration component A_x in the selected maneuver frame.</u>	<u>km/s** <u>2</u></u>	<u>0.000734092785</u>
<u>ACC_Y</u>	<u>Acceleration component A_y in the selected maneuver frame.</u>	<u>km/s** <u>2</u></u>	<u>0.000189779834</u>
<u>ACC_Z</u>	<u>Acceleration component A_z in the selected maneuver frame.</u>	<u>km/s** <u>2</u></u>	<u>0.0000794872502</u>
<u>ACC_INTERP</u>	<u>Acceleration vector Euler axis/angle interpolation mode between current and next acceleration line.</u>	<u>n/a</u>	<u>OFF ON</u>
<u>ACC_SIGMA</u>	<u>One-sigma percent error on acceleration magnitude.</u>	<u>%</u>	<u>1.0</u>
<u>DV_X</u>	<u>Velocity increment ΔV_x in the selected maneuver reference frame. The actual ΔV should be impulsively applied at a time of <time tag> + $\frac{1}{2}$ (MAN_DURA).</u>	<u>km/s</u>	<u>0.025</u>
<u>DV_Y</u>	<u>Velocity increment ΔV_y in the selected maneuver reference frame. The actual ΔV should be impulsively applied at a time of <time tag> + $\frac{1}{2}$ (MAN_DURA).</u>	<u>km/s</u>	<u>0.0015</u>
<u>DV_Z</u>	<u>Velocity increment ΔV_z in the selected maneuver reference frame. The actual ΔV should be impulsively applied at a time of <time tag> + $\frac{1}{2}$ (MAN_DURA).</u>	<u>km/s</u>	<u>0.00029</u>
<u>DV_SIGMA</u>	<u>One-sigma percent error on ΔV magnitude.</u>	<u>%</u>	<u>2.0</u>
<u>THR_X</u>	<u>Thrust component T_x measured in the selected maneuver reference frame.</u>	<u>N</u>	<u>1.0</u>
<u>THR_Y</u>	<u>Thrust component T_y measured in the selected maneuver reference frame.</u>	<u>N</u>	<u>2.0</u>
<u>THR_Z</u>	<u>Thrust component T_z measured in the selected maneuver reference frame.</u>	<u>N</u>	<u>3.0</u>
<u>THR_EFFIC</u>	<u>Thrust efficiency “η” ranging between 0.0 and 1.0.</u>	<u>n/a</u>	<u>0.95</u>
<u>THR_INTERP</u>	<u>Thrust vector Euler axis/angle interpolation mode between current and next thrust line; values shall be selected as either “OFF” or “ON”.</u>	<u>n/a</u>	<u>OFF ON</u>
<u>THR_ISP</u>	<u>Thrust specific impulse.</u>	<u>s</u>	<u>330.0</u>
<u>THR_SIGMA</u>	<u>One-sigma percent error on thrust magnitude.</u>	<u>%</u>	<u>2.0</u>

Table 6-9: OCM Data: Selectable deployment fields in the maneuver time history data

<u>Keyword</u>	<u>Description</u>	<u>Units</u>	<u>Examples of Values</u>
<u>TIME_ABSOLUTE</u>	Absolute epoch time as formatted in Section 7.5.10.	s	<u>2018-11-13T11:13:20.5Z</u>
<u>TIME_RELATIVE</u>	Relative epoch time measured in seconds with respect to the epoch time specified via the EPOCH_TZERO keyword.	s	<u>20157.26</u>
<u>DEPLOY_ID</u>	Free-text identifier of the resulting “child” object deployed from this host during TIME_SPAN. Setting DEPLOY_ID to zero “0” indicates that a deployment did not occur at this time tag.	n/a	<u>CubeSat_001</u>
<u>DEPLOY_DV_X</u>	Velocity increment ΔV_x of the deployed “child” object measured in the selected maneuver reference frame, applied instantaneously at the time tag of deployment.	km/s	<u>0.0001</u>
<u>DEPLOY_DV_Y</u>	Velocity increment ΔV_y of the deployed “child” object measured in the selected maneuver reference frame, applied instantaneously at the time tag of deployment.	km/s	<u>0.00003</u>
<u>DEPLOY_DV_Z</u>	Velocity increment ΔV_z of the deployed “child” object measured in the selected maneuver reference frame, applied instantaneously at the time tag of deployment.	km/s	<u>0.00002</u>
<u>DEPLOY_MASS</u>	Decrement in host mass as a result of deployment (shall be ≤ 0.0).	kg	<u>-1.0</u>
<u>DEPLOY_DV_SIGMA</u>	One-sigma percent error on deployment ΔV magnitude.	%	<u>5.0</u>
<u>DEPLOY_DV_RATIO</u>	Ratio of child-to-host ΔV vectors, such that: $\overline{\Delta v}_{host} = \text{DEPLOY_DV_RATIO} \times \overline{\Delta v}_{child}$ <p>NOTE: As an opposite ΔV is typically imparted to the host during deployment, this number is typically less than or equal to zero. This ratio allows the user to specify how much ΔV is imparted to the host vehicle. This is usually not -1.0 (i.e. an equal-and-opposite imparted velocity), to account for the mass fraction between the child and the host as well as any rotational torque acted on the host as a result of deployment direction centerline offsets as compared to the host’s center of gravity.</p>	n/a	<u>-0.05</u>
<u>DEPLOY_DV_CDA</u>	Typical (50 th percentile) product of drag coefficient (Cd) times cross-sectional area for the deployed “child” object.	m**2	<u>0.022</u>

6.2.96.2.8 OCM DATA: PERTURBATIONS SPECIFICATION

Table 6-10

Table 6-10 provides an overview of the OCM Perturbations Specification section. Only those keywords shown in **Table 6-10**

6.2.9.16.2.8.1 **Table 6-10** shall be used in OCM perturbations specification.

6.2.9.26.2.8.2 Only one OCM Perturbations Specification section shall appear in an OCM.

6.2.9.36.2.8.3 The OCM Perturbations Specification section shall be delimited by two keywords: PERT_START and PERT_STOP.

~~6.2.9.4 The gravity model (GRAVITY_MODEL) degree (D) and order (O) of the spherical harmonic coefficients applied should be given along with the name of the model. Note that specifying a zero value for “order” (i.e. 2 0) denotes zonals (J2 ... JD) only.~~

Table 6-10: OCM Data: Perturbations Specification

Keyword	Description	Units	Default (if any)	Examples of Values	Mandatory M/O/C
PERT_START	Start of the perturbations specification	n/a			Yes <u>M</u>
COMMENT	Comments (a contiguous set of one or more comment lines is allowed in the OCM Perturbations Specification only immediately after the PERT_START key word; see 7.7 for comment formatting rules).	n/a		This is a comment	Ne <u>O</u>
ORBIT_CENTER_NAME ATMOSPHERIC_MODEL	<p>Origin of the perturbations central bodies, which may be a natural solar system body (planets, asteroids, comets, and natural satellites), including any planet barycenter or the solar system barycenter. Select from the accepted set of values indicated in ANNEX B, Section B2.</p> <p>Origin of the perturbing central bodies, which may be a natural solar system body (planets, asteroids, comets, and natural satellites), including any planet barycenter or the solar system barycenter.</p> <p>Natural bodies<u>Name of atmosphere model, which shall be selected from the accepted set of values indicated in ANNEX B, Section B2B9.</u></p> <p>For other reference frame origins, this field is a free text descriptor which can draw upon ground station name, etc.</p>	n/a	EARTH	MSISE90 NRLMSIS00 J70 J71 JROBERTS DTM JB2008 <u>EARTH</u> MOON SOLAR SYSTEM BARYCENTER SUN EROS EARTH_SUN_L2	Ne <u>O</u>
ATMOSPHERIC_MODEL	Name of atmosphere model, which shall be selected from the accepted set of values indicated in ANNEX B, Section B9.	n/a		MSISE90 NRLMSIS00 J70 J71 JROBERTS DTM JB2008	Ne
GRAVITY_MODEL	<p>The gravity model used in the simulation, which shall be selected from the accepted set of values<u>gravity model names</u> indicated in ANNEX B, Section B10-B10, followed by the degree (D) and order (O) of the applied spherical harmonic coefficients used in the simulation.</p> <p><u>NOTE: Specifying a zero value for “order” (e.g., 2D 0O) denotes zonals (J2 ... JD)</u></p>	n/a		EGM-96: 36D 36O WGS-84: 8D 0O GGM-01-: 36D 36O TEG-4: 36D 36O	Ne <u>O</u>

CCSDS PROPOSED STANDARD FOR ORBIT DATA MESSAGES

Keyword	Description	Units	Default (if any)	Examples of Values	Mandatory M/O/C
GRAVITY_MODEL_DEGREE	The GRAVITY_MODEL degree used in the simulation.	n/a		36 12 8	No
GRAVITY_MODEL_ORDER	The GRAVITY_MODEL order used in the simulation.	n/a		36 12 2	No
EQUATORIAL_RADIUS	Oblate spheroid equatorial radius <u>of the central body.</u>	km		6378.137	No <u>O</u>
GM	Gravitational Coefficient <u>coefficient</u> of attracting body (Gravitational Constant x Central Mass) <u>.</u>	km**3 /s**2		3.986004e5	No <u>O</u>
N_BODY_PERTURBATIONS	One OR MORE (N-body) gravitational perturbations bodies used. Values, listed serially in comma-delimited fashion, denote a natural solar or extra-solar system body (stars, planets, asteroids, comets, and natural satellites) <u>.</u> Note that only those entries (or those procedurally added to the CENTER_NAME content as specified in ANNEX B) that are denoted as an "Attracting Body" in ANNEX B, Section B2 are acceptable values.	n/a		MOON, SUN, JUPITER	No <u>O</u>
CENTRAL_BODY_ROTATION	Central body angular rotation rate, measured about the major principal axis of the inertia tensor of the central body, relating inertial and central-body-fixed reference frames. <u>Note that the rotation axis may be slightly offset from the inertial frame Z-axis definition.</u>	deg/s		4.17807421629e-3	No <u>O</u>
OBLATE_FLATTENING	Inverse of the central Central body's oblate spheroid oblateness for the polar-symmetric oblate central body model- <u>(e.g., for the Earth, it is approximately 1.0/298.257223563).</u>	n/a		298.257223563 <u>0.00335281066475</u>	No <u>O</u>
OCEAN_TIDES_MODEL	Name of ocean tides model (optionally specify order or constituent effects, diurnal, semi-diurnal, etc.) <u>.</u>	n/a		DIURNAL SEMI-DIURNAL	No <u>O</u>
SOLID_TIDES_MODEL	Name of solid tides model (optionally specify order or constituent effects, diurnal, semi-diurnal, etc.) <u>.</u>	n/a		DIURNAL SEMI-DIURNAL	No <u>O</u>
REDUCTION_THEORY	Specification of the reduction theory used for precession and nutation modeling. This is a free text field, so if the examples on the right are insufficient, others may be used.	n/a		IAU1976/FK5 IAU2010 IERS1996	No <u>O</u>
ALBEDO_MODEL	Name of the albedo model <u>.</u>	n/a		STK	No <u>O</u>
ALBEDO_GRID_SIZE	# <u>Number</u> of grid points used in the albedo model <u>.</u>	n/a		100	No <u>O</u>
SHADOW_MODEL	Shadow modeling <u>model used</u> for Solar Radiation Pressure; dual cone uses both umbra/penumbra regions. Selected option should be one of "NONE", "CYLINDRICAL", "CONE" <u>"</u> or "DUAL CONE" <u>"</u> .	n/a		NONE CYLINDRICAL DUAL CONE	No <u>O</u>
SHADOW_BODIES	Comma-separated list of planetary bodies for which SRP shadowing is modeled- <u>See, selected from</u> ANNEX B for <u>acceptable ORBIT_CENTER_NAME values (and the procedure to propose new values)</u> <u>.</u>	n/a	Earth <u>EA</u> RTH	EARTH <u>Earth, Moon</u> MOON	No <u>O</u>
SRP_MODEL	Name of SRP model. This is a free text field, so if the examples on the right are insufficient, others may be used.	n/a		GPS_ROCK BOX_WING CANNONBALL COD ...	No <u>O</u>

CCSDS PROPOSED STANDARD FOR ORBIT DATA MESSAGES

	Keyword	Description	Units	Default (if any)	Examples of Values	Mandatory M/O/C
	SW_DATA_SOURCE	Free text field specifying the source and version of the Space Weather data used in the creation of this message. Multiple space weather sources can be specified in a comma-delimited fashion.	n/a		CELESTRAK e.g., "Celestrak space-weather-file downloaded from http://celestrak.com/SpaceData/SW-Last5Years.txt at 2001-11-08T00:00:00"	NeO
	SW_DATA_EPOCH	Epoch when the Space Weather data file was obtained.			2001-11-08T00:00:00"	O
	SW_INTERP_METHOD_SPW% 	Free text field specifying the method used to select or interpolate any and all sequential space weather data (K_p , a_p , Dst, $F_{10.7}$, $M_{10.7}$, $S_{10.7}$, $Y_{10.7}$, etc.).	n/a		PRECEDING_VALUE NEAREST_NEIGHBOR LINEAR LAGRANGE_ORDER_5	NeO
FIXED	GEOMAG_KP	A fixed (time invariant) value of the planetary 3-hour-range geomagnetic index K_p used to override the normal time-varying 3-hourly K_p values (e.g., obtained from SW_SOURCE) for drag perturbations estimation throughout this message's timespan. K_p is the planetary 3-hour range mean standardized index derived from the K-index of 13 geomagnetic observatories between 44 degrees and 60 degrees northern or southern geomagnetic latitude. The scale is 0 to 9 expressed in thirds of a unit, e.g. 5- is 4 2/3, 5 is 5 and 5+ is 5 1/3. This planetary index is designed to measure solar particle radiation by its magnetic effects-DATA_SOURCE).	nT		3.2	NeO
FIXED	GEOMAG_AP	A fixed (time invariant) value of the 3-hourly (equivalent range) geomagnetic index a_p used to override the normal time-varying 3-hourly a_p values (e.g., obtained from SW_SOURCE) for drag perturbations estimation throughout this message's timespan. The 3-hourly (equivalent range) geomagnetic index a_p reports the amplitude of planetary geomagnetic activity for a given day and is translated from the K_p index-DATA_SOURCE).	nT		21	NeO
FIXED	GEOMAG_DST	A fixed (time invariant) value of the planetary 1-hour-range geomagnetic index Dst used to override the normal time-varying daily Dst values (e.g., obtained from SW_SOURCE) for drag perturbations estimation throughout this message's timespan. The Disturbance Storm Time (Dst) index is a proxy for magnetic activity derived from a network of near-equatorial geomagnetic observatories that measures the intensity of the globally symmetrical equatorial electrojet (the storm-time "ring-current" in the inner magnetosphere)-DATA_SOURCE).	nT		-20	NeO

CCSDS PROPOSED STANDARD FOR ORBIT DATA MESSAGES

	Keyword	Description	Units	Default (if any)	Examples of Values	Mandatory M/O/C
FIXED_F10P7		A fixed (time invariant) value of the solar flux daily proxy $F_{10.7}$ used to override the normal time-varying daily $F_{10.7}$ values (e.g., obtained from SW_SOURCE) for drag perturbations estimation throughout this message's timespan. DATA_SOURCE).	Solar Flux Units = 10^4 Jansky = 10^{-22} W/m ² *HzSFU		120.0	NeO
FIXED_F10P7_MEAN		A fixed (time invariant) value of the solar flux 81-day running center-averaged proxy $F_{10.7}$ used to override the normal time-varying averaged $F_{10.7}$ values (e.g., obtained from SW_SOURCE) for drag perturbations estimation throughout this message's timespan. DATA_SOURCE).	Solar Flux Units = 10^4 Jansky = 10^{-22} W/(m ² *Hz) SFU		132.0	NeO
FIXED_M10P7		A fixed (time invariant) value of the solar flux daily proxy $M_{10.7}$ used to override the normal time-varying daily $M_{10.7}$ values (e.g., obtained from SW_SOURCE) for drag perturbations estimation throughout this message's timespan. $M_{10.7}$ is derived from the Mg II core-o-wing ratio that originated from the NOAA series operational satellites, e.g., NOAA 16, NOAA 17, NOAA 18, which host the Solar Backscatter Ultraviolet (SBUV) spectrometer. DATA_SOURCE).	10^{-22} W/(m ² *Hz) SFU		120.0	NeO
FIXED_M10P7_MEAN		A fixed (time invariant) value of the solar flux 81-day running center-averaged proxy $M_{10.7}$ used to override the normal time-varying averaged $M_{10.7}$ values (e.g., obtained from SW_SOURCE) for drag perturbations estimation throughout this message's timespan. DATA_SOURCE).	10^{-22} W/(m ² *Hz) SFU		120.0	NeO
FIXED_S10P7		A fixed (time invariant) value of the solar flux daily proxy $S_{10.7}$ used to override the normal time-varying daily $S_{10.7}$ values (e.g., obtained from SW_SOURCE) for drag perturbations estimation throughout this message's timespan. $S_{10.7}$ is the integrated 26–34 nm solar irradiance measured by the Solar Extreme Ultraviolet Monitor (SEM) instrument on the NASA/ESA Solar and Heliospheric Observatory (SOHO) research satellite. DATA_SOURCE).	10^{-22} W/(m ² *Hz) SFU		120.0	NeO
FIXED_S10P7_MEAN		A fixed (time invariant) value of the solar flux 81-day running center-averaged proxy $S_{10.7}$ used to override the normal time-varying averaged $S_{10.7}$ values (e.g., obtained from SW_SOURCE) for drag perturbations estimation throughout this message's timespan. DATA_SOURCE).	10^{-22} W/(m ² *Hz) SFU		120.0	NeO

CCSDS PROPOSED STANDARD FOR ORBIT DATA MESSAGES

	Keyword	Description	Units	Default (if any)	Examples of Values	Mandatory M/O/C
FIXED_Y10P7		<p>A fixed (time invariant) value of the solar flux daily proxy $Y_{10.7}$ used to override the normal time-varying daily $Y_{10.7}$ values (e.g., obtained from SW_SOURCE) for drag perturbations estimation throughout this message's timespan.</p> <p>$Y_{10.7}$ is a composite index of the X_{b10} and Lyman-α solar indices, weighted to represent mostly X_{b10} during solar maximum and to represent mostly Lyman-α during moderate and low solar activity (DATA_SOURCE).</p>	10^{-22} $W/(m^2 * Hz)$ <u>SFU</u>		120.0	<u>No</u>
FIXED_Y10P7_MEAN		<p>A fixed (time invariant) value of the solar flux 81-day running center-averaged proxy $Y_{10.7}$ used to override the normal time-varying averaged $Y_{10.7}$ values (e.g., obtained from SW_SOURCE) for drag perturbations estimation throughout this message's timespan (DATA_SOURCE).</p>	10^{-22} $W/(m^2 * Hz)$ <u>SFU</u>		120.0	<u>No</u>
PERT_STOP		End of the perturbations specification.	n/a			<u>Yes</u>

6.2.106.2.9 OCM DATA: ORBIT DETERMINATION DATA

~~NOTE: THIS SECTION APPLIES TO ALL ORBIT AND COVARIANCE DATA BASED UPON “DETERMINED” ORBIT SOLUTIONS~~

~~6.2.10.16.2.9.1~~ Table 6-11 provides an overview of the OCM orbit determination data section. Only those keywords shown in Table 6-11 shall be used in OCM orbit determination data specification.

~~6.2.10.26.2.9.2~~ At most, only one Orbit Determination Data section shall appear in an OCM.

~~6.2.10.36.2.9.3~~ Orbit determination data in the OCM shall be indicated by two keywords: OD_START and OD_STOP.

~~6.2.10.4~~ ~~All orbit determination event times~~The values of the DAYS SINCE FIRST OBS, and DAYS SINCE LAST OBS keywords shall be specified as relative to the orbit determination epoch specified via the OD_EPOCH keyword (time, in days, each consisting of 86400 seconds) as a double precision number. Event times may be negative, zero or positive.

~~6.2.10.5~~ A “Sensor Track” is defined above in Section 1.5.

~~6.2.10.66.2.9.4~~ This orbit determination parameters section should reflect the orbit determination settings used to generate all orbit, covariance and state transition matrix sections to the value of the message that are based upon “determined” orbit solutions. OD_EPOCH keyword.

~~6.2.10.76.2.9.5~~ If an orbit determination parameters section is included in the message, a corresponding perturbations section ~~should~~shall be included as well to specify the perturbations incorporated in the orbit determination.

~~6.2.10.86.2.9.6~~ The Orbit Determination ~~specification~~parameters section shall ~~apply~~reflect the orbit determination settings used to generate all OCM orbit ~~and~~, covariance and maneuver time history data sections that are based upon “determined” orbit solutions and contain the ORB BASIS ID, COV BASIS ID and MAN BASIS ID keyword values matching the OD_ID value of the OD block, respectively.

Table 6-11: OCM Data: Orbit Determination Data

Keyword	Description	Units	Default (if any)	Examples of Values	Mandatory M/O/C
OD_START	Start of an orbit determination data section	n/a		n/a	<u>Yes</u> <u>M</u>
COMMENT	Comments (a contiguous set of one or more comment lines is allowed in the OCM Orbit Determination Data section only immediately after the OD_START key word; see 7.7 for comment formatting rules).	n/a		This is a comment	<u>No</u> <u>O</u>
OD_ID	Optional identification number for this orbit determination.	n/a		OD_20160402	<u>No</u> <u>M</u>

CCSDS PROPOSED STANDARD FOR ORBIT DATA MESSAGES

Keyword	Description	Units	Default (if any)	Examples of Values	Mandatory M/O/C
OD_PREV_ID	Optional identification number for the previous orbit determination. Note: if this orbit determination is the first one, then OD_PREV_ID should be excluded from this message.	n/a		OD_20160401	NoQ
OD_METHOD	Type of orbit determination method used to produce the orbit estimate. While this is a free-text field, it is suggested that it be comprised of the method (commonly used methods could, followed by a colon delimiter and the actual OD tool used to estimate the orbit (e.g., BAHN, ODIN, ODTK). <u>NOTE: Commonly-used methods</u> include Batch Weighted Least Squares (BWLS), Extended Kalman Filter (EKF), Sequential Filter (SF), Square Root Information Filter (SRIF), Sequential Simultaneous Estimation Method (SSEM), followed by a colon delimiter and the actual OD tool used to estimate the orbit (e.g., BAHN, ODIN, ODTK).).	n/a		BWLS: BAHN BWLS: ODIN EKFSF : ODTK	YesM
OD_EPOCH	UTC epoch <u>Relative or absolute time tag</u> of the orbit determination solved-for state (See 7.5.10 for formatting rules.) <u>in the selected OCM time system specified by the TIME_SYSTEM keyword.</u>	n/a		2001-11-06T11:17:33 2002-204T15:56:23Z27854.239	YesM
DAYS_SINCE_FIRST_OBS	Days (in SI days, with one day = 86400.0 s) <u>Days</u> elapsed between first accepted observation and OD_EPOCH _x	d		3.5	NoQ
DAYS_SINCE_LAST_OBS	Days (in SI days, with one day = 86400.0 s) <u>Days</u> elapsed between last accepted observation and OD_EPOCH _x	d		1.2	NoQ
RECOMMENDED_OD_SPAN	Number of days (in SI days, with one day = 86400.0 s) <u></u> of observations recommended for the OD of the object (useful only for Batch OD systems).	d		5.2	NoQ
ACTUAL_OD_SPAN	Actual time span in days (in SI days, with one day = 86400.0 s) <u></u> used for the OD of the object (NOTE: should equal (DAYS_SINCE_FIRST_OBS - DAYS_SINCE_LAST_OBS)).	d		2.3	NoQ
OBS_AVAILABLE	The number of observations available within the actual OD time span.	n/a		100	NoQ
OBS_USED	The number of observations accepted within the actual OD time span.	n/a		90	NoQ
TRACKS_AVAILABLE	The number of sensor tracks, <u>available for the OD within</u> the actual time span, that were available for the OD (see definition of "tracks", Section 1.5.3).	n/a		33	NoQ
TRACKS_USED	The number of sensor tracks, <u>accepted for the OD within</u> the actual time span, that were accepted for the OD (see definition of "tracks", Section 1.5.3).	n/a		30	NoQ
MAXIMUM_OBS_GAP	The maximum time between observations in the OD of the object.	d		1.0	NoQ
OD_EPOCH_EIGMAJ	Positional error ellipsoid 1 σ major eigenvalue at the epoch of the OD _x	m		58.73	NoQ
OD_EPOCH_EIGMED	Positional error ellipsoid 1 σ medium <u>intermediate</u> eigenvalue at the epoch of the OD _x	m		35.7	NoQ
OD_EPOCH_EIGMIN	Positional error ellipsoid 1 σ minor eigenvalue at the epoch of the OD _x	m		21.5	NoQ
OD_MAX_PRED_EIGMAJ	The resulting maximum predicted major eigenvalue of the 1 σ positional error ellipsoid over the entire TIME_SPAN of the OCM, stemming from this OD _x	m		21.5	NoQ

CCSDS PROPOSED STANDARD FOR ORBIT DATA MESSAGES

Keyword	Description	Units	Default (if any)	Examples of Values	Mandatory M/O/C
OD_MIN_SIGMA_PRED_EIGMIN	The resulting minimum predicted major minor eigenvalue of the 1σ positional error ellipsoid over the entire TIME_SPAN of the OCM, stemming from this OD.	m		21.5	No
OD_CONFIDENCE	OD confidence metric, which by definition spans 0 to 100%. (useful only for Filter-based OD systems). The OD confidence metric shall be as mutually defined by message exchange participants.	Percent		95.3	No
GDOP	Generalized Dilution Of Precision for this orbit determination, based on the observability gramman as defined in Kaplan “Understanding GPS: Principles ANEX N, References [N-13] and Applications” [N-14] and expressed in Informative Annex C4C4 . GDOP provides a rating metric of the observability of the element set from the OD. Alternate GDOP formations may be used as mutually defined by message exchange participants.	n/a		.857	No
SOLVE_N	The number of solve-for states in the orbit determination.	n/a		6	No
SOLVE_STATES	Free-text comma-delimited description of the state elements solved for in the orbit determination.	n/a		POS{[3]}; VEL{[3]}	No
CONSIDER_N	The number of consider parameters used in the orbit determination.	n/a		3	No
CONSIDER_PARAMS	Free-text comma-delimited description of the consider parameters used in the orbit determination.	n/a		DRAG, SRP	No
SENSORS_N	The number of sensors used in the orbit determination.	n/a		3	No
SENSORS	Free-text comma-delimited description of the sensors used in the orbit determination.	n/a		EGLIN, FYLINGDALES	No
INTEG_STEP_SIZE	Integration step size. A value of zero ‘0’ shall be used to denote a variable integration step size, if this optional parameter is specified.	s		60.0	No
WEIGHTED_RMS	<p><i>(Useful / valid only for Batch OD systems).</i></p> <p>The weighted RMS residual ratio, defined as:</p> $\text{Weighted RMS} = \sqrt{\frac{\sum_{i=1}^N w_i (y_i - \hat{y}_i)^2}{N}}$ <p>Where y_i is the observation measurement at the ith time</p> <p>\hat{y}_i is the current estimate of y_i,</p> <p>$w_i = \frac{1}{\sigma_i^2}$ is the weight (sigma) associated with the measurement at the ith time and N is the number of observations.</p> <p>This is a value that can generally identify the quality of the most recent vector update, and is used by the analyst in evaluating the OD process. A value of 1.00 is ideal.</p>	(measurement units)		1.3	No

CCSDS PROPOSED STANDARD FOR ORBIT DATA MESSAGES

Keyword	Description	Units	Default (if any)	Examples of Values	Mandatory M/O/C
TDM_ FB MSG_LINK	An alphanumeric free-text string containing a comma-separated list of file name(s) and/or associated identification number(s) of Tracking Data Message (TDM) [9][9] observations upon which this OD is based.	n/a		TDM_0005MSG_353 2.txt TDM_835, TDM_836	NoO
DATA_TYPES	Comma-separated list of observation data types utilized in this orbit determination. Although this is a free-text field, it is recommended at a minimum to use data type descriptor(s) as provided in Table 3-5 of the TDM standard [9][9] (excluding the DATA_START, DATA_STOP, and COMMENT keywords). Additional descriptors/detail is encouraged if the descriptors of Table 3-5 are not sufficiently clear, e.g., could replace ANGLE_1 and ANGLE_2 with RADEC (e.g., from a telescope), AZEL (e.g., from a ground radar), RANGE (whether from radar or laser ranging), etc.	n/a		n/a ANGLE_1, ANGLE_2	NoO
OD_STOP	End of an orbit determination data section.	n/a		n/a	YesM

6.2.11.6.2.10 OCM DATA: USER-DEFINED PARAMETERS

6.2.11.16.2.10.1 A single section of User Defined Parameters ~~may be provided if necessary is allowed~~. In principle, this provides flexibility, but also introduces complexity, non-standardization, potential ambiguity, and potential processing errors. Accordingly, if used, the keywords and their meanings must be described in an ICD; ~~comments are also encouraged to further describe the user parameters.~~ User Defined Parameters, if included ~~in an OCM~~, should be used as sparingly as possible; their use is not encouraged.

6.2.11.26.2.10.2 At most, only one User-Defined Parameters section shall appear in an OCM.

6.2.11.36.2.10.3 Table 6-12 provides an overview of the OCM user-defined data section. Only those keywords shown in Table 6-12 shall be used in OCM user-defined data specification.

Table 6-12: OCM Data: User-Defined Parameters

Keyword	Description	Units	Examples of Values	Mandatory M/O/C
USER_START	Start of a User- defined parameters <u>Defined Parameters</u> data block.	n/a		Yes <u>M</u>
COMMENT	Comments (a contiguous set of one or more comment lines is allowed immediately following the USER_START keyword (See 7.7 for formatting rules-)). <u>)).</u>	n/a	This is a comment	No <u>O</u>
USER_ <u>DEFINED</u> _X	User-defined keyword(s) paired with user-specified parameter, where 'x' is replaced by a variable length user specified character string values. Multiple. Any number of user-defined parameters may be specified in this manner, but only as included, if necessary to provide essential information that cannot be otherwise conveyed in standard OCM content and accompanying comments. <u>COMMENT</u> statements. Example: <u>USER_DEFINED_EARTH_MODEL = WGS-84</u>	n/a	<u>USER_DEFINED_EARTH_MODEL = WGS-84</u>	No <u>O</u>
USER_STOP	End of a User- defined parameters <u>Defined Parameters</u> data block.	n/a		Yes <u>M</u>

6.3 OCM EXAMPLES AND SUPPLEMENTARY INFORMATION

Example OCMs and associated supplementary (non-normative) information are provided in Annex G.

7 ORBIT DATA MESSAGE SYNTAX

7.1 OVERVIEW

This section details the syntax requirements for each of the Orbit Data Messages.

7.2 GENERAL

The Orbit Data Messages (OPM, OMM, OEM, and OCM) shall observe the syntax described in 7.3 through 7.8.

7.3 ODM LINES

7.3.1 Each OPM, OMM, OEM, or OCM line shall be one of the following:

- Header line;
- Metadata line;
- Data line;
- Comment line; or
- Blank line.

7.3.2 Each OPM, OMM, or OEM line must not exceed 254 ASCII characters and spaces (excluding line termination character[s]).

7.3.3 OCM lines may be of arbitrary length. If exchange between the two parties requires a maximum line length, that limit should be ~~negotiated and specified in an ICD~~ mutually agreed between message exchange partners.

7.3.4 Only printable ASCII characters and blanks shall be used. Control characters (such as TAB, etc.) shall not be used, with the exception of the line termination characters specified below.

7.3.5 Blank lines may be used at any position within the file. Blank lines shall have no assignable meaning, and may be ignored.

7.3.6 The first header line must be the first non-blank line in the file.

7.3.7 All lines shall be terminated by a single Carriage Return or a single Line Feed, ~~or a~~ Carriage Return/Line Feed pair, or a Line Feed/Carriage Return pair.

7.4 ORBIT DATA MESSAGES IN “KEYWORD = VALUE NOTATION” (I.E., NON-XML) AND ORDER OF ASSIGNMENT STATEMENTS

7.4.1 For the OPM and OMM, all header, metadata, and data lines shall use ‘keyword = value’ notation, abbreviated as KVN.

7.4.1.1 For the OEM, all header and metadata elements shall use KVN notation.

7.4.1.2 OEM ephemeris data lines shall not use KVN format; rather, the OEM ephemeris data line has a fixed structure containing seven required fields (epoch time, three position components, three velocity components), and three optional acceleration components. (See 5.2.4.)

7.4.1.3 OEM covariance matrix epoch and covariance reference frame (if used) shall use KVN format. The OEM covariance data lines shall not use KVN format; rather, the OEM covariance data line has a fixed structure containing from one to six required fields (a row from the 6x6 lower triangular form covariance matrix). (See 5.2.5.)

7.4.1.4 For the OCM, all header and metadata elements shall use KVN notation.

7.4.1.5 OCM orbit state time history data lines shall not use KVN format; rather, the structure of such OCM orbit state time history data ~~lines~~ shall be comprised of a contiguous set of lines containing time tag followed by the parameters corresponding to the selected orbit set (~~See~~ [6.2.4](#)).

7.4.1.6 OCM covariance matrix epoch and covariance reference frame (if used) shall use KVN format. The OCM covariance data lines shall not use KVN format; rather, ~~the~~ OCM covariance [time history](#) data ~~line has a fixed structure which~~ shall be comprised of a contiguous set of lines containing ~~from one to “N” required fields (a row from time tag followed by the Lower Triangular Matrix (LTM) content (e.g., [1,1], [2,1], [2,2], [3,1], ...) of the N x N lower triangular form of a square covariance matrix); corresponding to the selected covariance type.~~ Alternately, the covariance may be represented by a ~~single line~~ [contiguous set of lines](#) containing epoch followed by the major eigenvalue, ~~medium~~ [intermediate](#) eigenvalue, minor eigenvalue, and their corresponding major, ~~medium~~ [intermediate](#), and minor eigenvectors. (~~See (see 6.2.6.)~~).

~~**7.4.1.7** OCM state transition matrix data lines shall not use KVN format; rather, OCM state transition matrix data shall be comprised of a contiguous set of lines containing a fixed structure as presented in Sec. 6.2.7.~~

~~**7.4.1.8**~~ **7.4.1.7** OCM maneuver data lines shall not use KVN format; rather, OCM maneuver data shall be comprised of a contiguous set of lines containing a fixed structure as presented in Sec. ~~6.2.8~~ [7](#).

7.4.2 The keywords ‘COMMENT’, ~~[wild-card]~~ [*‘](#) START’ and ~~[wild-card]~~ [*‘](#) STOP’ are exceptions to the KVN syntax assignment.

7.4.3 Only a single ‘keyword = value’ assignment shall be made on a line.

7.4.4 Keywords must be uppercase and must not contain blanks.

7.4.5 Any white space immediately preceding or following the keyword shall not be significant.

7.4.6 Any white space immediately preceding or following the ‘equals’ sign shall not be significant.

7.4.7 Any white space immediately preceding the end of line shall not be significant.

7.4.8 The order of occurrence of mandatory and optional KVN assignments shall be fixed as shown in the tables in sections 3, 4, 5, and 6 that describe the OPM, OMM, OEM, and OCM keywords.

7.5 VALUES

7.5.1 A non-empty value field must be ~~specified for assigned to~~ each mandatory keyword except ~~as noted in §7.4.2 above for~~ *‘ START’ and *‘ STOP’ keyword values.

7.5.2 Comments and free-text value fields may be in any case (or mix of case) desired by the user.

7.5.3 Apart from comments and free-text fields, normative text value fields must be constructed using only **exclusively all uppercase** or **exclusively all lowercase**.

7.5.4 Integer values shall consist of a sequence of decimal digits with an optional leading sign (‘+’ or ‘-’). If the sign is omitted, ‘+’ shall be assumed. Leading zeroes may be used. The range of values that may be expressed as an integer is:

$$-2,147,483,648 \leq x \leq +2,147,483,647 \quad (\text{i.e., } -2^{31} \leq x \leq 2^{31}-1).$$

NOTE – The commas in the range of values above are thousands separators and are used only for readability. They should not appear in an actual message.

7.5.5 Non-integer numeric values may be expressed in either fixed-point or floating-point notation. Both representations may be used within an OPM, OMM, OEM, or OCM.

7.5.6 Non-integer numeric values expressed in fixed-point notation shall consist of a sequence of decimal digits separated by a period as a decimal point indicator, with an optional leading sign (‘+’ or ‘-’). If the sign is omitted, ‘+’ shall be assumed. Leading and trailing zeroes may be used. At least one digit shall appear before and after a decimal point.

7.5.7 Non-integer numeric values expressed in floating point notation shall consist of a sign, a mantissa, an alphabetic character indicating the division between the mantissa and exponent, and an exponent, constructed according to the following rules:

- a) The sign may be '+' or '-'. If the sign is omitted, '+' shall be assumed.
- b) The mantissa must be a string of no more than 16 decimal digits with a decimal point ('.') in the second position of the ASCII string, separating the integer portion of the mantissa from the fractional part of the mantissa.
- c) The character used to denote exponentiation shall be 'E' or 'e'. If the character indicating the exponent and the following exponent are omitted, an exponent value of zero shall be assumed (essentially yielding a fixed-point value).
- d) The exponent must be an integer, and may have either a '+' or '-' sign (if the sign is omitted, then '+' shall be assumed).
- e) The maximum positive floating-point value is approximately 1.798E+308, with 16 significant decimal digits precision. The minimum positive floating-point value is approximately 4.94E-324, with 16 significant decimal digits precision.

7.5.8 Blanks shall not be permitted within numeric values and time strings.

7.5.9 In value fields that are text, an underscore shall be equivalent to a single blank. Individual blanks shall be retained (shall be significant), but multiple contiguous blanks shall be equivalent to a single blank.

7.5.10 In value fields that represent an absolute time tag or epoch, times shall be given in one of the following two formats:

YYYY-MM-DDThh:mm:ss[.d→d][Z]

or

YYYY-DDDThh:mm:ss[.d→d][Z]

where 'YYYY' is the year, 'MM' is the two-digit month, 'DD' is the two-digit day, 'DDD' is the three-digit day of year, 'T' is constant, 'hh:mm:ss[.d→d]' is the time in hours, minutes, seconds, and optional fractional seconds; 'Z' is an optional time code terminator (the only permitted value is 'Z' for Zulu, i.e., UTC). As many 'd' characters to the right of the period as required may be used to obtain the required precision, up to the maximum allowed for a fixed-point number. All fields shall have leading zeros. (See reference [1], 2, ASCII Time Code A or B.). ~~Where such epochs occur within one second after leap second introduction, the hh:mm:ss portion of the above time specification shall use the convention XX:XX:60.XXXX.~~

NOTE: During a leap second introduction, the value of the two-digit integer seconds (ss) field shall be '60' as specified on page 3-6 of reference [2].

7.5.11 The time system for CREATION_DATE is UTC; for all other keywords representing times or epochs, the time system is determined by the TIME_SYSTEM metadata keyword.

7.6 UNITS IN THE ORBIT DATA MESSAGES

7.6.1 OPM/OMM UNITS

7.6.1.1 For documentation purposes and clarity only, units may be included as ASCII text after a value in the OPM and OMM. If units are displayed, they must exactly match the units (including lower/upper case) as specified in tables 3-3, 4-3, ~~6-3 and 6-4 through 6-12.~~ If units are displayed, then:

- a) there must be at least one blank character between the value and the units text;
- b) the units must be enclosed within square brackets (e.g., '[km]');
- c) multiplication shall be denoted by a single asterisk (e.g., '[N*m]');
- d) division shall be denoted by a single forward slash (e.g., meters per second is km/s);
- e) exponents of units shall be denoted with a double asterisk (i.e., '**', for example, $\text{km}^2=\text{km}^{**2}$);
- f) The usual order of operations ordering applies (e.g., exponents before multiplication).

7.6.1.2 Some of the items in the applicable tables are dimensionless. The table shows a unit value of 'n/a', which in this case means that there is no applicable units designator for these items (e.g., for ECCENTRICITY). ~~The notation '[n/a]' should not appear in an OPM, OCM or OMM.~~

7.6.1.3 The notation '[n/a]' shall not appear in an OPM or OMM.

7.6.2 OEM UNITS

7.6.2.1 In an OEM ephemeris data line, units shall be km, km/s, and km/s^{**2} for position, velocity, and acceleration components, respectively, but the units shall not be displayed.

7.6.2.2 In an OEM covariance matrix line, units shall be km^{**2} , km^{**2}/s , or $\text{km}^{**2}/\text{s}^{**2}$ depending on whether the element is computed from two position components, one position component and one velocity component, or two velocity components. The units shall not be displayed.

7.6.3 OCM UNITS

7.6.4 Units for OCM metadata keywords and OCM data block metadata sub-section keywords shall match the units specified in Table 6-3 through Table 6-12.

7.6.5 The units of orbit time state history data lines, where present, shall be specified using the ORB_UNITS keyword. Suggested units for orbit states are provided in the SANA Registry [11] for Orbital Elements (Annex B7).

7.6.6 The units of covariance time history data lines, where present, shall be specified using the COV UNITS keyword. Suggested units for covariance data are provided in the SANA Registry [11] for Orbital Elements (Annex B7) and Additional Covariance Representations (Annex B8).

7.6.7 The units of maneuver time history data lines, where present, shall be specified using the MAN UNITS keyword. Suggested units for maneuver lines are provided in Table 6-8 and Table 6-9.

7.6.4.7.6.8 Apart from orbit state, covariance and maneuver data lines, units of OCM keyword values shall be compatible with the ~~corresponding orbit, covariance, or state transition matrix type's requisite combination of units specified in the SANA registry [11–18]), or if not provided there for a specific keyword, then the~~ “Units” column of the accompanying Keyword Value Tables (i.e., Tables 6-4 through 6-12) for each ~~section~~section definition.

NOTE: ~~While the~~The units used throughout the OCM are generally a combination of kilometers for distance and seconds for time (e.g., km/s for velocity, km/s² for acceleration, and so forth). Mass is in kilograms, and force is in Netwons).

7.6.8.1 ~~In~~Units shall not be displayed in OCM orbit state, covariance, or ~~state transition matrix~~maneuver data linelines.

7.6.4.17.6.8.2 For OCM keywords that are not used to convey orbit state, covariance, or maneuver data lines, ~~units shall not be displayed.~~may be included as ASCII text after a value in the OCM for documentation purposes and clarity only. If units are displayed, they must exactly match the units (including lower/upper case) as specified in tables 6-3 through 6-12. If units are displayed, then:

- g) there must be at least one blank character between the value and the units text;
- h) the units must be enclosed within square brackets (e.g., '[km]');
- i) multiplication shall be denoted by a single asterisk (e.g., '[N*m]');
- j) division shall be denoted by a single forward slash (e.g., meters per second is km/s);
- k) exponents of units shall be denoted with a double asterisk (i.e., '**', for example, km²=km**2);
- l) The usual order of operations ordering applies (e.g., exponents before multiplication).

7.6.8.3 Some of the items in the applicable tables are dimensionless. The table shows a unit value of 'n/a', which in this case means that there is no applicable units designator for these items (e.g., for ECCENTRICITY) and no units displayed.

7.6.8.4 Apart from the ORB UNITS, COV UNITS and MAN UNITS specifiers for orbit, covariance and maneuver data lines, respectively, the notation '[n/a]' shall not appear in an OCM (i.e., units shall be omitted when dimensionless).

7.7 COMMENTS IN THE ORBIT DATA MESSAGES

7.7.1 There are certain pieces of information that provide clarity and remove ambiguity about the interpretation of the information in a file, yet are not standardized so as to fit cleanly into the ‘keyword = value’ paradigm. Rather than force the information to fit into a space limited to one line, the ODM producer should put ~~ertain further specifications and~~ information into comments ~~and use~~. Static information should be separately shared and/or mutually agreed between message exchange partners outside of the ICD to provide further specifications~~ODM~~.

7.7.2 Comments may be used to provide provenance information or to help describe dynamical events or other pertinent information associated with the data. This additional information is intended to aid in consistency checks and elaboration where needed, but shall not be required for successful processing of a file.

7.7.3 For the OPM, OMM, OEM₂, and OCM, comment lines shall be optional.

7.7.4 Comment text may be in any case (or mix of case) desired by the user.

7.7.5 All comment lines shall begin with the ‘COMMENT’ keyword followed by at least one space. This keyword must appear on every comment line, not just the first such line. The remainder of the line shall be the comment value. White space shall be retained (shall be significant) in comment values.

7.7.6 Placement of comments shall be as specified in the tables in sections 3, 4, 5, and 6 that describe the OPM, OMM, OEM₂, and OCM keywords.

7.7.7 Comments in the OPM may appear in the OPM Header immediately after the ‘CCSDS_OPM_VERS’ keyword, at the very beginning of the OPM Metadata section, and at the beginning of a logical block in the OPM Data section. Comments must not appear between the components of any logical block in the OPM Data section.

NOTE – The logical blocks in the OPM Data section are indicated in table 3-3.

7.7.8 Comments in the OMM may appear in the OMM Header immediately after the ‘CCSDS_OMM_VERS’ keyword, at the very beginning of the OMM Metadata section, and at the beginning of a logical block in the OMM Data section. Comments must not appear between the components of any logical block in the OMM Data section.

NOTE – The logical blocks in the OMM Data section are indicated in table 4-3.

7.7.9 Comments in the OEM may appear in the OEM Header immediately after the ‘CCSDS_OEM_VERS’ keyword, at the very beginning of the OEM Metadata section (after the ‘META_START’ keyword), at the beginning of the OEM Ephemeris Data Section, and at the beginning of the OEM Covariance Data section (after the ‘COV_START’ keyword). Comment lines must not appear within any block of ephemeris lines or covariance matrix lines.

7.7.10 ~~Comments in the OCM may appear in the OCM Header, Metadata, Space Object Physical Characteristics, Force Model, Maneuver, Orbit State Time History, Covariance Time History, State Transition Matrix Time History, and User Defined Parameters data sections~~ Comments may appear in all logical blocks of the OCM, but only at the positions shown in the defining Tables (generally at the top of each section, following the *_START section delimiting keyword).

7.7.11 Extensive comments in an ODM are recommended in cases where ~~there is insufficient time to negotiate an ICD~~ that content is germane to the message and changes from message to message.

7.7.12 The following comments should be provided:

- a) Information regarding the genesis, history, interpretation, intended use, etc., of the state vector, spacecraft, maneuver, or ephemeris that may be of use to the receiver of the OPM, OMM, or OEM:

COMMENT Source: File created by JPL Multi-Mission Navigation Team as part
COMMENT of Launch Operations Readiness Test held on 20 April 2001.

- b) Natural body ephemeris information: When the Earth is not the center of motion, the ephemerides of the planets, satellites, asteroids, and/or comets (including associated constants) consistent with the ODM should be identified so that the recipient can, in a consistent manner, make computations involving other centers:

COMMENT Based on latest orbit solution which includes observations
COMMENT through 2000-May-15 relative to planetary ephemeris DE-0405.

- c) OEM accuracy vs. efficiency: If the covariance data section of the OEM is not utilized, the producer of an OEM should report in comment lines what the expected accuracy of the ephemeris is, so the user can smooth or otherwise compress the data without affecting the accuracy of the trajectory. The OEM producer also should strive to achieve not only the best accuracy possible, ~~taking into account~~ considering prediction errors, but also consider the efficiency of the trajectory representation (e.g., step sizes of fractional seconds between ephemeris lines may be necessary for precision scientific reconstruction of an orbit, but are excessive from the standpoint of antenna pointing predicts generation).

7.8 ORBIT DATA MESSAGE KEYWORDS

7.8.1 VERSION KEYWORDS

The Header of the OPM, OMM, OEM₂ and OCM shall provide a CCSDS Orbit Data Message version number that identifies the format version; this is included to anticipate future changes. The version keywords for the OPM, OMM, OEM₂ and OCM shall be CCSDS_OPM_VERS,

CCSDS_OMM_VERS, CCSDS_OEM_VERS, and CCSDS_OCM_VERS, respectively. The value shall have the form of 'x.y', where 'y' shall be incremented for corrections and minor changes, and 'x' shall be incremented for major changes. Version x.0 shall be reserved for versions accepted by the CCSDS as an official Recommended Standard ('Blue Book'). Testing shall be conducted using OPM, OMM, OEM, and OCM version numbers less than 1.0 (e.g., 0.x). ~~Exchange participants should specify in the ICD the~~The specific OPM, OMM, OEM, and OCM version numbers ~~they will support~~to be used should be mutually agreed between message exchange partners. The following version numbers are supported (Blue Book) or have been supported in the past (Silver Book):

Version Keyword	Version Number	Applicable Recommendation
CCSDS_OPM_VERS	1.0	Silver Book 1.0, 09/2004
CCSDS_OPM_VERS	2.0	Silver Book 2.0, 09/2009
CCSDS_OPM_VERS	3.0	Blue Book 3.0 (this document)
CCSDS_OMM_VERS	2.0	Silver Book 2.0, 09/2009
CCSDS_OMM_VERS	3.0	Blue Book 3.0 (this document)
CCSDS_OEM_VERS	1.0	Silver Book 1.0, 09/2004
CCSDS_OEM_VERS	2.0	Silver Book 2.0, 09/2009
CCSDS_OEM_VERS	3.0	Blue Book 3.0 (this document)
CCSDS_OCM_VERS	3.0	Blue Book 3.0 (this document)

7.8.2 GENERAL KEYWORDS

7.8.2.1 Only those keywords shown in table 3-1, table 3-2, and table 3-3 shall be used in an OPM. Some keywords represent mandatory items and some are optional. KVN assignments representing optional items may be omitted.

7.8.2.2 Only those keywords shown in table 4-1, table 4-2, and table 4-3 shall be used in an OMM. Some keywords represent mandatory items and some are optional. KVN assignments representing optional items may be omitted.

7.8.2.3 Only those keywords shown in table 5-2 and table 5-3 shall be used in an OEM. Some keywords represent mandatory items and some are optional. KVN assignments representing optional items may be omitted.

~~**7.8.2.4** Only those keywords shown in tables 6-2, [table 6-3](#), [table 6-4](#), [table 6-5](#), [table 6-6](#), [table 6-7](#), [table 6-9](#), [table 6-10](#), [table 6-11](#), [table 6-12](#), and [table 6-13](#) shall be used in an OCM. Some keywords represent mandatory items and some are optional. KVN assignments representing optional items may be omitted.~~

8 CONSTRUCTING AN ODM/XML INSTANCE

8.1 OVERVIEW

This section provides detailed instructions for the user on how to create an XML message based on one of the ~~ASCII-text~~ KVN-formatted messages described in Section 3, Section 4, Section 5, and Section 6. The section applies only to the XML representation of the ODM messages.

The ODM/XML schemas are available on the SANA Web site. SANA is the registrar for the protocol registries created under CCSDS. The ODM/XML schemas explicitly define the permitted data elements and values acceptable for the XML versions of the ODM messages. The location of the ODM/XML schemas is:

OPM: <https://sanaregistry.org/r/ndmxml/ndmxml-1.0-opm-3.0.xsd>

OMM: <https://sanaregistry.org/r/ndmxml/ndmxml-1.0-omm-3.0.xsd>

OEM: <https://sanaregistry.org/r/ndmxml/ndmxml-1.0-oem-3.0.xsd>

OCM: <https://sanaregistry.org/r/ndmxml/ndmxml-1.0-ocm-3.0.xsd>

Figure 8-1/~~Figure 8-1~~Figure 8-1 illustrates the basic structure of an ODM/XML instance. Defined structural elements are the header and body. The body then consists of one or more segments depending on the message type (one for the OPM, OMM, and OCM; one or more for the OEM). Each segment consists of a <metadata>/<data> pair. In an OEM, which could have more than one segment, the metadata/data pair is repeated in each segment.

```

<header>
</header>
<body>
  <segment>
    <metadata>
    </metadata>
    <data>
    </data>
  </segment>
</body>

```

Figure 8-1: ODM/XML Basic Structure

ODM/XML tags for keywords defined in in Section 3, Section 4, Section 5, and Section 6 appear just as in the KVN, i.e., all capital letters. Tags related to the XML message structure (i.e., that do not correspond directly to a KVN keyword) appear in 'lowerCamelCase' (e.g., <header>, <segment>, <metadata>, <stateVector>, <covarianceMatrix>, etc.).

8.2 XML VERSION

The first line of each instantiation shall specify the XML version, ~~exactly as follows:~~

```
<?xml version="1.0" encoding="UTF-8"?>
```

This line must appear on the first line of each instantiation, exactly as shown.

8.3 BEGINNING THE INSTANTIATION: ROOT ELEMENT TAG

8.3.1 Each instantiation shall have a ‘root element tag’ that identifies the message type and other information such as where to find the applicable schema, required attributes, etc.

8.3.2 The root element tag in an ODM/XML instantiation shall be one of those listed in Table 8-1.

Table 8-1: ODM/XML Root Element Tags

Root Element Tag	Message Type
<opm></opm>	Orbit Parameter Message
<omm></omm>	Orbit Mean Elements Message
<oem></oem>	Orbit Ephemeris Message
<ocm></ocm>	Orbit Comprehensive Message

8.3.3 The XML Schema Instance namespace attribute must appear in the root element tag of all ODM/XML instantiations, exactly as shown:

```
xmlns:xsi="http://www.w3.org/2001/XMLSchema-instance"
```

If it is desired to validate an instantiation against the CCSDS Web-based schema, the `xsi:noNamespaceSchemaLocation` attribute must be coded as a single string of non-blank characters, with no line breaks exactly as shown:

```
xsi:noNamespaceSchemaLocation="http://sanaregistry.org/r/ndmxml/ndmxml-1.0-master.xsd"
```

NOTE – The value associated with the `xsi:noNamespaceSchemaLocation` attribute shown in this document is too long to appear on a single line.

8.3.4 For use in a local operations environment, the schema set may be downloaded from the ~~CCSDS Web site~~ [SANA website](#) to a local server that meets local requirements for operations robustness.

8.3.5 If a local version is used, the value associated with the `xsi:noNamespaceSchemaLocation` attribute must be changed to a URL that is accessible to the local server.

8.3.6 Two attributes shall appear in the root element tag of an ODM/XML single message instantiation, specifically, the `CCSDS_xxx_VERS` keyword that is also part of the standard KVN header, and the Blue Book version number. The final attributes of the root element tag shall be 'id' and 'version'.

8.3.7 The `CCSDS_xxx_VERS` keyword shall be supplied via the 'id' attribute of the root element tag. The id' attribute shall be 'id="CCSDS_xxx_VERS"', where xxx = OPM, OMM, OEM, or OCM).

8.3.8 The version number of the Blue Book to which the schema applies shall be supplied via the 'version' attribute. The 'version' attribute shall be 'version="3.0" '.

NOTE – The following example root element tag for an OPM instantiation combines all the directions in the preceding several Sections:

```
<?xml version="1.0" encoding="UTF-8"?>
<opm xmlns:xsi="http://www.w3.org/2001/XMLSchema-instance"
xsi:noNamespaceSchemaLocation="http://sanaregistry.org/r/nd
mxml/ndmxml-1.0-master.xsd"
id="CCSDS_OPM_VERS" version="3.0">
```

8.4 THE STANDARD ODM/XML HEADER SECTION

8.4.1 The ODMs shall share a standard header section, with tags `<header>` and `</header>`.

8.4.2 Immediately following the `<header>` tag the message may have any number of `<COMMENT>` elements.

8.4.3 The standard ODM header shall contain the `<CREATION_DATE>` and the `<ORIGINATOR>` elements.

8.4.4 The standard ODM header may contain the `<MESSAGE_ID>` element.

NOTE – An example `<header>` section is shown immediately below.

```
<header>
  <COMMENT>This is the common ODM/XML header</COMMENT>
  <COMMENT>I can put as many comments here as I want</COMMENT>
  <COMMENT>including none</COMMENT>
  <CREATION_DATE>2004-281T17:26:06</CREATION_DATE>
  <ORIGINATOR>AGENCY-X</ORIGINATOR>
  <MESSAGE_ID>XYZ123-2019</MESSAGE_ID>
```

</header>

8.5 THE ODM/XML BODY SECTION

8.5.1 After coding the <header>, the instantiation must include a <body> section.

8.5.2 Inside the <body> section must appear at least one <segment> section.

8.5.3 Each segment must be made up of one or more <metadata> and <data> sections, depending on the specific message type.

8.6 THE ODM/XML METADATA SECTION

8.6.1 All ODMs must have a metadata section.

8.6.2 The metadata section shall be delimited by the <metadata> element.

8.6.3 Between the <metadata> and </metadata> tags, the keywords shall be the same as those in the metadata sections in Section 3, Section 4, Section 5, and Section 6, with possible exceptions as noted in the Sections below that discuss creating instantiations of the specific messages.

8.7 THE ODM/XML DATA SECTION

8.7.1 All ODMs must have a data section.

8.7.2 The data section shall follow the metadata section and shall be delimited ~~the~~ by the <data> element.

8.7.3 Between the <data> and </data> tags, the keywords shall be the same as those in the data sections in Section 3, Section 4, Section 5, and Section 6, with possible exceptions as noted in the Sections that discuss creating instantiations of the specific messages.

8.8 CREATING AN OPM INSTANTIATION

8.8.1 An OPM instantiation shall be delimited with the <opm></opm> root element tags using the standard attributes documented in **8.3**.

8.8.2 The final attributes of the <opm> tag shall be 'id' and 'version'.

8.8.3 The 'id' attribute shall be 'id="CCSDS_OPM_VERS"'.

8.8.4 The 'version' attribute shall be 'version="3.0"'.

8.8.5 The standard NDM header shall follow the <opm> tag (see **8.4**).

8.8.6 The OPM <body> shall consist of a single <segment>.

8.8.7 The <segment> shall consist of a <metadata> section and a <data> section.

8.8.8 The keywords in the <metadata> and <data> sections shall be those specified in Section 3. The rules for including any of the keyword tags in the OPM/XML are the same as those specified for the OPM/KVN.

8.8.9 Tags for keywords specified in Section 3 shall be all uppercase.

8.8.10 Several of the OPM/XML keywords may have the unitunits attribute.

8.8.11 In all cases, the units shall match those defined in the tables in Section 3.

8.8.12 The following table lists examples of the use of units in the OPM/XML. ~~[NOTE TO DAN: Previously this was an exhaustive list, but the number of elements in the OCM suggested to me that provision of examples would be sufficient to illustrate the method.]~~

Keyword	Units	Example
X	km	<X units="km">numeric-value</X>
X_DOT	km/s	<X_DOT units="km/s">numeric-value</X_DOT>
INCLINATION	deg	<INCLINATION units="deg">numeric-value</INCLINATION>
GM	km**3/s**2	<GM units="km**3/s**2">numeric-value</GM>
MASS	kg	<MASS units="kg">numeric-value</MASS>
SOLAR_RAD_AREAX	m**2km	<SOLAR_RAD_AREAX units="m**2km">numeric-value</SOLAR_RAD_AREAX>
CX_X	km**2	<CX_X units="km**2">numeric-value</CX_X>
CX_DOT_X	km**2/s	<CX_DOT_X units="km**2/s">numeric-value</CX_DOT_X>
CX_DOT_X_DOT,	km**2/s**2	<CX_DOT_X_DOT units="km**2/s**2">numeric-value</CX_DOT_X_DOT>
MAN_DURATIONGM	km**3/s**2	<MAN_DURATIONGM units="km**3/s**2">numeric-value</MAN_DURATIONGM>
X_DOT	km/s	<X_DOT units="km/s">numeric-value</X_DOT>
MAN_DV_1	km/s	<MAN_DV_1 units="km/s">numeric-value</MAN_DV_1>
SOLAR_RAD_AREA	m**2	<SOLAR_RAD_AREA units="m**2">numeric-value</SOLAR_RAD_AREA>
MAN_DURATION	s	<MAN_DURATION units="s">numeric-value</MAN_DURATION>

8.8.13 In addition to the OPM keywords specified in Section 3, there are several special tags associated with the OPM body as described in the next few Sections. The information content in the OPM is separated into “logical blocks”-blocks. Special tags in the OPM are used to encapsulate the information in the logical blocks of the OPM.

8.8.14 The OPM/XML tags used to delimit the logical blocks of the OPM shall be drawn from the following table:

OPM Logical Block	Associated ODM/XML OPM Tag
State Vector	<stateVector>
Keplerian Elements	<keplerianElements>
Spacecraft Parameters	<spacecraftParameters>
Covariance Matrix	<covarianceMatrix>
Maneuver Parameters	<maneuverParameters> <u><maneuvers></u>
User Defined Parameters	<userDefinedParameters>—(see 8.???)

8.8.15 Between the begin tag and end tag (i.e., between <spacecraftParameters> and </spacecraftParameters>), the user shall place the keywords required by the specific logical block as specified in Section 3.

8.9 CREATING AN OMM INSTANTIATION

8.9.1 An OMM instantiation shall be delimited with the `<omm></omm>` root element tags using the standard attributes documented in **8.3**.

8.9.2 The final attributes of the `<omm>` tag shall be 'id' and 'version'.

8.9.3 The 'id' attribute shall be 'id="CCSDS_OMM_VERS"'.

8.9.4 The 'version' attribute for the version of the OMM described in Section 4 shall be 'version="3.0"'.

8.9.5 The standard NDM header shall follow the `<omm>` tag (see **8.4**).

8.9.6 The OMM `<body>` shall consist of a single `<segment>`.

8.9.7 The `<segment>` shall consist of a `<metadata>` section and a `<data>` section.

8.9.8 The keywords in the `<metadata>` and `<data>` sections shall be those specified in Section 4. The rules for including any of the keyword tags in the OMM/XML are the same as those specified for the OMM/KVN in Section 4.

8.9.9 Tags for keywords specified in Section 4 shall be all uppercase.

8.9.10 Several of the OMM/XML keywords may have the unit attribute.

8.9.11 In all cases, the units shall match those defined in the tables in Section 4.

8.9.12 The following table lists examples of the use of units in the OMM/XML.

Keyword	Units	Example
BSTAR	1/ER	<code><BSTAR units="1/ER">numeric-value</BSTAR></code>
INCLINATION	deg	<code><INCLINATION units="deg">numeric-value</INCLINATION></code>
MASS	kg	<code><MASS units="kg">numeric-value</MASS></code>
SEMI_MAJOR_AXIS	km	<code><SEMI_MAJOR_AXIS units="km">numeric-value</SEMI_MAJOR_AXIS></code>
MEAN_MOTION	rev/day	<code><MEAN_MOTION units="rev/day">numeric-value</MEAN_MOTION></code>
INCLINATION	deg	<code><INCLINATION units="deg">numeric-value</INCLINATION></code>
GM	km ³ /s ²	<code><GM units="km³/s²">numeric-value</GM></code>
MASS	kg	<code><MASS units="kg">numeric-value</MASS></code>
SOLAR_RAD_AREA	m ²	<code><SOLAR_RAD_AREA units="m²">numeric-value</SOLAR_RAD_AREA></code>
BSTAR	1/ER	<code><BSTAR units="1/ER">numeric-value</BSTAR></code>
MEAN_MOTION_DOT	rev/day ²	<code><MEAN_MOTION_DOT units="rev/day²">numeric-value</MEAN_MOTION_DOT></code>
CX_X	km ²	<code><CX_X units="km²">numeric-value</CX_X></code>
CX_DOT_X	km ² /s	<code><CX_DOT_X units="km²/s">numeric-value</CX_DOT_X></code>

Keyword	Units	Example
CX_DOT_X_DOT	km**2/s**2	<CX_DOT_X_DOT units="km**2/s**2">numeric-value</CX_DOT_X_DOT>
GM	km**3/s**2	<GM units="km**3/s**2">numeric-value</GM>
SOLAR_RAD_AREA	m**2	<SOLAR_RAD_AREA units="m**2">numeric-value</SOLAR_RAD_AREA>
MEAN_MOTION	rev/day	<MEAN_MOTION units="rev/day">numeric-value</MEAN_MOTION>
MEAN MOTION DOT	rev/day**2	<MEAN MOTION DOT units="rev/day**2">numeric-value</MEAN MOTION DOT>

8.9.13 In addition to the OMM keywords specified in Section 4, there are several special tags associated with the OMM body as described in the next few ~~Sections~~sections. The information content in the OMM is separated into constructs described in Section 4 as ‘logical blocks’. Special tags in the OMM are used to encapsulate the information in the logical blocks of the OMM.

8.9.14 The OMM/XML tags used to delimit the logical blocks of the OMM shall be drawn from the following table:

OMM Logical Block	Associated ODM/XML OMM Tag
Mean Keplerian Elements	<meanElements>
Spacecraft Parameters	<spacecraftParameters>
TLE Parameters	<tleParameters>
Covariance Matrix	<covarianceMatrix>
User Defined Parameters	<userDefinedParameters>—(see 8.??)

8.9.15 Between the begin tag and end tag (i.e., between <spacecraftParameters> and </spacecraftParameters>), the user must place the keywords required by the specific logical block as specified in Section 4.

8.10 CREATING AN OEM INSTANTIATION

8.10.1 An OEM instantiation shall be delimited with the `<oem></oem>` root element tags using the standard attributes documented in 8.3.

8.10.2 The final attributes of the `<oem>` tag shall be 'id' and 'version'.

8.10.3 The 'id' attribute shall be 'id="CCSDS_OEM_VERS"'.

8.10.4 The 'version' attribute for the version of the OEM described in Section 5 shall be 'version="3.0"'.

8.10.5 The standard NDM header shall follow the `<oem>` tag (see 8.4).

8.10.6 The OEM `<body>` shall consist of one or more `<segment>` constructs.

8.10.7 Each `<segment>` shall consist of a `<metadata>` section and a `<data>` section.

8.10.8 The keywords in the `<metadata>` and `<data>` sections shall be those specified in Section 5. The rules for including any of the keyword tags in the OEM/XML are the same as those specified for the OEM/KVN in Section 5.

8.10.9 Tags for keywords specified in Section 5 shall be all uppercase.

8.10.10 Several of the OEM/XML keywords may have the unit attribute.

8.10.11 In all cases, the units shall match those defined in Section 5.

8.10.12 In addition to the OEM keywords specified in Section 5, there are some special tags associated with the OEM body as described in the next Sections.

8.10.13 The `<stateVector>` tag shall encapsulate the keywords associated with one of the ephemeris data lines in the OEM.

8.10.14 In the XML representation of the OEM, the components of the `<stateVector>` ephemeris data line must be represented with keywords (i.e., a tag).

8.10.15 The `<stateVector>` keywords shall be the same as those defined for the same construct in the OPM.

8.10.16 The OEM/XML tags used within the `<stateVector>` structure shall be drawn from the following table:

OEM Tag	Represents	Example
<EPOCH>	time tag of the state	<EPOCH>2007-09-20T17:41:00</EPOCH>
<X>	x component of position	<X units="km">6678.0</X>
<Y>	y component of position	<Y units="km">0.0</Y>
<Z>	z component of position	<Z units="km">0.0</Z>
<X_DOT>	x component of velocity	<X_DOT units="km/s">0</X_DOT>
<Y_DOT>	y component of velocity	<Y_DOT units="km/s">7.73</Y_DOT>
<Z_DOT>	z component of velocity	<Z_DOT units="km/s">0.0</Z_DOT>
<X_DDOT>	x component of acceleration	<X_DDOT units="km/s**2">0.0</X_DDOT>
<Y_DDOT>	y component of acceleration	<Y_DDOT units="km/s**2">0.50</Y_DDOT>
<Z_DDOT>	z component of acceleration	<Z_DDOT units="km/s**2">0.0</Z_DDOT>

8.10.17 Between the begin tag and end tag (i.e., between <stateVector> and </stateVector>), the user shall place the values required by the ephemeris data line as specified in Section 5.

8.10.18 Since the state vector structure is shared by the OPM schema and OEM schema, units may optionally appear in the XML version of the OEM ephemeris data line.

8.10.19 The <covarianceMatrix> tag shall encapsulate the keywords associated with the covariance matrix lines in the OEM.

8.10.20 In the XML representation of the OEM, the covariance data line must be represented with keywords (i.e., a tag).

8.10.21 The OEM <covarianceMatrix> keywords shall be the same as those defined for the same construct in the OPM and OMM.

NOTE – In the KVN representations of the OEM covariance matrix data lines, keywords are not used. Rather, the components of the covariance matrix data line appear in an order defined in Section 5. Similarly, units are not used in the KVN version of the OEM covariance matrix; however, they are optional in the OPM and OMM.

8.10.22 Since the covariance matrix structure is shared by the OPM, OMM, and OEM, units may optionally appear in the XML version of the OEM covariance matrix line.

8.10.23 The OEM/XML tags used within the <covarianceMatrix> structure shall be drawn from the following table:

Keyword	Units	Example
CX_X, CY_X, CY_Y, CZ_X, CZ_Y, CZ_Z	km**2	<CX_X units="km**2">numeric-value</CX_X>
CX_DOT_X, CX_DOT_Y, CX_DOT_Z, CY_DOT_X, CY_DOT_Y, CY_DOT_Z, CZ_DOT_X, CZ_DOT_Y, CZ_DOT_Z	km**2/s	<CX_DOT_X units="km**2/s">numeric-value</CX_DOT_X>
CX_DOT_X_DOT, CY_DOT_X_DOT, CY_DOT_Y_DOT, CZ_DOT_X_DOT, CZ_DOT_Y_DOT, CZ_DOT_Z_DOT	km**2/s**2	<CX_DOT_X_DOT units="km**2/s**2">numeric-value</CX_DOT_X_DOT>

8.10.24 Between the begin tag and end tag (i.e., between <covarianceMatrix> and </covarianceMatrix>), the user shall place the values required by the covariance matrix line type as specified in Section 5.

8.11 CREATING AN OCM INSTANTIATION

8.11.1 An OCM instantiation shall be delimited with the `<ocm></ocm>` root element tags using the standard attributes documented in 8.3.

8.11.2 The final attributes of the `<ocm>` tag shall be 'id' and 'version'.

8.11.3 The 'id' attribute shall be 'id="CCSDS_OCM_VERS"'.

8.11.4 The 'version' attribute for the version of the OCM described in Section 6 shall be 'version="3.0"'.

8.11.5 The standard NDM header shall follow the `<ocm>` tag (see 8.4).

8.11.6 The OCM `<body>` shall consist of a single `<segment>` construct.

8.11.7 The `<segment>` shall consist of a `<metadata>` section and a `<data>` section.

8.11.8 The keywords in the `<metadata>` and `<data>` sections shall be those specified in Section 6. The rules for including any of the keyword tags in the OCM/XML are the same as those specified for the OCM in Section 6.

8.11.9 Tags for keywords specified in Section 6 shall be all uppercase.

8.11.10 Several of the OCM/XML keywords may have the unit attribute.

8.11.11 In all cases, the units shall match those defined in the tables in Section 6, including orbit, covariance and maneuver data units as specified by ORB_UNITS, COV_UNITS, and MAN_UNITS, respectively.

8.9.16 The following table lists examples of the use of units in the OCM/XML.

Keyword	Units	Example
<u>ACTUAL_OD_SPAN</u>	<u>d</u>	<code><ACTUAL_OD_SPAN units="d">numeric-value</ACTUAL_OD_SPAN></code>
<u>DC_PA_START_ANGLE</u>	<u>deg</u>	<code><DC_PA_START_ANGLE units="deg">numeric-value</DC_PA_START_ANGLE></code>
<u>CENTRAL_BODY_ROTATION</u>	<u>deg/s</u>	<code><CENTRAL_BODY_ROTATION units="deg/s">numeric-value</CENTRAL_BODY_ROTATION></code>
<u>MASS</u>	<u>kg</u>	<code><MASS units="kg">numeric-value</MASS></code>
<u>IXX</u>	<u>kg*m**2</u>	<code><IXX units="kg*m**2">numeric-value</IXX></code>
<u>EQUATORIAL_RADIUS</u>	<u>km</u>	<code><EQUATORIAL_RADIUS units="km">numeric-value</EQUATORIAL_RADIUS></code>
<u>GM</u>	<u>km**3/s**2</u>	<code><GM units="km**3/s**2">numeric-value</GM></code>
<u>DV_BOL</u>	<u>km/s</u>	<code><DV_BOL units="km/s">numeric-value</DV_BOL></code>
<u>OEB_MAX</u>	<u>m</u>	<code><OEB_MAX units="m">numeric-value</OEB_MAX></code>
<u>DRAG_ADDL_AREA</u>	<u>m**2</u>	<code><DRAG_ADDL_AREA units="m**2">numeric-value</DRAG_ADDL_AREA></code>
<u>MAX_THRUST</u>	<u>N</u>	<code><MAX_THRUST units="N">numeric-value</MAX_THRUST></code>
<u>FIXED_GEOMAG_KP</u>	<u>nT</u>	<code><FIXED_GEOMAG_KP units="nT">numeric-value</FIXED_GEOMAG_KP></code>

<u>Keyword</u>	<u>Units</u>	<u>Example</u>
<u>UT1MUTC_AT_TZERO</u>	<u>s</u>	<u><UT1MUTC_AT_TZERO units="s">numeric-value</UT1MUTC_AT_TZERO></u>
<u>FIXED_F10P7</u>	<u>SFU</u>	<u><FIXED_F10P7 units="SFU">numeric-value</FIXED_F10P7></u>
<u>DRAG_UNCERTAINTY</u>	<u>%</u>	<u><DRAG_UNCERTAINTY units="%">numeric-value</DRAG_UNCERTAINTY></u>

8.11.12 In addition to the OCM keywords specified in Section 6, there are some special tags associated with the OCM body as described in the next Sections.

<u>OCM Section</u> <u>Logical Block</u>	<u>Associated ODM/XML OCM</u> <u>TagSection Tags</u>	<u>Data Line Tag</u>
Orbit Data	<u><orbitStateorb></u>	<u><orbitLinesorbLine></u>
Space Object Physical <u>DescriptionCharacteristics</u>	<u><physicalDescription><phys</u> <u>></u>	N/A
Covariance Data	<u><covarianceMatrixcov></u>	<u><covarianceLinescovL</u> <u>ine></u>
<u>State Transition Matrix Data</u>	<u><stateTransitionMatrix></u>	<u><stmLines</u>
Maneuver Data	<u><maneuverParameters><m</u> <u>an></u>	<u>maneuverLines<manL</u> <u>ine></u>
Perturbations Parameters	<u><perturbationspert></u>	N/A
Orbit Determination Data	<u><odParametersod></u>	N/A
User-Defined Parameters	<u><userDefinedParameters><</u> <u>user></u>	N/A

8.10.25 In the XML representation of the OCM, the tbd data line must be represented with keywords (i.e., a tag). — [NOTE TO DAN: We should discuss whether we depend on the user to parse a string delimited with spaces (e.g., an "orbitLine") based on the ORB_TYPE selected from the SANA registry, or whether we want to develop the XML tags for all of those orbit types (and the several other data lines that have complex structure). Right now in the schema I have "orbitLine", "maneuverLine", "covarianceLine", "stmLine" as a tag, after which is an unstructured string (structure supplied according to the applicable registry). It will be a huge job to break all those apart in XML. Could be done, but want to discuss before embarking on that path.]

8.11.13 Between the begin tag and end tag (e.g., between <orb> and </orb>), the user must place the keywords required by the specific OCM section as specified in Section 6.

8.11.14 The data type of the <orbLine>, <covLine>, and <manLine> elements is "xsd:string", i.e., there is no validation of the contents and the line must be parsed by the OCM recipient to access the individual components of the orbit, covariance, or maneuver data line.

8.11.15 The number of individual components in the multipartite <orbLine> shall be determined by the number of components in the value for the ORB_TYPE keyword, plus one for the timetag.

8.11.16 The number of individual components in the single multipartite <covLine> shall be 12 if COV TYPE=EIGVAL3EIGVEC3 is selected, or 13 if COV TYPE=TEIGVAL3EIGVEC3 is selected. Otherwise, if "N" is the dimension of the covariance matrix, then the number of individual components in the single multipartite <covLine> shall be $(N^2+N)/2$, plus one for the timetag.

8.11.17 The number of individual components in the multipartite <manLine> shall be determined by the number of comma-separated values in the MAN_COMPOSITION keyword, plus one for the timetag.

8.12 CREATING A COMBINED INSTANTIATION

8.12.1 An ODM user may create an XML instance that incorporates any number of messages from sections 3 through 6 of this document in a logical suite called an 'NDM (Navigation Data Message) Combined Instantiation'. Such combined instantiations may be useful for some situations, for example:

- A maneuver scenario where both "no burn" ephemeris and "with burn" ephemeris are combined in a single message.
- A constellation scenario where states (OPM, OMM) and/or ephemeris data (OEM, OCM) for all the spacecraft in the constellation are combined in a single XML message.
- A full OEM or OCM ephemeris with detail on important states reflected in some number of OPMs. The OEM/OCM and the multiple OPMs can be conveniently conveyed in a single NDM.

8.12.2 An NDM combined instantiation shall be delimited with the <ndm></ndm> root element tags instead of one of the individual message tags described in 8.3.2

8.12.3 The standard attributes documented in 8.3 shall be used with the <ndm> tag, with the exception that neither 'id' nor 'version' attributes are associated with the <ndm> tag.

8.12.4 In the NDM combined instantiation, the only attributes that shall appear on the constituent message tags (i.e., the tags listed in 8.3.2) are the 'id' and 'version' attributes.

8.12.5 Between the <ndm></ndm> tags, the desired messages described in 8.8 through 8.11 may be combined as needed to meet user requirements.

8.12.6 Any combination of constituent ODM message types may be used in an NDM combined instantiation.

8.12.7 Figure 8-1 and Figure 8-2 illustrate the basic structure of an NDM combined instantiation. All detail has been removed from Figure 8-1 in order to contrast the single message ODM with an NDM combined instantiation. As shown in Figure 8-2, in an NDM combined instantiation the individual message tags still have the 'id' and 'version' attributes, but the namespace attributes and schema location attributes are associated with the <ndm> root element.

<u>Single Message OPM</u>	<u>NDM Combined Instantiation</u>
<pre> <u><opm></u> <u> <header></u> <u></header></u> <u> <body></u> <u></body></u> <u></opm></u> </pre>	<pre> <u><ndm></u> <u> <opm></u> <u> <header></u> <u> </header></u> <u> <body></u> <u> </body></u> <u> </opm></u> <u> .</u> <u> .</u> <u> .</u> <u> <opm></u> <u> <header></u> <u> </header></u> <u> <body></u> <u> </body></u> <u> </opm></u> <u></ndm></u> </pre>

Figure 8-2: Comparison of Single Message OPM with NDM Combined Instantiation

8.12.8 The OPMs shown in Figure 8-2 may be replaced with any number of OMM, OEM, or OCM messages in any combination as needed to meet user requirements, as shown in Figure 8-3 below.

```

<?xml version="1.0" encoding="UTF-8"?>
<ndm xmlns:xsi="http://www.w3.org/2001/XMLSchema-instance"
      xsi:noNamespaceSchemaLocation="https://sanaregistry.org/r/ndmxml/ndmxml-1.0-
      master.xsd">

<COMMENT>This figure combines multiple ODM/XML messages into a single message</COMMENT>
<COMMENT>Message detail is deleted in order to focus on the message structure</COMMENT>
<COMMENT>Note use of "<ndm>" root element, and ODM message/version attributes</COMMENT>

  <opm id="CCSDS_OPM_VERS" version="3.0">
    <header>
    </header>
    <body>
    </body>
  </opm>

  <oem id="CCSDS_OEM_VERS" version="3.0">
    <header>
    </header>
    <body>
    </body>
  </oem>

  <opm id="CCSDS_OPM_VERS" version="3.0">
    <header>
    </header>
    <body>
    </body>
  </opm>

  <omm id="CCSDS_OMM_VERS" version="3.0">
    <header>
    </header>
    <body>
    </body>
  </omm>

  <ocm id="CCSDS_OCM_VERS" version="3.0">
    <header>
    </header>
    <body>
    </body>
  </ocm>

</ndm>

```

Figure 8-3: NDM Combined Instantiation Showing Mix of ODMs and Use of Attributes

NOTE: See Fig. H-1 for a full example of one use case combining multiple ODMs in a single XML message. For instructions on creating a combined instantiation, ~~e.g., one~~ that incorporates ~~multiple~~ ODM/XML messages ~~or an ODM/XML message~~ combined with other navigation related messages, see reference [\[5\]](#).

8.13 SPECIAL SYNTAX RULES FOR ODM/XML

8.13.1 Most of the KVN syntax rules apply for ODM/XML instantiations of an ODM, however, there are a few variations described in this section that shall be observed.

8.13.2 Each mandatory XML tag must be present and contain a valid value.

8.13.3 Integer values shall follow the conventions of the integer data type per Reference [12]. Additional restrictions on the allowable range of values permitted for any integer data element may also be defined in the ODM/XML Schema.

NOTE – Examples of such restrictions may include a defined range (e.g., 0 - 100, 1 - 10, etc.), a set of enumerated values (e.g., 0,1,2,4+,8), a pre-defined specific variation such as positiveInteger, or a user-defined data type variation.

8.13.4 Non-integer numeric values may be expressed in either fixed-point or floating-point notation. Numeric values shall follow the conventions of the double data type per Reference [13]. Additional restrictions on the allowable range of values permitted for any numeric data element may also be defined in the ODM/XML Schema.

NOTE – Examples of such restrictions may include a defined range (e.g., 0.0-100.0, etc.), or a user-defined data type variation.

8.13.5 Text values shall follow the conventions of the string data type per Reference [14]. Additional restrictions on the allowable range or values permitted for any data element may also be defined in the ODM/XML Schema.

NOTE – Examples of such restrictions may include a set of enumerated values (e.g., 'YES'/'NO') or other user-defined data type variation.

8.13.6 The units in the ODM/XML shall be the same units used in the KVN-formatted ODM described in Section 7.6.3, or via the mandatory ORB UNITS, COV UNITS and/or MAN UNITS keywords contained in Table 6-4, Table 6-6, and/or Table 6-7 respectively. XML attributes shall be used to explicitly define the units or other important information associated with the given data element. See the tables in this section for the OPM, OMM, OEM, and OCM for examples of coding units in ODM/XML instantiations.

8.13.7 Comments must be displayed as values between the <COMMENT> and </COMMENT> tags.

ANNEX A

IMPLEMENTATION CONFORMANCE**STATEMENT PRO FORMA****(NORMATIVE)****A1 INTRODUCTION****A1.1 OVERVIEW**

This annex provides the Implementation Conformance Statement (ICS) Requirements List (RL) for an implementation of the Orbit Data Messages (CCSDS 502.0). The ICS for an implementation is generated by completing the RL in accordance with the instructions below. An implementation shall satisfy the mandatory conformance requirements referenced in the RL.

- The RL in this annex is blank. An implementation's completed RL is called the ICS. The ICS states which capabilities and options have been implemented. The following can use the ICS:
 - the implementer, as a checklist to reduce the risk of failure to conform to the standard through oversight;
 - a supplier or potential acquirer of the implementation, as a detailed indication of the capabilities of the implementation, stated relative to the common basis for understanding provided by the standard ICS proforma;
 - a user or potential user of the implementation, as a basis for initially checking the possibility of interworking with another implementation (it should be noted that, while interworking can never be guaranteed, failure to interwork can often be predicted from incompatible ICS lists);
 - a tester, as the basis for selecting appropriate tests against which to assess the claim for conformance of the implementation.

A1.2 ABBREVIATIONS AND CONVENTIONS

The RL consists of information in tabular form. The status of features is indicated using the abbreviations and conventions described below.

Item Column

The item column contains sequential numbers for items in the table.

Feature Column

The feature column contains a brief descriptive name for a feature. It implicitly means “Is this feature supported by the implementation?”

Status Column

The status column uses the following notations:

- M mandatory;
- O optional;
- C conditional;
- X prohibited;
- I out of scope;
- N/A not applicable.

Support Column Symbols

The support column is to be used by the implementer to state whether a feature is supported by entering Y, N, or N/A, indicating:

- Y Yes, supported by the implementation.
- N No, not supported by the implementation.
- N/A Not applicable.

The support column should also be used, when appropriate, to enter values supported for a given capability.

A1.3 INSTRUCTIONS FOR COMPLETING THE RL

An implementer shows the extent of compliance to the Recommended Standard by completing the RL; that is, the state of compliance with all mandatory requirements and the options supported are shown. The resulting completed RL is called an ICS. The implementer shall complete the RL by entering appropriate responses in the support or values supported column, using the notation described in A1.2. If a conditional requirement is inapplicable, N/A should be used. If a mandatory requirement is not satisfied, exception information must be supplied by entering a reference X_i , where i is a unique identifier, to an accompanying rationale for the noncompliance.

A2 ICS PROFORMA FOR ORBIT DATA MESSAGES

A2.1 IDENTIFICATION OF ICS

Date of Statement (DD/MM/YYYY)	
ICS serial number	
System Conformance statement cross-reference	

A2.2 IDENTIFICATION OF IMPLEMENTATION UNDER TEST (IUT)

Implementation name	
Implementation version	
Special Configuration	
Other Information	

A2.3 IDENTIFICATION OF SUPPLIES

Supplier	
Contact Point for Queries	
Implementation Name(s) and Versions	
Other information necessary for full identification, e.g., name(s) and version(s) for machines and/or operating systems; System Name(s)	

A2.4 DOCUMENT VERSIONS

CCSDS 502.0 Document Version	3
<p>Have any exceptions been required?</p> <p>(Note: A YES answer means that the implementation does not conform to the Recommended Standard. Non-supported mandatory capabilities are to be identified in the ICS, with an explanation of why the implementation is non-conforming.)</p>	Yes _____ No_____

A2.5 REQUIREMENTS LISTS

[See CCSDS A20.1-Y-1, *CCSDS Implementation Conformance Statements* (Yellow Book, Issue 1, April 2014).]

A2.6 ORBIT PARAMETER MESSAGE REQUIREMENTS LIST

Note to Tom Gannett: ~~this section~~these sections should probably be A2.5.1 etc. (Annex level three) but the line type is not defined and I'm not confident I know how to do that.

Note 2 to Tom Gannett: Would it be okay to highlight in BLUE or otherwise denote (with a bolder row-wise border) the separate data blocks as I've done below?

Item	Feature	Keyword	Reference	Status (M/O)/C	Support
1	OPM Header	N/A	Table 3-1	M	
2	OPM Version	CCSDS_OPM_VERS	Table 3-1	M	
3	Comment	COMMENT	Table 3-1	O	
4	Message creation date and time	CREATION_DATE	Table 3-1	M	
5	Message originator	ORIGINATOR	Table 3-1	M	
6	Unique message identifier	MESSAGE_ID	Table 3-1	O	
7	OPM Metadata	N/A	Table 3-2	M	
8	Comment	COMMENT	Table 3-2	O	
9	Name of space object	OBJECT_NAME	Table 3-2	M	
10	Identifier of space object	OBJECT_ID	Table 3-2	M	
11	Orbit center	CENTER_NAME	Table 3-2	M	
12	Reference frame	REF_FRAME	Table 3-2	M	
13	Epoch of reference frame	REF_FRAME_EPOCH	Table 3-2	O	
14	Time system applicable to data	TIME_SYSTEM	Table 3-2	M	
15	OPM Data	N/A	Table 3-3	M	
16	State Vector logical block	N/A	Table 3-3	M	
17	Comment	COMMENT	Table 3-3	O	
18	Epoch of the state vector	EPOCH	Table 3-3	M	
19	X component of position	X	Table 3-3	M	
20	Y component of position	Y	Table 3-3	M	
21	Z component of position	Z	Table 3-3	M	
22	X component of velocity	X_DOT	Table 3-3	M	
23	Y component of velocity	Y_DOT	Table 3-3	M	

CCSDS PROPOSED STANDARD FOR ORBIT DATA MESSAGES

24	Z component of velocity	Z_DOT	Table 3-3	M	
25	Keplerian Elements logical block	N/A	Table 3-3	M	
26	Comment	COMMENT	Table 3-3	O	
27	Semi-major axis of orbit	SEMI_MAJOR_AXIS	Table 3-3	O	
28	Eccentricity of orbit	ECCENTRICITY	Table 3-3	O	
29	Inclination of orbit	INCLINATION	Table 3-3	O	
30	Right ascension of ascending node of orbit	RA_OF_ASC_NODE	Table 3-3	O	
31	Argument of pericenter of orbit	ARG_OF_PERICENTER	Table 3-3	O	
32	True or mean anomaly of orbit	TRUE_ANOMALY—or MEAN_ANOMALY	Table 3-3	O	
33	Gravitational coefficient of the central body	GM	Table 3-3	O	
34	Spacecraft Parameters logical block	N/A	Table 3-3	M	
35	Comment	COMMENT	Table 3-3	O	
36	Mass of the spacecraft	MASS	Table 3-3	O	
37	Solar radiation area of the spacecraft	SOLAR_RAD_AREA	Table 3-3	O	
38	Solar radiation coefficient of the spacecraft	SOLAR_RAD_COEFF	Table 3-3	O	
39	Drag area of the spacecraft	DRAG_AREA	Table 3-3	O	
40	Drag coefficient of the spacecraft	DRAG_COEFF	Table 3-3	O	
41	Position/velocity Covariance Matrix logical block	N/A	Table 3-3	O	
42	Covariance matrix [1,1]	GX_X	Table 3-3	O	
43	Covariance matrix [2,1]	GY_X	Table 3-3	O	
44	Covariance matrix [2,2]	GY_Y	Table 3-3	O	
45	Covariance matrix [3,1]	GZ_X	Table 3-3	O	
46	Covariance matrix [3,2]	GZ_Y	Table 3-3	O	
47	Covariance matrix [3,3]	GZ_Z	Table 3-3	O	
48	Covariance matrix [4,1]	GX_DOT_X	Table 3-3	O	
49	Covariance matrix [4,2]	GX_DOT_Y	Table 3-3	O	

50	Covariance matrix [4,3]	CX_DOT_Z	Table 3-3	○	
51	Covariance matrix [4,4]	CX_DOT_X_DOT	Table 3-3	○	
52	Covariance matrix [5,1]	CY_DOT_X	Table 3-3	○	
53	Covariance matrix [5,2]	CY_DOT_Y	Table 3-3	○	
54	Covariance matrix [5,3]	CY_DOT_Z	Table 3-3	○	
55	Covariance matrix [5,4]	CY_DOT_X_DOT	Table 3-3	○	
56	Covariance matrix [5,5]	CY_DOT_Y_DOT	Table 3-3	○	
57	Covariance matrix [6,1]	GZ_DOT_X	Table 3-3	○	
58	Covariance matrix [6,2]	GZ_DOT_Y	Table 3-3	○	
59	Covariance matrix [6,3]	GZ_DOT_Z	Table 3-3	○	
60	Covariance matrix [6,4]	GZ_DOT_X_DOT	Table 3-3	○	
61	Covariance matrix [6,5]	GZ_DOT_Y_DOT	Table 3-3	○	
62	Covariance matrix [6,6]	GZ_DOT_Z_DOT	Table 3-3	○	
63	Maneuver Parameters logical block	N/A	Table 3-3	○	
64	Comment	COMMENT	Table 3-3	○	
65	Time-of maneuver start	MAN_EPOCH_IGNITION	Table 3-3	○	
66	Duration of maneuver	MAN_DURATION	Table 3-3	○	
67	Change of mass due to maneuver	MAN_DELTA_MASS	Table 3-3	○	
68	Relevant reference frame for maneuver	MAN_REF_FRAME	Table 3-3	○	
69	X component of velocity change	MAN_DV_1	Table 3-3	○	
70	Y component of velocity change	MAN_DV_2	Table 3-3	○	
71	Z component of velocity change	MAN_DV_3	Table 3-3	○	
72	User Defined Parameters logical block	N/A	Table 3-3	○	
73	As defined by user, "essential information that cannot be conveyed in COMMENT statements"	USER_DEFINED_x	Table 3-3	○	

~~A2.7A1.1 ORBIT MEAN ELEMENTS MESSAGE REQUIREMENTS LIST~~

Note to Tom Gannett: this section should probably be A2.5.2 (Annex level three) but the line type is not defined and I'm not confident I know how to do that.

Item	Feature	Keyword	Reference	Status (M/O)	Support
1	OPM Header	N/A	Table 3-1	M	
2	OPM Version	CCSDS_OPM_VERS	Table 3-1	M	
3	Comment	COMMENT	Table 3-1	O	
4	Message creation date and time	CREATION_DATE	Table 3-1	M	
5	Message originator	ORIGINATOR	Table 3-1	M	
6	Unique message identifier	MESSAGE_ID	Table 3-1	O	
7	OPM Metadata	N/A	Table 3-2	M	
8	Comment	COMMENT	Table 3-2	O	
9	Name of space object	OBJECT_NAME	Table 3-2	M	
10	Identifier of space object	OBJECT_ID	Table 3-2	M	
11	Orbit center	CENTER_NAME	Table 3-2	M	
12	Reference frame	REF_FRAME	Table 3-2	M	
13	Epoch of reference frame	REF_FRAME_EPOCH	Table 3-2	O	
14	Time system applicable to data	TIME_SYSTEM	Table 3-2	M	
15	OPM Data	N/A	Table 3-3	M	
16	State Vector logical block	N/A	Table 3-3	M	
17	Comment	COMMENT	Table 3-3	O	
18	Epoch of the state vector	EPOCH	Table 3-3	M	
19	X component of position	X	Table 3-3	M	
20	Y component of position	Y	Table 3-3	M	
21	Z component of position	Z	Table 3-3	M	
22	X component of velocity	X_DOT	Table 3-3	M	
23	Y component of velocity	Y_DOT	Table 3-3	M	
24	Z component of velocity	Z_DOT	Table 3-3	M	
25	Keplerian Elements logical block	N/A	Table 3-3	M	
26	Comment	COMMENT	Table 3-3	O	
27	Semi-major axis of orbit	SEMI_MAJOR_AXIS	Table 3-3	O	
28	Eccentricity of orbit	ECCENTRICITY	Table 3-3	O	

CCSDS PROPOSED STANDARD FOR ORBIT DATA MESSAGES

29	Inclination of orbit	INCLINATION	Table 3-3	O	
30	Right ascension of ascending node of orbit	RA_OF_ASC_NODE	Table 3-3	O	
31	Argument of pericenter of orbit	ARG_OF_PERICENTER	Table 3-3	O	
32	True or mean anomaly of orbit	TRUE_ANOMALY or MEAN_ANOMALY	Table 3-3	O	
33	Gravitational coefficient of the central body	GM	Table 3-3	O	
34	Spacecraft Parameters logical block	N/A	Table 3-3	M	
35	Comment	COMMENT	Table 3-3	O	
36	Mass of the spacecraft	MASS	Table 3-3	O	
37	Solar radiation area of the spacecraft	SOLAR_RAD_AREA	Table 3-3	O	
38	Solar radiation coefficient of the spacecraft	SOLAR_RAD_COEFF	Table 3-3	O	
39	Drag area of the spacecraft	DRAG_AREA	Table 3-3	O	
40	Drag coefficient of the spacecraft	DRAG_COEFF	Table 3-3	O	
41	Position/velocity Covariance Matrix logical block	N/A	Table 3-3	O	
<u>42</u>	<u>Comment</u>	<u>COMMENT</u>	<u>Table 3-3</u>	<u>O</u>	
<u>43</u>	<u>COV_REF_FRAME</u>	<u>COMMENT</u>	<u>Table 3-3</u>	<u>O</u>	
<u>4244</u>	Covariance matrix [1,1]	CX_X	Table 3-3	O	
<u>4345</u>	Covariance matrix [2,1]	CY_X	Table 3-3	O	
<u>4446</u>	Covariance matrix [2,2]	CY_Y	Table 3-3	O	
<u>4547</u>	Covariance matrix [3,1]	CZ_X	Table 3-3	O	
<u>4648</u>	Covariance matrix [3,2]	CZ_Y	Table 3-3	O	
<u>4749</u>	Covariance matrix [3,3]	CZ_Z	Table 3-3	O	
<u>4850</u>	Covariance matrix [4,1]	CX_DOT_X	Table 3-3	O	
<u>4951</u>	Covariance matrix [4,2]	CX_DOT_Y	Table 3-3	O	
<u>5052</u>	Covariance matrix [4,3]	CX_DOT_Z	Table 3-3	O	
<u>5153</u>	Covariance matrix [4,4]	CX_DOT_X_DOT	Table 3-3	O	
<u>5254</u>	Covariance matrix [5,1]	CY_DOT_X	Table 3-3	O	

5355	Covariance matrix [5,2]	CY_DOT_Y	Table 3-3	O	
5456	Covariance matrix [5,3]	CY_DOT_Z	Table 3-3	O	
5557	Covariance matrix [5,4]	CY_DOT_X_DOT	Table 3-3	O	
5658	Covariance matrix [5,5]	CY_DOT_Y_DOT	Table 3-3	O	
5759	Covariance matrix [6,1]	CZ_DOT_X	Table 3-3	O	
5860	Covariance matrix [6,2]	CZ_DOT_Y	Table 3-3	O	
5961	Covariance matrix [6,3]	CZ_DOT_Z	Table 3-3	O	
6062	Covariance matrix [6,4]	CZ_DOT_X_DOT	Table 3-3	O	
6163	Covariance matrix [6,5]	CZ_DOT_Y_DOT	Table 3-3	O	
6264	Covariance matrix [6,6]	CZ_DOT_Z_DOT	Table 3-3	O	
6365	Maneuver Parameters logical block	N/A	Table 3-3	O	
6466	Comment	COMMENT	Table 3-3	O	
6567	Time of maneuver start	MAN_EPOCH_IGNITION	Table 3-3	O	
6668	Duration of maneuver	MAN_DURATION	Table 3-3	O	
6769	Change of mass due to maneuver	MAN_DELTA_MASS	Table 3-3	O	
6870	Relevant reference frame for maneuver	MAN_REF_FRAME	Table 3-3	O	
6971	X 1 st component of velocity change	MAN_DV_1	Table 3-3	O	
7072	Y 2 nd component of velocity change	MAN_DV_2	Table 3-3	O	
7173	Z 3 rd component of velocity change	MAN_DV_3	Table 3-3	O	
7274	User Defined Parameters logical block	N/A	Table 3-3	O	
7375	As defined by user, "essential information that cannot be conveyed in COMMENT statements"	USER_DEFINED_x	Table 3-3	O	

A2.7 ORBIT MEAN ELEMENTS MESSAGE REQUIREMENTS LIST

CCSDS PROPOSED STANDARD FOR ORBIT DATA MESSAGES

<u>Item</u>	<u>Feature</u>	<u>Keyword</u>	<u>Reference</u>	<u>Status M/O/C</u>	<u>Support</u>
<u>1</u>	<u>OMM Header</u>	<u>N/A</u>	<u>Table 4-1</u>	<u>M</u>	
<u>2</u>	<u>OMM Version</u>	<u>CCSDS_OMM_VERS</u>	<u>Table 4-1</u>	<u>M</u>	
<u>3</u>	<u>Comment</u>	<u>COMMENT</u>	<u>Table 4-1</u>	<u>O</u>	
<u>4</u>	<u>Message creation date and time</u>	<u>CREATION_DATE</u>	<u>Table 4-1</u>	<u>M</u>	
<u>5</u>	<u>Message originator</u>	<u>ORIGINATOR</u>	<u>Table 4-1</u>	<u>M</u>	
<u>6</u>	<u>Unique message identifier</u>	<u>MESSAGE_ID</u>	<u>Table 4-1</u>	<u>O</u>	
<u>7</u>	<u>OMM Metadata</u>	<u>N/A</u>	<u>Table 4-2</u>	<u>M</u>	
<u>8</u>	<u>Comment</u>	<u>COMMENT</u>	<u>Table 4-2</u>	<u>O</u>	
<u>9</u>	<u>Name of space object</u>	<u>OBJECT_NAME</u>	<u>Table 4-2</u>	<u>M</u>	
<u>10</u>	<u>Identifier of space object</u>	<u>OBJECT_ID</u>	<u>Table 4-2</u>	<u>M</u>	
<u>11</u>	<u>Orbit center</u>	<u>CENTER_NAME</u>	<u>Table 4-2</u>	<u>M</u>	
<u>12</u>	<u>Reference frame</u>	<u>REF_FRAME</u>	<u>Table 4-2</u>	<u>M</u>	
<u>13</u>	<u>Epoch of reference frame</u>	<u>REF_FRAME_EPOCH</u>	<u>Table 4-2</u>	<u>O</u>	
<u>14</u>	<u>Time system applicable to data</u>	<u>TIME_SYSTEM</u>	<u>Table 4-2</u>	<u>M</u>	
<u>15</u>	<u>Mean element set theory of data</u>	<u>MEAN_ELEMENT_THEORY</u>	<u>Table 4-2</u>	<u>M</u>	
<u>16</u>	<u>OMM Data</u>	<u>N/A</u>	<u>Table 4-3</u>	<u>M</u>	
<u>17</u>	<u>Mean Keplerian elements logical block</u>	<u>N/A</u>	<u>Table 4-3</u>	<u>M</u>	
<u>18</u>	<u>Comment</u>	<u>COMMENT</u>	<u>Table 4-3</u>	<u>O</u>	
<u>19</u>	<u>Epoch of the state vector</u>	<u>EPOCH</u>	<u>Table 4-3</u>	<u>M</u>	
<u>20</u>	<u>Semi-major axis or mean motion</u>	<u>SEMI_MAJOR_AXIS</u> or <u>MEAN_MOTION</u>	<u>Table 4-3</u>	<u>M</u>	
<u>21</u>	<u>Eccentricity</u>	<u>ECCENTRICITY</u>	<u>Table 4-3</u>	<u>M</u>	
<u>22</u>	<u>Inclination</u>	<u>INCLINATION</u>	<u>Table 4-3</u>	<u>M</u>	
<u>23</u>	<u>Right ascension of ascending node</u>	<u>RA_OF_ASC_NODE</u>	<u>Table 4-3</u>	<u>M</u>	
<u>24</u>	<u>Argument of pericenter</u>	<u>ARG_OF_PERICENTER</u>	<u>Table 4-3</u>	<u>M</u>	
<u>25</u>	<u>Mean anomaly</u>	<u>MEAN_ANOMALY</u>	<u>Table 4-3</u>	<u>M</u>	
<u>26</u>	<u>Gravitational Coefficient</u>	<u>GM</u>	<u>Table 4-3</u>	<u>O</u>	
<u>27</u>	<u>Spacecraft Parameters logical block</u>	<u>N/A</u>	<u>Table 4-3</u>	<u>O</u>	
<u>28</u>	<u>Comment</u>	<u>COMMENT</u>	<u>Table 4-3</u>	<u>O</u>	
<u>29</u>	<u>Spacecraft Mass</u>	<u>MASS</u>	<u>Table 4-3</u>	<u>O</u>	
<u>30</u>	<u>Solar Radiation Pressure Area</u>	<u>SOLAR_RAD_AREA</u>	<u>Table 4-3</u>	<u>O</u>	
<u>31</u>	<u>Solar Radiation Pressure Coefficient</u>	<u>SOLAR_RAD_COEFF</u>	<u>Table 4-3</u>	<u>O</u>	

CCSDS PROPOSED STANDARD FOR ORBIT DATA MESSAGES

32	<u>Drag Area</u>	<u>DRAG_AREA</u>	<u>Table 4-3</u>	<u>O</u>	
33	<u>Drag Coefficient</u>	<u>DRAG_COEFF</u>	<u>Table 4-3</u>	<u>O</u>	
34	<u>TLE logical block</u>	<u>N/A</u>	<u>Table 4-3</u>	<u>O</u>	
35	<u>Comment</u>	<u>COMMENT</u>	<u>Table 4-3</u>	<u>O</u>	
36	<u>Ephemeris Type</u>	<u>EPHEMERIS_TYPE</u>	<u>Table 4-3</u>	<u>O</u>	
37	<u>Classification Type</u>	<u>CLASSIFICATION_TYPE</u>	<u>Table 4-3</u>	<u>O</u>	
38	<u>NORAD Catalog Number</u>	<u>NORAD_CAT_ID</u>	<u>Table 4-3</u>	<u>O</u>	
39	<u>Element set number</u>	<u>ELEMENT_SET_NO</u>	<u>Table 4-3</u>	<u>O</u>	
40	<u>Revolution Number</u>	<u>REV_AT_EPOCH</u>	<u>Table 4-3</u>	<u>O</u>	
41	<u>SGP/SGP4 drag-like coefficient</u>	<u>BSTAR</u>	<u>Table 4-3</u>	<u>O</u>	
42	<u>First Time Derivative of the Mean Motion</u>	<u>MEAN_MOTION_DOT</u>	<u>Table 4-3</u>	<u>O</u>	
43	<u>Second Time Derivative of Mean Motion</u>	<u>MEAN_MOTION_DDOT</u>	<u>Table 4-3</u>	<u>O</u>	
44	<u>Pos/Vel/Cov logical block</u>		<u>Table 4-3</u>	<u>O</u>	
45	<u>Comment</u>	<u>COMMENT</u>	<u>Table 4-3</u>	<u>O</u>	
46	<u>Cov reference frame</u>	<u>COV_REF_FRAME</u>	<u>Table 4-3</u>	<u>O</u>	
47	<u>Covariance[1,1]</u>	<u>CX_X</u>	<u>Table 4-3</u>	<u>O</u>	
48	<u>Covariance[2,1]</u>	<u>CY_X</u>	<u>Table 4-3</u>	<u>O</u>	
49	<u>Covariance[2,2]</u>	<u>CY_Y</u>	<u>Table 4-3</u>	<u>O</u>	
50	<u>Covariance[3,1]</u>	<u>CZ_X</u>	<u>Table 4-3</u>	<u>O</u>	
51	<u>Covariance[3,2]</u>	<u>CZ_Y</u>	<u>Table 4-3</u>	<u>O</u>	
52	<u>Covariance[3,3]</u>	<u>CZ_Z</u>	<u>Table 4-3</u>	<u>O</u>	
53	<u>Covariance[4,1]</u>	<u>CX_DOT_X</u>	<u>Table 4-3</u>	<u>O</u>	
54	<u>Covariance[4,2]</u>	<u>CX_DOT_Y</u>	<u>Table 4-3</u>	<u>O</u>	
55	<u>Covariance[4,3]</u>	<u>CX_DOT_Z</u>	<u>Table 4-3</u>	<u>O</u>	
56	<u>Covariance[4,4]</u>	<u>CX_DOT_X_DOT</u>	<u>Table 4-3</u>	<u>O</u>	
57	<u>Covariance[5,1]</u>	<u>CY_DOT_X</u>	<u>Table 4-3</u>	<u>O</u>	
58	<u>Covariance[5,2]</u>	<u>CY_DOT_Y</u>	<u>Table 4-3</u>	<u>O</u>	
59	<u>Covariance[5,3]</u>	<u>CY_DOT_Z</u>	<u>Table 4-3</u>	<u>O</u>	
60	<u>Covariance[5,4]</u>	<u>CY_DOT_X_DOT</u>	<u>Table 4-3</u>	<u>O</u>	
61	<u>Covariance[5,5]</u>	<u>CY_DOT_Y_DOT</u>	<u>Table 4-3</u>	<u>O</u>	
62	<u>Covariance[6,1]</u>	<u>CZ_DOT_X</u>	<u>Table 4-3</u>	<u>O</u>	
63	<u>Covariance[6,2]</u>	<u>CZ_DOT_Y</u>	<u>Table 4-3</u>	<u>O</u>	
64	<u>Covariance[6,3]</u>	<u>CZ_DOT_Z</u>	<u>Table 4-3</u>	<u>O</u>	
65	<u>Covariance[6,4]</u>	<u>CZ_DOT_X_DOT</u>	<u>Table 4-3</u>	<u>O</u>	
66	<u>Covariance[6,5]</u>	<u>CZ_DOT_Y_DOT</u>	<u>Table 4-3</u>	<u>O</u>	
67	<u>Covariance[6,6]</u>	<u>CZ_DOT_Z_DOT</u>	<u>Table 4-3</u>	<u>O</u>	
68	<u>User Defined Parameters logical block</u>	<u>N/A</u>	<u>Table 4-3</u>	<u>O</u>	

<p><u>69</u></p>	<p><u>As defined by user, "essential information that cannot be conveyed in COMMENT statements"</u></p>	<p><u>USER_DEFINED_x</u></p>	<p><u>Table 4-3</u></p>	<p><u>O</u></p>	
------------------	---	------------------------------	-------------------------	-----------------	--

A2.8 ORBIT EPHEMERIS MESSAGE REQUIREMENTS LIST

<u>Item</u>	<u>Feature</u>	<u>Keyword</u>	<u>Reference</u>	<u>Status M/O/C</u>	<u>Support</u>
<u>1</u>	<u>OEM Header</u>	<u>N/A</u>	<u>Table 5-2</u>	<u>M</u>	
<u>2</u>	<u>OEM Version</u>	<u>CCSDS_OEM_VERS</u>	<u>Table 5-2</u>	<u>M</u>	
<u>3</u>	<u>Comment</u>	<u>COMMENT</u>	<u>Table 5-2</u>	<u>O</u>	
<u>4</u>	<u>Message creation date and time</u>	<u>CREATION_DATE</u>	<u>Table 5-2</u>	<u>M</u>	
<u>5</u>	<u>Message originator</u>	<u>ORIGINATOR</u>	<u>Table 5-2</u>	<u>M</u>	
<u>6</u>	<u>Unique message identifier</u>	<u>MESSAGE_ID</u>	<u>Table 5-2</u>	<u>O</u>	
<u>7</u>	<u>Metadata logical block</u>	<u>N/A</u>	<u>Table 5-3</u>	<u>M</u>	
<u>8</u>	<u>Start of OEM Metadata</u>	<u>META_START</u>	<u>Table 5-3</u>	<u>M</u>	
<u>9</u>	<u>Comment</u>	<u>COMMENT</u>	<u>Table 5-3</u>	<u>O</u>	
<u>10</u>	<u>Name of space object</u>	<u>OBJECT_NAME</u>	<u>Table 5-3</u>	<u>M</u>	
<u>11</u>	<u>Identifier of space object</u>	<u>OBJECT_ID</u>	<u>Table 5-3</u>	<u>M</u>	
<u>12</u>	<u>Orbit center</u>	<u>CENTER_NAME</u>	<u>Table 5-3</u>	<u>M</u>	
<u>13</u>	<u>Reference frame</u>	<u>REF_FRAME</u>	<u>Table 5-3</u>	<u>M</u>	
<u>14</u>	<u>Epoch of reference frame</u>	<u>REF_FRAME_EPOCH</u>	<u>Table 5-3</u>	<u>O</u>	
<u>15</u>	<u>Time system applicable to data</u>	<u>TIME_SYSTEM</u>	<u>Table 5-3</u>	<u>M</u>	
<u>16</u>	<u>Start of TOTAL time span covered by data</u>	<u>START_TIME</u>	<u>Table 5-3</u>	<u>M</u>	
<u>17</u>	<u>Start of useable orbit data</u>	<u>USEABLE_START_TIME</u>	<u>Table 5-3</u>	<u>O</u>	
<u>18</u>	<u>End of useable orbit data</u>	<u>USEABLE_STOP_TIME</u>	<u>Table 5-3</u>	<u>O</u>	
<u>19</u>	<u>End of TOTAL time span covered by data</u>	<u>STOP_TIME</u>	<u>Table 5-3</u>	<u>M</u>	
<u>20</u>	<u>Recommended interpolation method</u>	<u>INTERPOLATION</u>	<u>Table 5-3</u>	<u>O</u>	
<u>21</u>	<u>Recommended interpolation degree</u>	<u>INTERPOLATION_DEGREE</u>	<u>Table 5-3</u>	<u>M</u>	
<u>22</u>	<u>End of OEM Metadata</u>	<u>META_STOP</u>	<u>Table 5-3</u>	<u>M</u>	
<u>23</u>	<u>Ephemeris lines</u>	<u>... <insert ephemeris data lines here.></u>	<u>Table 5-3</u>	<u>M</u>	
<u>24</u>	<u>Begin of OEM Covariance logical block</u>	<u>COV_START</u>	<u>Table 5-3</u>	<u>M</u>	
<u>25</u>	<u>Epoch of the navigation solution related to the covariance matrix</u>	<u>EPOCH</u>	<u>Table 5-3</u>	<u>M</u>	

<u>26</u>	<u>Reference frame of the covariance matrix, if different from that of the states in the ephemeris</u>	<u>COV_REF_FRAME</u>	<u>Table 5-3</u>	<u>M</u>	
<u>27</u>	<u>Covariance lines</u>	<u>... <insert covariance matrices here></u>	<u>Table 5-3</u>	<u>M</u>	
<u>28</u>	<u>End of OEM Covariance logical block</u>	<u>COV_STOP</u>	<u>Table 5-3</u>	<u>M</u>	

A2.9 ORBIT COMPREHENSIVE MESSAGE REQUIREMENTS LISTOCM Header

<u>Item</u>	<u>Feature</u>	<u>Keyword</u>	<u>Reference</u>	<u>Status M/O/C</u>	<u>Support</u>
<u>1</u>	<u>OCM Header</u>	<u>N/A</u>	<u>Table 6-2</u>	<u>M</u>	
<u>2</u>	<u>OCM Version</u>	<u>CCSDS_OCM_VERS</u>	<u>Table 6-2</u>	<u>M</u>	
<u>3</u>	<u>Comment</u>	<u>COMMENT</u>	<u>Table 6-2</u>	<u>O</u>	
<u>4</u>	<u>Message creation date and time</u>	<u>CREATION_DATE</u>	<u>Table 6-2</u>	<u>M</u>	
<u>5</u>	<u>Message originator</u>	<u>ORIGINATOR</u>	<u>Table 6-2</u>	<u>M</u>	
<u>6</u>	<u>Unique message identifier</u>	<u>MESSAGE_ID</u>	<u>Table 6-2</u>	<u>O</u>	

OCM Metadata

<u>Item</u>	<u>Feature</u>	<u>Keyword</u>	<u>Reference</u>	<u>Status M/O/C</u>	<u>Support</u>
<u>7</u>	<u>Metadata logical block</u>	<u>N/A</u>	<u>Table 6-3</u>	<u>M</u>	
<u>8</u>	<u>OCM Metadata Start</u>	<u>META_START</u>	<u>Table 6-3</u>	<u>M</u>	
<u>9</u>	<u>Comment</u>	<u>COMMENT</u>	<u>Table 6-3</u>	<u>O</u>	
<u>10</u>	<u>Message classification/caveats</u>	<u>CLASSIFICATION</u>	<u>Table 6-2</u>	<u>O</u>	
<u>11</u>	<u>Spacecraft name for the object</u>	<u>OBJECT_NAME</u>	<u>Table 6-3</u>	<u>O</u>	
<u>12</u>	<u>International designator for the object</u>	<u>INTERNATIONAL DESIGNATOR</u>	<u>Table 6-3</u>	<u>O</u>	
<u>13</u>	<u>Unique satellite identification designator</u>	<u>OBJECT DESIGNATOR</u>	<u>Table 6-3</u>	<u>O</u>	
<u>14</u>	<u>Message originator or programmatic Point-of-Contact</u>	<u>ORIGINATOR POC</u>	<u>Table 6-3</u>	<u>O</u>	
<u>15</u>	<u>Contact position of the originator PoC</u>	<u>ORIGINATOR_POSITION</u>	<u>Table 6-3</u>	<u>O</u>	
<u>16</u>	<u>Originator PoC phone number</u>	<u>ORIGINATOR_PHONE</u>	<u>Table 6-3</u>	<u>O</u>	
<u>17</u>	<u>Originator PoC address</u>	<u>ORIGINATOR_ADDRESS</u>	<u>Table 6-3</u>	<u>O</u>	
<u>18</u>	<u>Creating agency or operator</u>	<u>TECH_ORG</u>	<u>Table 6-3</u>	<u>O</u>	
<u>19</u>	<u>Technical Point-of-Contact</u>	<u>TECH_POC</u>	<u>Table 6-3</u>	<u>O</u>	
<u>20</u>	<u>Contact position of the technical PoC</u>	<u>TECH_POSITION</u>	<u>Table 6-3</u>	<u>O</u>	
<u>21</u>	<u>Technical PoC phone number</u>	<u>TECH_PHONE</u>	<u>Table 6-3</u>	<u>O</u>	
<u>22</u>	<u>Technical PoC address</u>	<u>TECH_ADDRESS</u>	<u>Table 6-3</u>	<u>O</u>	
<u>23</u>	<u>ID that uniquely identifies the previous message from this message originator for this particular space object</u>	<u>PREVIOUS_MESSAGE_ID</u>	<u>Table 6-3</u>	<u>O</u>	
<u>24</u>	<u>ID that uniquely identifies the next message from this message originator for this particular space object</u>	<u>NEXT_MESSAGE_ID</u>	<u>Table 6-3</u>	<u>O</u>	
<u>25</u>	<u>Unique identifier of linked Attitude Data Message(s)</u>	<u>ADM_MSG_LINK</u>	<u>Table 6-3</u>	<u>O</u>	

CCSDS PROPOSED STANDARD FOR ORBIT DATA MESSAGES

<u>26</u>	<u>Unique identifier of linked Conjunction Data Message(s)</u>	<u>CDM_MSG_LINK</u>	<u>Table 6-3</u>	<u>O</u>	
<u>27</u>	<u>Unique identifier of linked Pointing Request Message(s)</u>	<u>PRM_MSG_LINK</u>	<u>Table 6-3</u>	<u>O</u>	
<u>28</u>	<u>Unique identifier of linked Reentry Data Message(s)</u>	<u>RDM_MSG_LINK</u>	<u>Table 6-3</u>	<u>O</u>	
<u>30</u>	<u>Satellite catalog source</u>	<u>CATALOG_NAME</u>	<u>Table 6-3</u>	<u>O</u>	
<u>31</u>	<u>Satellite catalog source</u>	<u>ALTERNATE_NAMES</u>	<u>Table 6-3</u>	<u>O</u>	
<u>32</u>	<u>Operator of the space object</u>	<u>OPERATOR</u>	<u>Table 6-3</u>	<u>O</u>	
<u>33</u>	<u>Owner of the space object</u>	<u>OWNER</u>	<u>Table 6-3</u>	<u>O</u>	
<u>35</u>	<u>Country where the owner or responsible party is based</u>	<u>COUNTRY</u>	<u>Table 6-3</u>	<u>O</u>	
<u>36</u>	<u>Name of the constellation</u>	<u>CONSTELLATION</u>	<u>Table 6-3</u>	<u>O</u>	
<u>37</u>	<u>Type of object</u>	<u>OBJECT_TYPE</u>	<u>Table 6-3</u>	<u>O</u>	
<u>38</u>	<u>Operational status of the space object</u>	<u>OPS_STATUS</u>	<u>Table 6-3</u>	<u>O</u>	
<u>39</u>	<u>Type of orbit</u>	<u>ORBIT_CATEGORY</u>	<u>Table 6-3</u>	<u>O</u>	
<u>40</u>	<u>Elements of information included in this message</u>	<u>OCM_DATA_ELEMENTS</u>	<u>Table 6-3</u>	<u>O</u>	
<u>41</u>	<u>Time system of EPOCH_TZERO</u>	<u>TIME_SYSTEM</u>	<u>Table 6-3</u>	<u>O</u>	
<u>42</u>	<u>Default epoch to which all relative times are referenced</u>	<u>EPOCH_TZERO</u>	<u>Table 6-3</u>	<u>M</u>	
<u>43</u>	<u>Spacecraft clock epoch</u>	<u>SCLK_EPOCH</u>	<u>Table 6-3</u>	<u>O</u>	
<u>44</u>	<u>Spacecraft clock rate</u>	<u>SCLK_SEC_PER_SI_SEC</u>	<u>Table 6-3</u>	<u>O</u>	
<u>45</u>	<u>Creation epoch of the previous message from this originator for this particular space object</u>	<u>PREVIOUS_MESSAGE_EPOCH</u>	<u>Table 6-3</u>	<u>O</u>	
<u>46</u>	<u>Anticipated (or actual) epoch of the next message from this originator for this particular space object</u>	<u>NEXT_MESSAGE_EPOCH</u>	<u>Table 6-3</u>	<u>O</u>	
<u>47</u>	<u>Time of the earliest data</u>	<u>START_TIME</u>	<u>Table 6-3</u>	<u>O</u>	
<u>48</u>	<u>Time of the latest data</u>	<u>STOP_TIME</u>	<u>Table 6-3</u>	<u>O</u>	

CCSDS PROPOSED STANDARD FOR ORBIT DATA MESSAGES

<u>49</u>	<u>Span of time that the OCM covers, measured in days</u>	<u>TIME_SPAN</u>	<u>Table 6-3</u>	<u>O</u>	
<u>50</u>	<u>Difference (TAI – UTC) in seconds</u>	<u>TAIMUTC_AT_TZERO</u>	<u>Table 6-3</u>	<u>O</u>	
<u>51</u>	<u>Difference (UT1 – UTC) in seconds</u>	<u>UT1MUTC_AT_TZERO</u>	<u>Table 6-3</u>	<u>O</u>	
<u>52</u>	<u>Source and version of the message originator’s Earth Orientation Parameters (EOP)</u>	<u>EOP_SOURCE</u>	<u>Table 6-3</u>	<u>O</u>	
<u>53</u>	<u>Method used to select or interpolate sequential EOP data</u>	<u>INTERP_METHOD_EOP</u>	<u>Table 6-3</u>	<u>O</u>	
<u>54</u>	<u>Method used to select or interpolate sequential space weather data</u>	<u>INTERP_METHOD_SW</u>	<u>Table 6-3</u>	<u>O</u>	
<u>55</u>	<u>Source and version of the message originator’s celestial body (e.g., Sun/Earth/Planetary) ephemeris data</u>	<u>CELESTIAL_SOURCE</u>	<u>Table 6-3</u>	<u>O</u>	
<u>56</u>	<u>Metadata Stop</u>	<u>META_STOP</u>	<u>Table 6-3</u>	<u>M</u>	

OCM Data: Orbit State Time History

<u>Item</u>	<u>Feature</u>	<u>Keyword</u>	<u>Reference</u>	<u>Status M/O/C</u>	<u>Support</u>
	<u>Orbit state time history logical block</u>	<u>N/A</u>	<u>Table 6-4</u>	<u>O</u>	
	<u>Orbit state time history start</u>	<u>ORB_START</u>	<u>Table 6-4</u>	<u>M</u>	
	<u>Comment</u>	<u>COMMENT</u>	<u>Table 6-4</u>	<u>O</u>	
	<u>Identification number for this orbit state time history block</u>	<u>ORB_ID</u>	<u>Table 6-4</u>	<u>O</u>	
	<u>Identification number for the previous orbit time history</u>	<u>ORB_PREV_ID</u>	<u>Table 6-4</u>	<u>O</u>	
	<u>Identification number for the next orbit time history</u>	<u>ORB_NEXT_ID</u>	<u>Table 6-4</u>	<u>O</u>	
	<u>Basis of this Orbit State time history data</u>	<u>ORB_BASIS</u>	<u>Table 6-4</u>	<u>O</u>	
	<u>Identification number for the orbit determination, navigation solution, or simulation</u>	<u>ORB_BASIS_ID</u>	<u>Table 6-4</u>	<u>O</u>	
	<u>Recommended interpolation method</u>	<u>INTERPOLATION</u>	<u>Table 6-4</u>	<u>O</u>	
	<u>Recommended interpolation degree</u>	<u>INTERPOLATION_DEGREE</u>	<u>Table 6-4</u>	<u>O</u>	
	<u>Orbit averaging technique used</u>	<u>ORB_AVERAGING</u>	<u>Table 6-4</u>	<u>O</u>	
	<u>Origin of the orbit reference frame</u>	<u>CENTER_NAME</u>	<u>Table 6-4</u>	<u>O</u>	
	<u>Reference frame of the orbit state time history</u>	<u>ORB_REF_FRAME</u>	<u>Table 6-4</u>	<u>M</u>	
	<u>Epoch of the orbit data reference frame</u>	<u>ORB_FRAME_EPOCH</u>	<u>Table 6-4</u>	<u>O</u>	
	<u>Start of useable orbit data</u>	<u>USEABLE_START_TIME</u>	<u>Table 6-4</u>	<u>O</u>	
	<u>End of useable orbit data</u>	<u>USEABLE_STOP_TIME</u>	<u>Table 6-4</u>	<u>O</u>	
	<u>Orbit element set type</u>	<u>ORB_TYPE</u>	<u>Table 6-4</u>	<u>O</u>	
	<u>Orbital element units</u>	<u>ORB_UNITS</u>	<u>Table 6-4</u>	<u>M</u>	
	<u>OCM Orbit state time history</u>	<u>... <insert orbit state time history here></u>	<u>Table 6-4</u>	<u>M</u>	
	<u>Orbit state time history end</u>	<u>ORB_STOP</u>	<u>Table 6-4</u>	<u>M</u>	

OCM Data: Space Object Physical Characteristics

<u>Item</u>	<u>Feature</u>	<u>Keyword</u>	<u>Reference</u>	<u>Status M/O/C</u>	<u>Support</u>
	<u>Space Object Physical Characteristics logical block</u>	<u>N/A</u>	<u>Table 6-5</u>	<u>O</u>	
	<u>Start of a Space Object Physical Characteristics specification</u>	<u>PHYS_START</u>	<u>Table 6-5</u>	<u>M</u>	
	<u>Comment</u>	<u>COMMENT</u>	<u>Table 6-5</u>	<u>O</u>	
	<u>Satellite manufacturer name</u>	<u>MANUFACTURER</u>	<u>Table 6-5</u>	<u>O</u>	
	<u>Satellite manufacturer's spacecraft bus model name</u>	<u>BUS_MODEL</u>	<u>Table 6-5</u>	<u>O</u>	
	<u>Space objects that this object is docked to</u>	<u>DOCKED_WITH</u>	<u>Table 6-5</u>	<u>O</u>	
	<u>Additional drag Area facing the relative wind vector beyond that represented by AREA_ALONG_OEB <MAX, MED, MIN></u>	<u>DRAG_ADDL_AREA</u>	<u>Table 6-5</u>	<u>O</u>	
	<u>Drag coefficient</u>	<u>DRAG_COEFF_NOM</u>	<u>Table 6-5</u>	<u>O</u>	
	<u>Drag coeff. 1σ uncertainty</u>	<u>DRAG_UNCERTAINTY</u>	<u>Table 6-5</u>	<u>O</u>	
	<u>Space object total mass at beginning of life</u>	<u>INITIAL_MASS</u>	<u>Table 6-5</u>	<u>O</u>	
	<u>Space object total mass</u>	<u>MASS</u>	<u>Table 6-5</u>	<u>O</u>	
	<u>Space object dry mass</u>	<u>DRY_MASS</u>	<u>Table 6-5</u>	<u>O</u>	
	<u>Parent reference frame which maps to the Optimally Enclosing Box (OEB) frame</u>	<u>OEB_PARENT_FRAME</u>	<u>Table 6-5</u>	<u>O</u>	
	<u>Epoch of the OEB parent reference frame</u>	<u>OEB_PARENT_FRAME_EPOCH</u>	<u>Table 6-5</u>	<u>O</u>	
	<u>Quaternion q₁</u>	<u>OEB_Q1</u>	<u>Table 6-5</u>	<u>O</u>	
	<u>Quaternion q₂</u>	<u>OEB_Q2</u>	<u>Table 6-5</u>	<u>O</u>	
	<u>Quaternion q₃</u>	<u>OEB_Q3</u>	<u>Table 6-5</u>	<u>O</u>	
	<u>Quaternion q_c</u>	<u>OEB_QC</u>	<u>Table 6-5</u>	<u>O</u>	
	<u>Maximum physical OEB dimension</u>	<u>OEB_MAX</u>	<u>Table 6-5</u>	<u>O</u>	
	<u>Medium physical OEB dimension</u>	<u>OEB_INT</u>	<u>Table 6-5</u>	<u>O</u>	
	<u>Minimum physical dimension</u>	<u>OEB_MIN</u>	<u>Table 6-5</u>	<u>O</u>	
	<u>Cross-sectional area viewed along max OEB dimension</u>	<u>AREA_ALONG_OEB_MAX</u>	<u>Table 6-5</u>	<u>O</u>	
	<u>Cross-sectional area viewed along intermediate OEB dimension</u>	<u>AREA_ALONG_OEB_INT</u>	<u>Table 6-5</u>	<u>O</u>	
	<u>Cross-sectional area viewed along min OEB dimension</u>	<u>AREA_ALONG_OEB_MIN</u>	<u>Table 6-5</u>	<u>O</u>	
	<u>Minimum cross-sectional area for collision probability</u>	<u>AREA_MIN_FOR_PC</u>	<u>Table 6-5</u>	<u>O</u>	
	<u>Maximum cross-sectional area for collision probability</u>	<u>AREA_MAX_FOR_PC</u>	<u>Table 6-5</u>	<u>O</u>	

CCSDS PROPOSED STANDARD FOR ORBIT DATA MESSAGES

<u>Item</u>	<u>Feature</u>	<u>Keyword</u>	<u>Reference</u>	<u>Status</u> <u>M/O/C</u>	<u>Support</u>
	<u>Typical cross-sectional area for collision probability</u>	<u>AREA_TYP_FOR_PC</u>	<u>Table 6-5</u>	<u>Q</u>	
	<u>Typical (50th percentile) effective Radar Cross Section</u>	<u>RCS</u>	<u>Table 6-5</u>	<u>Q</u>	
	<u>Minimum Radar Cross Section</u>	<u>RCS_MIN</u>	<u>Table 6-5</u>	<u>Q</u>	
	<u>Maximum Radar Cross Section</u>	<u>RCS_MAX</u>	<u>Table 6-5</u>	<u>Q</u>	
	<u>SRP additional area</u>	<u>SRP_ADDL_AREA</u>	<u>Table 6-5</u>	<u>Q</u>	
	<u>Solar Radiation Pressure Coefficient</u>	<u>SOLAR_RAD_NOM</u>	<u>Table 6-5</u>	<u>Q</u>	
	<u>Solar Radiation Pressure 1</u>	<u>SOLAR_RAD_UNCERTAINTY</u>	<u>Table 6-5</u>	<u>Q</u>	
	<u>Typical (50th percentile) absolute Visual Magnitude</u>	<u>VM_ABSOLUTE</u>	<u>Table 6-5</u>	<u>Q</u>	
	<u>Minimum apparent Visual Magnitude</u>	<u>VM_APPARENT_MIN</u>	<u>Table 6-5</u>	<u>Q</u>	
	<u>Typical (50th percentile) apparent Visual Magnitude</u>	<u>VM_APPARENT</u>	<u>Table 6-5</u>	<u>Q</u>	
	<u>Maximum apparent Visual Magnitude</u>	<u>VM_APPARENT_MAX</u>	<u>Table 6-5</u>	<u>Q</u>	
	<u>Typical (50th percentile) coefficient of reflectivity</u>	<u>REFLECTIVITY</u>	<u>Table 6-5</u>	<u>Q</u>	
	<u>Primary mode of attitude control</u>	<u>ATT_CONTROL_MODE</u>	<u>Table 6-5</u>	<u>Q</u>	
	<u>Type of actuator for attitude control</u>	<u>ATT_ACTUATOR_TYPE</u>	<u>Table 6-5</u>	<u>Q</u>	
	<u>Accuracy of attitude knowledge</u>	<u>ATT_KNOWLEDGE</u>	<u>Table 6-5</u>	<u>Q</u>	
	<u>Ability (e.g. deadband) to control attitude</u>	<u>ATT_CONTROL</u>	<u>Table 6-5</u>	<u>Q</u>	
	<u>Combined ability to both knowledge and control attitude</u>	<u>ATT_POINTING</u>	<u>Table 6-5</u>	<u>Q</u>	
	<u>Average maneuver frequency</u>	<u>AVG_MANEUVER_FREQ</u>	<u>Table 6-5</u>	<u>Q</u>	
	<u>Maximum composite thrust</u>	<u>MAX_THRUST</u>	<u>Table 6-5</u>	<u>Q</u>	
	<u>Total ΔV capability of the spacecraft at beginning of life</u>	<u>DV_BOL</u>	<u>Table 6-5</u>	<u>Q</u>	
	<u>Total ΔV remaining</u>	<u>DV_REMAINING</u>	<u>Table 6-5</u>	<u>Q</u>	
	<u>Moment of Inertia about the X-axis</u>	<u>IXX</u>	<u>Table 6-5</u>	<u>Q</u>	
	<u>Moment of Inertia about the Y-axis</u>	<u>IYY</u>	<u>Table 6-5</u>	<u>Q</u>	
	<u>Moment of Inertia about the Z-axis</u>	<u>IZZ</u>	<u>Table 6-5</u>	<u>Q</u>	
	<u>Inertia Cross Product of the X & Y axes</u>	<u>IXY</u>	<u>Table 6-5</u>	<u>Q</u>	
	<u>Inertia Cross Product of the X & Z axes</u>	<u>IXZ</u>	<u>Table 6-5</u>	<u>Q</u>	

CCSDS PROPOSED STANDARD FOR ORBIT DATA MESSAGES

<u>Item</u>	<u>Feature</u>	<u>Keyword</u>	<u>Reference</u>	<u>Status</u> <u>M/O/C</u>	<u>Support</u>
	<u>Inertia Cross Product of the Y & Z axes</u>	<u>IYZ</u>	<u>Table 6-5</u>	<u>O</u>	
	<u>End of the Space Object Physical Characteristics specification</u>	<u>PHYS_STOP</u>	<u>Table 6-5</u>	<u>M</u>	

OCM Data: Covariance Time History

<u>Item</u>	<u>Feature</u>	<u>Keyword</u>	<u>Reference</u>	<u>Status M/O/C</u>	<u>Support</u>
	<u>Covariance time history logical block</u>	<u>N/A</u>	<u>Table 6-6</u>	<u>O</u>	
	<u>OCM start of a covariance time history section</u>	<u>COV_START</u>	<u>Table 6-6</u>	<u>M</u>	
	<u>Comment</u>	<u>COMMENT</u>	<u>Table 6-6</u>	<u>O</u>	
	<u>Identification number for this covariance time history block</u>	<u>COV_ID</u>	<u>Table 6-6</u>	<u>O</u>	
	<u>Identification number for the previous covariance time history</u>	<u>COV_PREV_ID</u>	<u>Table 6-6</u>	<u>O</u>	
	<u>Identification number for the next covariance time history</u>	<u>COV_NEXT_ID</u>	<u>Table 6-6</u>	<u>O</u>	
	<u>Basis of this covariance time history</u>	<u>COV_BASIS</u>	<u>Table 6-6</u>	<u>O</u>	
	<u>Identification number for the orbit determination, navigation solution, or simulation</u>	<u>COV_BASIS_ID</u>	<u>Table 6-6</u>	<u>O</u>	
	<u>Reference frame of the covariance time history</u>	<u>COV_REF_FRAME</u>	<u>Table 6-6</u>	<u>O</u>	
	<u>Epoch of the covariance data reference frame</u>	<u>COV_FRAME_EPOCH</u>	<u>Table 6-6</u>	<u>O</u>	
	<u>Minimum scale factor to apply to this covariance data</u>	<u>COV_SCALE_MIN</u>	<u>Table 6-6</u>	<u>O</u>	
	<u>Maximum scale factor to apply to this covariance data</u>	<u>COV_SCALE_MAX</u>	<u>Table 6-6</u>	<u>O</u>	
	<u>Confidence in the covariance errors matching reality</u>	<u>COV_CONFIDENCE</u>	<u>Table 6-6</u>	<u>O</u>	
	<u>Covariance composition</u>	<u>COV_TYPE</u>	<u>Table 6-6</u>	<u>O</u>	
	<u>Units of covariance data line standard deviations (i.e., the square root of the variances supplied in the covariance matrix diagonal elements)</u>	<u>COV_UNITS</u>	<u>Table 6-6</u>	<u>M</u>	

CCSDS PROPOSED STANDARD FOR ORBIT DATA MESSAGES

<u>Item</u>	<u>Feature</u>	<u>Keyword</u>	<u>Reference</u>	<u>Status</u> <u>M/O/C</u>	<u>Support</u>
	<u>Covariance data</u>	<u>... <Insert covariance data here></u>	<u>Table 6-6</u>	<u>M</u>	
	<u>End of a covariance time history section</u>	<u>COV_STOP</u>	<u>Table 6-6</u>	<u>M</u>	

OCM Data: Maneuver Specification

<u>Item</u>	<u>Feature</u>	<u>Keyword</u>	<u>Reference</u>	<u>Status M/O/C</u>	<u>Support</u>
	<u>Maneuver time history logical block</u>	<u>N/A</u>	<u>Table 6-7</u>	<u>O</u>	
	<u>Start of a maneuver data block</u>	<u>MAN_START</u>	<u>Table 6-7</u>	<u>M</u>	
	<u>Comment</u>	<u>COMMENT</u>	<u>Table 6-7</u>	<u>O</u>	
	<u>Identification number for this maneuver</u>	<u>MAN_ID</u>	<u>Table 6-7</u>	<u>O</u>	
	<u>Identification number for the previous maneuver</u>	<u>MAN_PREV_ID</u>	<u>Table 6-7</u>	<u>O</u>	
	<u>Identification number for the next maneuver</u>	<u>MAN_NEXT_ID</u>	<u>Table 6-7</u>	<u>O</u>	
	<u>Basis of this maneuver time history data</u>	<u>MAN_BASIS</u>	<u>Table 6-7</u>	<u>O</u>	
	<u>Identification number of the orbit determination</u>	<u>MAN_BASIS_ID</u>	<u>Table 6-7</u>	<u>O</u>	
	<u>Maneuver device identifier</u>	<u>MAN_DEVICE_ID</u>	<u>Table 6-7</u>	<u>M</u>	
	<u>Completion time of the previous maneuver</u>	<u>MAN_PREV_EPOCH</u>	<u>Table 6-7</u>	<u>O</u>	
	<u>Start time of the next maneuver</u>	<u>MAN_NEXT_EPOCH</u>	<u>Table 6-7</u>	<u>O</u>	
	<u>Specifies the purpose of the maneuver</u>	<u>MAN_PURPOSE</u>	<u>Table 6-7</u>	<u>O</u>	
	<u>Specifies the source of the orbit and/or attitude state(s)</u>	<u>MAN_PRED_SOURCE</u>	<u>Table 6-7</u>	<u>O</u>	
	<u>Reference frame in which the maneuver vector direction data is provided</u>	<u>MAN_REF_FRAME</u>	<u>Table 6-7</u>	<u>O</u>	
	<u>Epoch of the maneuver data reference frame</u>	<u>MAN_FRAME_EPOCH</u>	<u>Table 6-7</u>	<u>O</u>	
	<u>Origin of maneuver gravitational assist body</u>	<u>GRAV_ASSIST_NAME</u>	<u>Table 6-7</u>	<u>O</u>	
	<u>Duty cycle type to use for this maneuver time history</u>	<u>DC_TYPE</u>	<u>Table 6-7</u>	<u>O</u>	
	<u>Start time of the duty cycle-based maneuver window</u>	<u>DC_WIN_OPEN</u>	<u>Table 6-7</u>	<u>C</u>	

CCSDS PROPOSED STANDARD FOR ORBIT DATA MESSAGES

<u>Item</u>	<u>Feature</u>	<u>Keyword</u>	<u>Reference</u>	<u>Status M/O/C</u>	<u>Support</u>
	<u>End time of the duty cycle-based maneuver window</u>	<u>DC_WIN_CLOSE</u>	<u>Table 6-7</u>	<u>C</u>	
	<u>Minimum number of "ON" duty cycles</u>	<u>DC_MIN_CYCLES</u>	<u>Table 6-7</u>	<u>O</u>	
	<u>Maximum number of "ON" duty cycles</u>	<u>DC_MAX_CYCLES</u>	<u>Table 6-7</u>	<u>O</u>	
	<u>Start time of the initial duty cycle-based maneuver sequence</u>	<u>DC_EXEC_START</u>	<u>Table 6-7</u>	<u>C</u>	
	<u>End time of the final duty cycle-based maneuver sequence</u>	<u>DC_EXEC_STOP</u>	<u>Table 6-7</u>	<u>C</u>	
	<u>THRUST duty cycle reference time tag</u>	<u>DC_REF_TIME</u>	<u>Table 6-7</u>	<u>C</u>	
	<u>Thruster pulse "ON" duration</u>	<u>DC_TIME_PULSE_DURATION</u>	<u>Table 6-7</u>	<u>C</u>	
	<u>Elapsed time between the start of one pulse and the start of the next</u>	<u>DC_TIME_PULSE_PERIOD</u>	<u>Table 6-7</u>	<u>C</u>	
	<u>Specifies the "ON" reference unit vector direction</u>	<u>DC_REF_DIR</u>	<u>Table 6-7</u>	<u>C</u>	
	<u>Body frame reference unit vector "trigger" direction</u>	<u>DC_BODY_TRIGGER</u>	<u>Table 6-7</u>	<u>C</u>	
	<u>Phase angle offset of thruster pulse start</u>	<u>DC_PA_START_ANGLE</u>	<u>Table 6-7</u>	<u>C</u>	
	<u>Phase angle of thruster pulse stop</u>	<u>DC_PA_STOP_ANGLE</u>	<u>Table 6-7</u>	<u>C</u>	
	<u>Set of maneuver elements of information to follow the maneuver time tag</u>	<u>MAN_COMPOSITION</u>	<u>Table 6-7</u>	<u>M</u>	
	<u>Units of maneuver data line elements</u>	<u>MAN_UNITS</u>	<u>Table 6-7</u>	<u>M</u>	
	<u>Maneuver time history data</u>	<u>... < Insert maneuver data here ></u>	<u>Table 6-7</u>	<u>M</u>	
	<u>End maneuver data block</u>	<u>MAN_STOP</u>	<u>Table 6-7</u>	<u>M</u>	

OCM Data: Perturbations Specification

<u>Item</u>	<u>Feature</u>	<u>Keyword</u>	<u>Reference</u>	<u>Status M/O/C</u>	<u>Support</u>
	<u>Orbit perturbations parameters</u>	<u>N/A</u>	<u>Table 6-10</u>	<u>O</u>	
	<u>Start of the perturbations specification</u>	<u>PERT_START</u>	<u>Table 6-10</u>	<u>M</u>	
	<u>Comment</u>	<u>COMMENT</u>	<u>Table 6-10</u>	<u>O</u>	
	<u>Origin of the perturbing central bodies</u>	<u>CENTER_NAME</u>	<u>Table 6-10</u>	<u>O</u>	
	<u>Atmosphere model used in the simulation</u>	<u>ATMOSPHERIC_MODEL</u>	<u>Table 6-10</u>	<u>O</u>	
	<u>Gravity model used in the simulation</u>	<u>GRAVITY_MODEL</u>	<u>Table 6-10</u>	<u>O</u>	
	<u>Oblate spheroid equatorial radius</u>	<u>EQUATORIAL_RADIUS</u>	<u>Table 6-10</u>	<u>O</u>	
	<u>Gravitational coefficient of attracting body</u>	<u>GM</u>	<u>Table 6-10</u>	<u>O</u>	
	<u>“N-body” gravitational perturbations bodies used</u>	<u>N_BODY_PERTURBATIONS</u>	<u>Table 6-10</u>	<u>O</u>	
	<u>Central body angular rotation rate</u>	<u>CENTRAL_BODY_ROTATION</u>	<u>Table 6-10</u>	<u>O</u>	
	<u>Inverse of the central body’s oblate spheroid oblateness</u>	<u>OBLATE_FLATTENING</u>	<u>Table 6-10</u>	<u>O</u>	
	<u>Ocean tides model</u>	<u>OCEAN_TIDES_MODEL</u>	<u>Table 6-10</u>	<u>O</u>	
	<u>Solid tides model</u>	<u>SOLID_TIDES_MODEL</u>	<u>Table 6-10</u>	<u>O</u>	
	<u>Reduction theory used for precession and nutation modeling</u>	<u>REDUCTION_THEORY</u>	<u>Table 6-10</u>	<u>O</u>	
	<u>Albedo model</u>	<u>ALBEDO_MODEL</u>	<u>Table 6-10</u>	<u>O</u>	
	<u>Number of grid points used in the albedo model</u>	<u>ALBEDO_GRID_SIZE</u>	<u>Table 6-10</u>	<u>O</u>	
	<u>Shadow model used for Solar Radiation Pressure</u>	<u>SHADOW_MODEL</u>	<u>Table 6-10</u>	<u>O</u>	
	<u>List of planetary bodies for which SRP shadowing is modeled</u>	<u>SHADOW_BODIES</u>	<u>Table 6-10</u>	<u>O</u>	
	<u>SRP model used</u>	<u>SRP_MODEL</u>	<u>Table 6-10</u>	<u>O</u>	

CCSDS PROPOSED STANDARD FOR ORBIT DATA MESSAGES

<u>Item</u>	<u>Feature</u>	<u>Keyword</u>	<u>Reference</u>	<u>Status M/O/C</u>	<u>Support</u>
	<u>Source and version of the Space Weather data used in the creation of this message</u>	<u>SW_DATA_SOURCE</u>	<u>Table 6-10</u>	<u>○</u>	
	<u>Epoch when the Space Weather data file was obtained.</u>	<u>SW_DATA_EPOCH</u>	<u>Table 6-10</u>	<u>○</u>	
	<u>Method used to select or interpolate any and all sequential space weather data</u>	<u>SW_INTERP_METHOD</u>	<u>Table 6-10</u>	<u>○</u>	
	<u>A fixed (time invariant) value of the planetary 3-hour-range geomagnetic index Kp</u>	<u>FIXED_GEOMAG_KP</u>	<u>Table 6-10</u>	<u>○</u>	
	<u>A fixed (time invariant) value of the 3-hourly (equivalent range) geomagnetic index Ap</u>	<u>FIXED_GEOMAG_AP</u>	<u>Table 6-10</u>	<u>○</u>	
	<u>A fixed (time invariant) value of the planetary 1-hour-range geomagnetic index Dst</u>	<u>FIXED_GEOMAG_DST</u>	<u>Table 6-10</u>	<u>○</u>	
	<u>A fixed (time invariant) value of the solar flux daily proxy F10.7</u>	<u>FIXED_F10P7</u>	<u>Table 6-10</u>	<u>○</u>	
	<u>A fixed (time invariant) value of the solar flux 81-day running center-averaged proxy F10.7</u>	<u>FIXED_F10P7_MEAN</u>	<u>Table 6-10</u>	<u>○</u>	
	<u>A fixed (time invariant) value of the solar flux daily proxy M10.7</u>	<u>FIXED_M10P7</u>	<u>Table 6-10</u>	<u>○</u>	
	<u>A fixed (time invariant) value of the solar flux 81-day running center-averaged proxy M10.7</u>	<u>FIXED_M10P7_MEAN</u>	<u>Table 6-10</u>	<u>○</u>	
	<u>A fixed (time invariant) value of the solar flux daily proxy S10.7</u>	<u>FIXED_S10P7</u>	<u>Table 6-10</u>	<u>○</u>	

CCSDS PROPOSED STANDARD FOR ORBIT DATA MESSAGES

<u>Item</u>	<u>Feature</u>	<u>Keyword</u>	<u>Reference</u>	<u>Status M/O/C</u>	<u>Support</u>
	<u>A fixed (time invariant) value of the solar flux 81-day running center-averaged proxy S10.7</u>	<u>FIXED_S10P7_MEAN</u>	<u>Table 6-10</u>	<u>O</u>	
	<u>A fixed (time invariant) value of the solar flux daily proxy Y10.7</u>	<u>FIXED_Y10P7</u>	<u>Table 6-10</u>	<u>O</u>	
	<u>A fixed (time invariant) value of the solar flux 81-day running center-averaged proxy Y10.7</u>	<u>FIXED_Y10P7_MEAN</u>	<u>Table 6-10</u>	<u>O</u>	
	<u>Perturbations Data Block Start</u>	<u>PERT_STOP</u>	<u>Table 6-10</u>	<u>M</u>	

OCM Data: Orbit Determination Data

<u>Item</u>	<u>Feature</u>	<u>Keyword</u>	<u>Reference</u>	<u>Status M/O/C</u>	<u>Support</u>
	<u>Orbit determination parameters logical block</u>	<u>N/A</u>	<u>Table 6-11</u>	<u>O</u>	
	<u>Start of an orbit determination data section</u>	<u>OD_START</u>	<u>Table 6-11</u>	<u>M</u>	
	<u>Comment</u>	<u>COMMENT</u>	<u>Table 6-11</u>	<u>O</u>	
	<u>Identification number for this orbit determination</u>	<u>OD_ID</u>	<u>Table 6-11</u>	<u>M</u>	
	<u>Identification number for the previous orbit determination</u>	<u>OD_PREV_ID</u>	<u>Table 6-11</u>	<u>O</u>	
	<u>Type of orbit determination method used</u>	<u>OD_METHOD</u>	<u>Table 6-11</u>	<u>O</u>	
	<u>UTC epoch of the orbit determination solved-for state</u>	<u>OD_EPOCH</u>	<u>Table 6-11</u>	<u>O</u>	
	<u>Days elapsed between first accepted observation and OD_EPOCH</u>	<u>DAYS SINCE FIRST OBS</u>	<u>Table 6-11</u>	<u>O</u>	
	<u>Days elapsed between last accepted observation and OD_EPOCH</u>	<u>DAYS SINCE LAST OBS</u>	<u>Table 6-11</u>	<u>O</u>	
	<u>Number of days of observations recommended for the OD</u>	<u>RECOMMENDED_OD_SPAN</u>	<u>Table 6-11</u>	<u>O</u>	
	<u>Actual time span in days used for the OD</u>	<u>ACTUAL_OD_SPAN</u>	<u>Table 6-11</u>	<u>O</u>	
	<u>Number of observations available within the actual OD time span</u>	<u>OBS_AVAILABLE</u>	<u>Table 6-11</u>	<u>O</u>	
	<u>Number of observations accepted within the actual OD time span</u>	<u>OBS_USED</u>	<u>Table 6-11</u>	<u>O</u>	
	<u>Number of sensor tracks available for the OD within the actual time span</u>	<u>TRACKS_AVAILABLE</u>	<u>Table 6-11</u>	<u>O</u>	
	<u>Number of sensor tracks accepted for</u>	<u>TRACKS_USED</u>	<u>Table 6-11</u>	<u>O</u>	

CCSDS PROPOSED STANDARD FOR ORBIT DATA MESSAGES

<u>Item</u>	<u>Feature</u>	<u>Keyword</u>	<u>Reference</u>	<u>Status M/O/C</u>	<u>Support</u>
	<u>the OD within the actual time span</u>				
	<u>Maximum time between observations in the OD</u>	<u>MAXIMUM_OBS_GAP</u>	<u>Table 6-11</u>	<u>O</u>	
	<u>Positional error ellipsoid 1σ major eigenvalue at OD</u>	<u>OD_EPOCH_EIGMAJ</u>	<u>Table 6-11</u>	<u>O</u>	
	<u>Positional error ellipsoid 1σ intermediate eigenvalue at OD</u>	<u>OD_EPOCH_EIGMED</u>	<u>Table 6-11</u>	<u>O</u>	
	<u>Positional error ellipsoid 1σ minor eigenvalue at OD</u>	<u>OD_EPOCH_EIGMIN</u>	<u>Table 6-11</u>	<u>O</u>	
	<u>Max positional error ellipsoid 1σ major eigenvalue</u>	<u>OD_MAX_PRED_EIGMAJ</u>	<u>Table 6-11</u>	<u>O</u>	
	<u>Min positional error ellipsoid 1σ minor eigenvalue</u>	<u>OD_MIN_PRED_EIGMIN</u>	<u>Table 6-11</u>	<u>O</u>	
	<u>OD confidence metric, which by definition spans 0 to 100%</u>	<u>OD_CONFIDENCE</u>	<u>Table 6-11</u>	<u>O</u>	
	<u>Generalized Dilution of Precision for this orbit determination</u>	<u>GDOP</u>	<u>Table 6-11</u>	<u>O</u>	
	<u>Number of solve-for states in the orbit determination</u>	<u>SOLVE_N</u>	<u>Table 6-11</u>	<u>O</u>	
	<u>State elements solved for in the orbit determination</u>	<u>SOLVE_STATES</u>	<u>Table 6-11</u>	<u>O</u>	
	<u>Number of consider parameters used in the orbit determination</u>	<u>CONSIDER_N</u>	<u>Table 6-11</u>	<u>O</u>	
	<u>Consider parameters used in the orbit determination</u>	<u>CONSIDER_PARAMS</u>	<u>Table 6-11</u>	<u>O</u>	
	<u>Number of sensors used in the orbit determination</u>	<u>SENSORS_N</u>	<u>Table 6-11</u>	<u>O</u>	
	<u>Sensors used in the orbit determination</u>	<u>SENSORS</u>	<u>Table 6-11</u>	<u>O</u>	
	<u>Weighted RMS residual ratio</u>	<u>WEIGHTED_RMS</u>	<u>Table 6-11</u>	<u>O</u>	
	<u>File name(s) and/or associated identification</u>	<u>TDM_MSG_LINK</u>	<u>Table 6-11</u>	<u>O</u>	

CCSDS PROPOSED STANDARD FOR ORBIT DATA MESSAGES

<u>Item</u>	<u>Feature</u>	<u>Keyword</u>	<u>Reference</u>	<u>Status M/O/C</u>	<u>Support</u>
	<u>number(s) of Tracking Data Message (TDM) [9] observations</u>				
	<u>Observation data types utilized in this orbit determination</u>	<u>DATA_TYPES</u>	<u>Table 6-11</u>	<u>O</u>	
	<u>End of an orbit determination data section</u>	<u>OD_STOP</u>	<u>Table 6-11</u>	<u>M</u>	

OCM Data: User-Defined Parameters

<u>Item</u>	<u>Feature</u>	<u>Keyword</u>	<u>Reference</u>	<u>Status M/O/C</u>	<u>Support</u>
	<u>User Defined Parameters logical block</u>	<u>N/A</u>	<u>Table 6-12</u>	<u>O</u>	
	<u>OCM User-Defined Parameters start</u>	<u>USER_START</u>	<u>Table 6-12</u>	<u>M</u>	
	<u>Comment</u>	<u>COMMENT</u>	<u>Table 6-12</u>	<u>O</u>	
	<u>As defined by user, "essential information that cannot be conveyed in COMMENT statements"</u>	<u>(User-defined keywords)</u>	<u>Table 6-12</u>	<u>O</u>	
	<u>OCM User-Defined Parameters end</u>	<u>USER_STOP</u>	<u>Table 6-12</u>	<u>M</u>	

ANNEX B

NORMATIVE VALUES AND REFERENCES FOR TIMING SYSTEM, REFERENCE FRAME, ORBITAL ELEMENT, AND COVARIANCE-RELATED KEYWORDS

(NORMATIVE)

~~The set of accepted values for Originators, Orbit Centers, time systems, reference frames, orbit-relative reference frames, spacecraft and attitude control reference frames, orbital elements and additional covariance element sets for all Orbit Data Messages (i.e., OPM, OMM, OEM and OCM) are discussed in this annex. These acceptable~~ The values in this annex represent the recommended values for selected keywords present in OPM, OMM, OEM or OCM message. For details and descriptions of the keyword interpretations, the reader is directed to ANNEX N, Reference [N-1] and [N-7]. The message creator should seek to confirm with the recipient(s) that their software can support the selected keyword value, particularly for more complex content such as reference frames, orbital elements and covariance definitions.

These recommended values are stored on the SANA Registry, globally accessible on the CCSDS SANA registry website located at:

https://sanaregistry.org/r/navigation_standard_normative_annexes

Note that the message creator or recipient may wish to automate processing of SANA registry normative content, which can be done by ingesting and processing of such content in electronic format. These formats can be accessed via the “Actions” link on each registry, e.g. for the Orbital Elements registry, a comma separated value (CSV) format can be exported at: https://www.sanaregistry.org/r/orbital_elements?export=csv and a (JSON) format at: https://www.sanaregistry.org/r/orbital_elements?export=json. Note that both the registry and these electronic data formats contain the specification of how many vector elements corresponding to each keyword value.

Exchange partners may submit additional (new) ~~keywords~~ keyword values for consideration of future inclusion into the SANA registry by submitting a detailed email request (mailto:info@sanaregistry.org) per ANNEX ~~L~~M, Section ~~L2~~M2. The CCSDS Area or Working Group responsible for the maintenance of the ODM at the time of the request is the approval authority. Until a suggested value is included in the SANA registry, exchange partners may define and use values that are not listed in the SANA registry ~~only~~ if mutually agreed and properly documented between message exchange partners.

B1 MESSAGE ORIGINATORS

The set of ~~acceptable~~ recommended values for the **ORIGINATOR** keyword is ~~provided~~ enumerated in the SANA Registry of Organizations, located at:

<https://sanaregistry.org/r/organizations> ~~normative reference [10].~~

B2 REFERENCE FRAME ~~CENTER~~CENTERS AND THIRD-BODY PERTURBATIONS

~~The~~A set of ~~acceptable~~allowed values for the reference frame center keywords (CENTER_NAME for OPM, OEM, OMM, and OCM, as well as N_BODY_PERTURBATIONS, ~~ORBIT_CENTER_NAME, MAN_CENTER_NAME, STM_CENTER_NAME~~ in the OCM) is ~~provided in normative reference [12].~~enumerated in the SANA Registry of Orbit Centers, located at:

https://sanaregistry.org/r/orbit_centers

Note that these values may also be useful to specify another platform (satellite, airframe, ground vehicle, etc.) as the reference frame origin to permit the specification of relative positional state time history data. In this case, message authors shall clearly communicate to recipients ~~by ICD (as noted above)~~ that the orbit center is not a gravitational center, that propagation of ephemeris vectors or extrapolation of ephemeris start/stop states is not advisable, and that interpolation of state time histories should not be accomplished using classical orbit propagation forces, e.g., gravitational constants, drag.

B3 TIME SYSTEMS

~~The~~A set of ~~acceptable~~allowed values for the TIME_SYSTEM keyword is ~~provided~~enumerated in ~~ANNEX B~~ ~~normative reference [13].~~

~~For further details and description~~the SANA Registry of time systems, see references [M-1] and [M-3].Time Systems, located at:

https://sanaregistry.org/r/time_systems

B4 NON-ORBIT-RELATIVE REFERENCE FRAMES

~~The~~A set of ~~acceptable~~allowed non-orbit-relative reference frame values for ~~keyword~~are provided~~keywords is enumerated~~ in ~~normative reference [14].~~the SANA Registry of Celestial Body Reference Frames, located at:

~~Additional~~https://sanaregistry.org/r/celestial_body_reference_frames

B5 ORBIT-RELATIVE REFERENCE FRAMES

In addition to the above reference frames, maneuver and covariance data may be ~~specified~~in~~selected from the list of allowed~~ orbit-relative reference frames using *_REF_FRAME keyword values ~~provided in normative reference [15].~~enumerated in the SANA Registry of Orbit-Relative Reference Frames, located at:

https://sanaregistry.org/r/orbit_relative_reference_frames

Note that two types of orbit-relative local reference frames exist: inertial and rotating. When transforming velocity terms between inertial and rotating frames, remember to properly incorporate the $(\bar{\omega} \times \bar{r})$ contribution.

B6 ADDITIONAL SPACECRAFT AND ATTITUDE REFERENCE FRAMES

An additional allowed set of spacecraft and attitude control reference ~~frames are acceptable as provided~~ frame values for * REF FRAME keywords is enumerated in ~~normative reference [16].~~ the SANA Registry of Spacecraft and Attitude Control Reference Frames, located at:

https://sanaregistry.org/r/spacecraft_body_reference_frames

Note that for many of these frames (particularly those that are spacecraft hardware-dependent), an ICD will likely be necessary to fully define and convey understanding of these frames.

B7 ORBITAL ELEMENTS

~~The~~ A set of ~~acceptable~~ allowed values for the **ORB_TYPE** keyword is ~~provided~~ enumerated in ~~normative reference [17].~~ the SANA Registry of Orbital Elements, located at:

https://sanaregistry.org/r/orbital_elements

Unique to the Orbit Comprehensive Message (OCM), orbit element states and/or time histories may be specified in ~~the following~~ multiple element ~~sets~~ set types.

Orbit elements shall be interpreted as osculating elements unless either explicitly specified via the ORB_AVERAGING keyword or ~~pre-coordinated~~ as mutually agreed between ~~the~~ message ~~originator and recipient~~ exchange partners to contain mean elements (e.g. singly- or doubly-averaged elements based upon Kozai, Brouwer, or other theories).

Inertial reference frames shall be specified when employing inertial element sets.

When employing non-inertial element sets, inertial reference frames shall not be specified.

B8 ADDITIONAL COVARIANCE REPRESENTATIONS

In addition to the above orbit element sets, ~~covariance data may be specified in certain augmented element sets provided in normative reference [18].~~ additional allowed values for the COV_TYPE keyword includes the element sets enumerated in the SANA Registry of Covariance Representations, located at:

https://sanaregistry.org/r/orbital_covariance_matrix_types

B9 ATMOSPHERE MODELS

The ~~A~~ set of ~~acceptable~~allowed values for the **ATMOSPHERIC_MODEL** keyword is ~~provided~~enumerated in ~~normative reference [19]~~the SANA Registry of Atmosphere Models, located at:

https://sanaregistry.org/r/atmosphere_models

B10 GRAVITY MODELS

The ~~A~~ set of ~~acceptable~~allowed values for the **GRAVITY_MODEL** keyword is ~~provided~~enumerated in ~~normative reference [20]~~the SANA Registry of Gravity Models, located at:

https://sanaregistry.org/r/gravity_models

B11 OBJECT TYPES

The ~~A~~ set of ~~acceptable~~allowed values for the **OBJECT_TYPE** keyword is ~~provided~~enumerated in ~~normative reference [21]~~the SANA Registry of Object Types, located at:

https://sanaregistry.org/r/object_types

B12 OPERATIONAL STATUS

The ~~A~~ set of ~~acceptable~~allowed values for the **OPS_STATUS** keyword is ~~provided~~enumerated in ~~normative reference [22]~~the SANA Registry of Operational Status of Space Object, located at:

https://sanaregistry.org/r/operational_status

B13 ORBIT AVERAGING TECHNIQUES

The ~~A~~ set of ~~acceptable~~allowed values for the **ORB_AVERAGING** keyword is ~~provided~~enumerated in ~~normative reference [23]~~the SANA Registry of Orbit Averaging Techniques, located at:

https://sanaregistry.org/r/orbit_averaging

B14 ORBIT TYPES

The ~~A~~ set of ~~acceptable~~allowed values for the **ORBIT_TYPECATEGORY** keyword is ~~provided~~enumerated in ~~normative reference [24]~~the SANA Registry of Orbit Types, located at:

https://sanaregistry.org/r/orbit_types

ANNEX C

TECHNICAL MATERIAL

(INFORMATIVE)

C1 SATELLITE PHYSICAL CHARACTERISTICS SPECIFICATION
(INFORMATIVE)

This section of the informative technical annex defines satellite dimensional and orientational parameters of the OCM's satellite physical characteristics specification.

To facilitate improved modeling of the physical space occupied by a space object, the space object's attitude/orientation, the probability of a hard body collision occurring, and drag and SRP acceleration forces, the OCM allows the specification of an “**Optimally-Encompassing Box**” (**OEB**). Note that the OEB describes the physical space occupied by the space object, which may or may not align with the inertia tensor for that object.

For a box-shaped satellite (e.g., a CubeSat) without appendages, the satellite and a corresponding OEB would be a one-to-one mapping.

For a satellite having solar arrays that extend from the spacecraft body structure, the OEB would extend from the main satellite body to encompass the deployed solar arrays as well.

The OEB shape is shown in Fig. C- 1 below. As illustrated, the OEB reference frame axes (depicted in **RED**) are defined by convention as follows:

- The OEB x-axis is along the **longest** dimension of the box (\hat{X}_{OEB_MAX}). This is sometimes referred to the “span” of the space object.
- The OEB y-axis is along the **intermediate** orthonormal dimension (\hat{Y}_{OEB_MED})
- The OEB z-axis is along the **shortest** orthonormal dimension (\hat{Z}_{OEB_MIN}).

The BOX shape can easily represent a cube by setting all orthonormal dimensions equal. In the event that the longest two or three orthonormal dimensions are equivalent, \hat{X}_{OEB_MAX} is defined as the direction along one of those longest dimensions and the next as \hat{Y}_{OEB_MED} .

In the event that the longest two or three principal axis dimensions of the box are equivalent, \hat{X}_{OEB_MAX} is defined as the direction along one of those longest principal dimensions and the next as \hat{Y}_{OEB_MED} .

The OEB z-axis is always ~~be~~ defined as: $\hat{Z}_{OEB_MIN} = \hat{X}_{OEB_MAX} \times \hat{Y}_{OEB_MED}$.

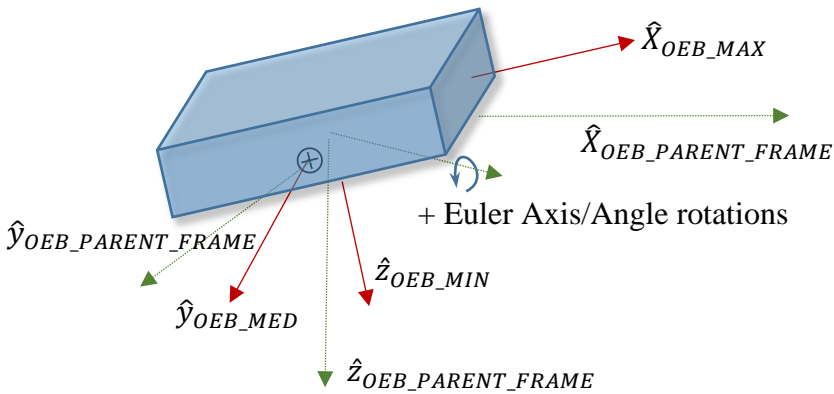

Fig. C- 1 Depiction of Optimally-Enclosing Box and definitions of MAX, MED, and MIN orientation vectors relative to OEB parent frame

NOTE: parent and body axis are shown in proximity to each other for display purposes only, but could generally be in any orientation as specified by the quaternion.

A fixed orientation of the Optimally-Encompassing Box with respect to the user-specified “OEB_PARENT_FRAME” is defined using an ordered sequence of Euler rotations that map from the user-specified OEB_PARENT_FRAME to the Optimally-Encompassing Box vector directions. The above figure shows the proper definitions and adopted sign conventions for Yaw, Pitch, and Roll angles. The resulting transformation sequence is:

$$\begin{bmatrix} x \\ y \\ z \end{bmatrix}_{OEB} = [M] \begin{bmatrix} x \\ y \\ z \end{bmatrix}_{OEB_PARENT_FRAME}$$

Where the frame transformation matrix [M] is a function of the quaternion components

$$[M] = \begin{bmatrix} q_1^2 - q_2^2 - q_3^2 + q_4^2 & 2(q_1q_2 + q_3q_4) & 2(q_1q_3 - q_2q_4) \\ 2(q_1q_2 - q_3q_4) & q_1^2 + q_2^2 - q_3^2 + q_4^2 & 2(q_2q_3 + q_1q_4) \\ 2(q_1q_3 + q_2q_4) & 2(q_2q_3 - q_1q_4) & -q_1^2 - q_2^2 + q_3^2 + q_4^2 \end{bmatrix} \begin{bmatrix} Q_1^2 - Q_2^2 - Q_3^2 + Q_4^2 \\ 2(Q_1Q_2 - Q_3Q_4) \\ 2(Q_1Q_3 + Q_2Q_4) \end{bmatrix}$$

The physical dimensions of the OEB (long, intermediate, and short dimensions) are specified via OEB_MAX, OEB_MEDINT, and OEB_MIN respectively.

The cross-sectional area as viewed along the OEB x, y and z axes (long, intermediate and short dimension directions) are specified via AREA_ALONG_OEB_MAX, AREA_ALONG_OEB_MEDINT, and AREA_ALONG_OEB_MIN, respectively. These projected areas can represent the actual cross-sectional area presented normal to each axis direction, which can be useful for drag, lift and SRP force estimates. The use of a blending function allows force estimations along total cross-sectional area observed when viewed from an arbitrary unit-vector direction: [x y z] is:

|

$$\underline{\text{DRAG AREA}} = \text{DRAG ADDL AREA} + \begin{bmatrix} \text{AREA_ALONG_OEB_MAX} \\ \text{AREA_ALONG_OEB_INT} \\ \text{AREA_ALONG_OEB_MIN} \end{bmatrix} \cdot [M] \begin{bmatrix} x \\ y \\ z \end{bmatrix}_{\text{OEB_PARENT_FRAME}}$$

C2 APPARENT-TO-ABSOLUTE VISUAL MAGNITUDE RELATIONSHIP (INFORMATIVE)

This section of the informative technical annex presents the relationships to be used to map apparent to absolute visual magnitude for inclusion in an OCM. These equations, based on ~~reference [M-8], ANNEX N, Reference [N-8]~~, examine signal magnitude for reflected illumination by a Resident Space Object (RSO) that is exoatmospheric, meaning that its illumination by the Sun is not reduced or impeded by atmospheric transmission losses. The equations do not account for spatial distribution across multiple detectors, which involves characterizing the Point Spread Function of the system.

~~The equation for VM_{target} is not provided.~~

Definitions:

- ~~$E_{\text{EntranceAperture}}$~~ A_{Target} Effective area of the target [m^2]
- $E_{\text{EntranceAperture}}$ Target's specific entrance aperture radiance [W/m^2]
- ~~I_{Sun}~~ Solar Intensity $\approx 3.088374161 \times 10^{25}$ [W]
- $d_{\text{SunToTarget}}$ Distance from the sun to the target (e.g. 1 AU = $1.4959787066 \times 10^{11}$ m)
- ~~$d_{\text{TargetToSensor}}$~~ Distance from target to sensor [m]
- dia_{Target} Effective diameter of the target, [m]
- E_{Sun} Exoatmospheric solar irradiance, nominally 1380 [W/m^2] at 1 AU
- ϕ Phase or Critical Angle to the Sun (CATS) from sun to the sensor, as shown in Fig. C-2 and measured at the observed target [rad]
- ~~$Phase(\phi)$~~ Geometric reflectance function [unitless, $0 < Phase(\phi) \leq 1$]
- F General shadowing term accounting for the penumbra region's influence [unitless, $0 < F \leq 1$, 0 = umbra and 1 = full Sun illumination]
- ~~A_{Target}~~ Effective area of the target [m^2]
- ~~π~~ Pi constant
- ~~ρ~~ Reflectance of the target [between 0 (none) and 1 (perfect reflectance)]
- ~~I_{Target}~~ Intensity of reflected energy from target treated as a point source [W]
- E_{Target} Target Irradiance at Sensor without atmospheric loss [W/m^2]
- ~~r_{Target}~~ Effective radius of the target [m^2] [DLO2]
- ~~$d_{\text{TargetToSensor}}$~~ Distance from target to sensor [m]
- ~~$\tau_{\text{atmosphere}}$~~ Atmospheric transmission [unitless, $0 < \tau \leq 1$]
- E_0 Ref. Visual Magnitude (Vega) Irradiance [$2.77894 \times 10^{-8} W/m^2$]
- F General shadowing term accounting for the penumbra region's influence [unitless, $0 < F \leq 1$, 0 = umbra, and 1 = full Sun illumination]
- ~~I_{Sun}~~ Solar Intensity $\approx 3.088374161 \times 10^{25}$ [W]
- ~~I_{Target}~~ Intensity of reflected energy from target treated as a point source [W]

$Phase(\varphi)$ Geometric reflectance function [unitless, $0 < Phase(\varphi) \leq 1$]
 φ Phase or Critical Angle to the Sun (CATS) from sun to the sensor, as shown in Fig. C- 2 and measured at the observed target [rad]
 π Pi constant
 ρ Reflectance of the target [between 0 (none) and 1 (perfect reflectance)]
 $\tau_{Atmosphere}$ Atmospheric transmission [unitless, $0 < \tau \leq 1$]

Given an optical sensor's measured target entrance aperture radiance:

$$E_{target} = \frac{E_{EntranceAperture}}{\tau_{Atmosphere}(\theta)} \text{ [W/m}^2\text{]}$$

$$VM_{apparent} = -2.5 \log_{10} \frac{E_{target}}{E_0}, \text{ measured on the visual magnitude scale}$$

~~$$E_{target} = \frac{E_{EntranceAperture}}{\tau_{Atmosphere}(\theta)} \text{ [W/m}^2\text{]}$$~~

or if $VM_{apparent}$ known: $E_{target} = E_0 10^{\left[-\frac{VM_{apparent}}{2.5}\right]}$

$$I_{target} = E_{target} d_{TargetToSensor}^2 \text{ [W]}$$

$$E_{Sun} = \frac{I_{Sun}}{d_{SunToTarget}^2} \text{ [W/m}^2\text{]}$$

$$Phase(\varphi) = \frac{\sin \varphi + (\pi - \varphi) \cos \varphi}{\pi}$$

~~$$\rho A_{Target} = \frac{\pi I_{Target}}{E_{Sun} F Phase(\varphi)} \text{ [m}^2\text{]}$$~~

~~$$A_{Target} = \frac{\pi I_{Target}}{\rho F E_{Sun} Phase(\varphi)} \text{ [m}^2\text{]} \text{ \{NOTE1: undefined in umbra (F=0=darkness), or no reflection (\rho = 0). NOTE2: If reflectance is unknown, one can assume a standard reference reflectance of fifteen percent\}}$$~~

From which an effective diameter of the physical object can be roughly approximated as:

$$dia_{Target} \approx \sqrt{\frac{4 A_{Target}}{\pi}}$$

From the above equations, $VM_{absolute}$ “normalized” to a 1 AU Sun-to-target distance, a phase angle of 0° and an example reference 40,000 km target-to-sensor distance (equivalent to a GEO satellite tracked at 15.6° elevation above the optical site's local horizon), is obtained as:

$$VM_{absolute} = -2.5 \log_{10} \left(\frac{[E_{Sun1AU}=1380 \text{ W/m}^2][Phase(0 \text{ rad})=1.0][\rho A_{Target} \text{ from above, in m}^2]}{\pi [E_0=2.77894 \times 10^{-8} \text{ W/m}^2][1.6 \times 10^{15} \text{ m}^2]} \right)$$

$\log_{10} \left\{ \frac{E_{target}}{E_0} \right\}$, from which:

$$VM_{absolute} \equiv -2.5 \log_{10} \left(\frac{[E_{Sun1AU}=1380 \text{ W/m}^2][Phase(0 \text{ rad})=1.0][\rho A_{Target} \text{ from above, in m}^2]}{\pi [E_0=2.77894 \times 10^{-8} \text{ W/m}^2][(40,000,000^2) \text{ m}^2]} \right)$$

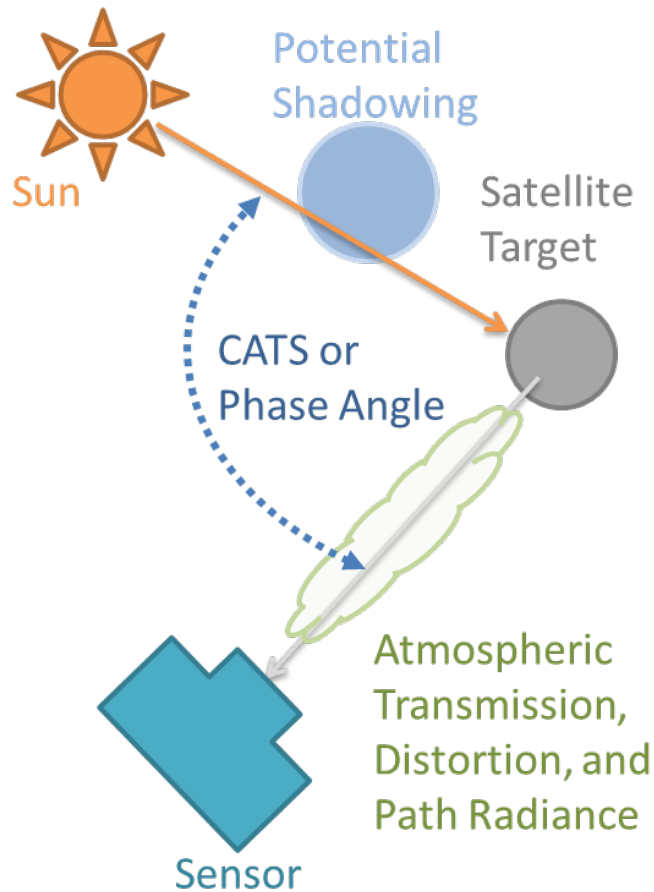

Fig. C- 2 Depiction of optical viewing Critical Angle *Foto* the Sun (CATS) phase angle geometry

C3 MANEUVER AND DUTY CYCLE DIAGRAMS (INFORMATIVE)

This section of the informative technical annex defines time-based, and phase-angle-based and ~~cone-based~~ duty cycle parameters.

A “duty cycle” is a cycle of thruster operation which operates intermittently rather than continuously, having an “on” interval followed by an “off” interval.

Time-based duty cycle parameters

Time-based duty cycle parameters define a window of duty cycle operations, the actual execution interval and “ON” and “OFF” intervals, as shown in Fig. C- 3.

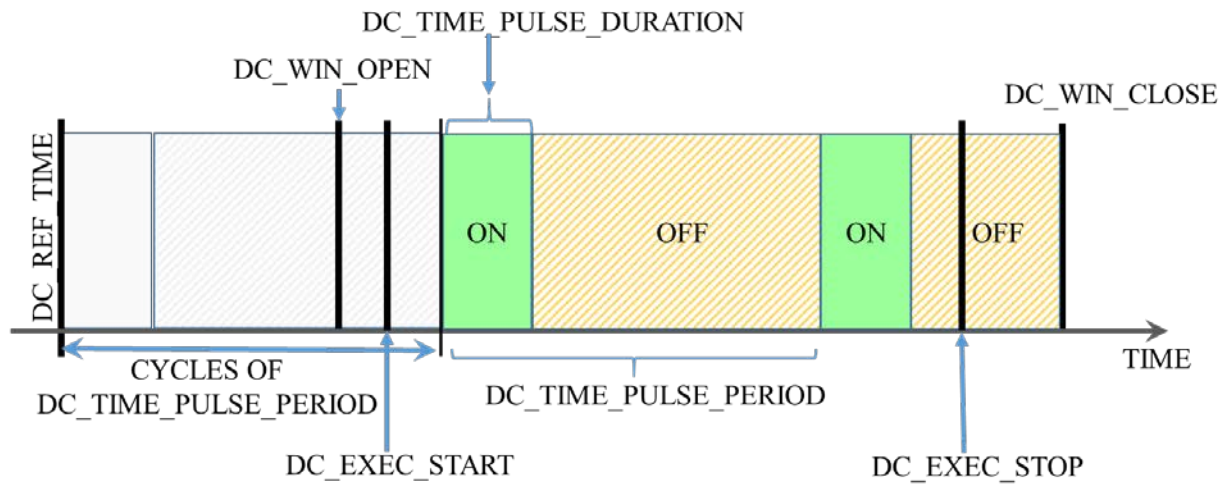

Fig. C- 3 Diagram of time-based duty cycle (*DUTY_CYCLE*DC_TYPE = “TIME”)

Angle-based duty cycle parameters

Angle-based duty cycle parameters also define a window of duty cycle operations and actual execution interval and “ON” and “OFF” intervals, but in this case the “ON” and “OFF” intervals are triggered by angular limits as shown in Fig. C- 4.

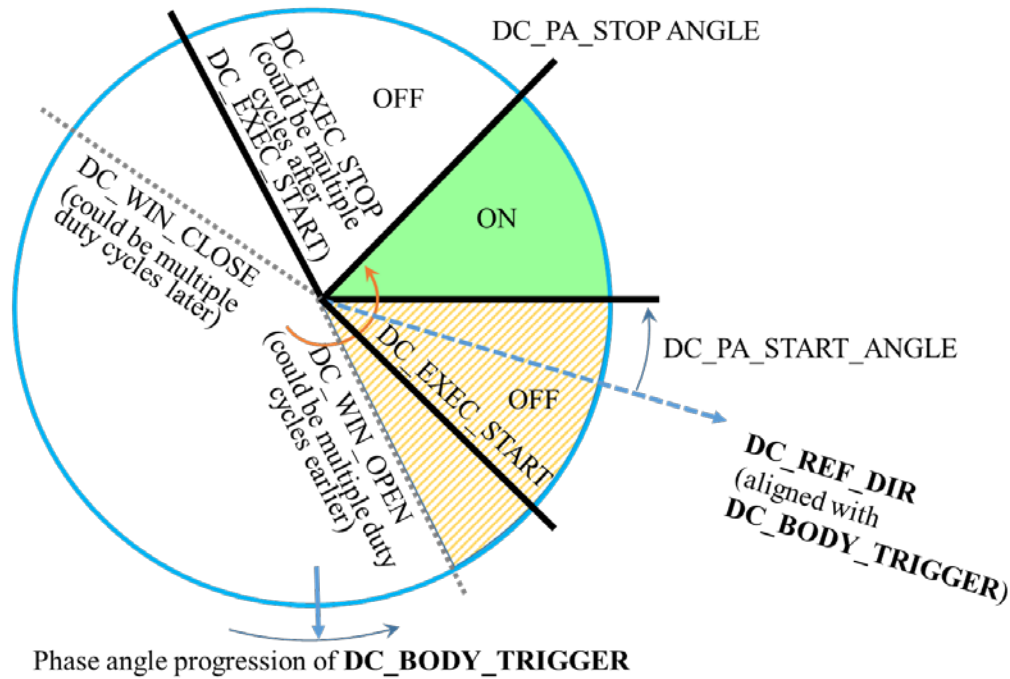

Fig. C-4 Diagram of a rotating spacecraft body's progression through an inertial clock angle-based duty cycle (DUTY_CYCLE_DC_TYPE = "PHASETIME AND ANGLE")

C4 ORBIT DETERMINATION GENERALIZED DILUTION OF PRECISION (GDoP) FORMULATION (INFORMATIVE)

This section of the informative technical annex defines the generalized dilution of precision (GDoP) formulation used in the orbit determination section of the OCM.

As described in reference [\[M-11\], ANNEX N, Reference \[N-14\]](#), Generalized Dilution of Precision (DoP) (GDoP) provides a method to assess the navigation performance over a time-integrated orbit solution. Generalized DoP broadens the DoP concept from the more common instantaneous geometric or kinematic solution of multiple transmit sources at one time, to a scenario associated with a receiver that is able to integrate metric range and/or Doppler (or range-rate) measurements over time, potentially from different transmit sources, to estimate the user's orbital position and velocity state. It is defined as a function of the sum of information matrices to obtain an observability grammian associated with a set of metric tracking measurements collected over a period of time.

The following equation for GDoP represents the uncertainty of an orbit state estimate as observed over time.

$$GDOP = \sqrt{\max \left[eig \left(\left(\sum_{t_0}^{t_n} \tilde{H}_0^T W \tilde{H}_0 \right)^{-1} \right) \right]}$$

Where H represents the measurement matrix modeled in the state estimate, and W is a diagonal matrix of relative weights that represents the accuracy of the measurements. $\tilde{H}_0^T W \tilde{H}_0$ represents the information matrix, the inverse of which is the covariance matrix. By summing over time, one obtains an estimate of the state uncertainty from the time-derived measurement set.

|

C5 EULER AXIS/ANGLE INTERPOLATION (INFORMATIVE)

The Euler Axis and Angle representation of Euler's Theorem (see ANNEX N, Reference [N-15, pp. 10-14]) is an effective way to interpolate a series of covariance matrices, reference frames or maneuver, thrust, or acceleration vector directions.

Interpolation of a series of three-dimensional vectors:

As presented in [N-15], and consistent with the nomenclature of [N-1] where e_1 , e_2 , and e_3 represent the three vector components of axis of rotation \hat{e} and φ represents the angle of rotation, a time-based interpolation of adjacent unit vectors \hat{v}_A and \hat{v}_B in a reference frame can be undertaken as:

- (1) The axis of rotation \hat{e} can be obtained as: $\hat{e} = \frac{\hat{v}_B \times \hat{v}_A}{|\hat{v}_B \times \hat{v}_A|}$
- (2) Assuming a constant rotational rate during this interval, $\varphi(t) = \frac{(t-t_1) \cos^{-1}(\hat{v}_A \cdot \hat{v}_B)}{(t_2-t_1)}$
- (3) The orthonormal rotation matrix $[M(t)]$ is then

$$= \begin{pmatrix} (1 - \cos \varphi) \hat{e}_x^2 + \cos \varphi & (1 - \cos \varphi) \hat{e}_x \hat{e}_y + \hat{e}_z \sin \varphi & (1 - \cos \varphi) \hat{e}_x \hat{e}_z - \hat{e}_y \sin \varphi \\ (1 - \cos \varphi) \hat{e}_y \hat{e}_x - \hat{e}_z \sin \varphi & (1 - \cos \varphi) \hat{e}_y^2 + \cos \varphi & (1 - \cos \varphi) \hat{e}_y \hat{e}_z + \hat{e}_x \sin \varphi \\ (1 - \cos \varphi) \hat{e}_z \hat{e}_x + \hat{e}_y \sin \varphi & (1 - \cos \varphi) \hat{e}_z \hat{e}_y - \hat{e}_x \sin \varphi & (1 - \cos \varphi) \hat{e}_z^2 + \cos \varphi \end{pmatrix}$$

- (4) From which the interpolated vector at time t is then $\hat{v}(t) = [M(t)]\hat{v}_A$
- (5) The accompanying vector magnitudes (e.g. eigenvalues or thrust or acceleration magnitudes) may be interpolated using Lagrange polynomials or linear expressions.

Interpolation of a series of reference (or covariance eigenvector) frames:

The eigenvector matrix $[E(t)]$ contains the row-wise storage of the major, intermediate and minor eigenvectors at time t, taking care to ensure that this ordered "triad" of vectors adheres to the righthand rule. When interpolating between two eigenvector matrices $[E_1]$ and $[E_2]$ derived from two adjacent covariance matrices respectively, $[E(t)]$ can be evaluated as:

- (6) The rotation occurring between $[E_1]$ and $[E_2]$ is: $[M_{BA}] \equiv [E_2][E_1]^T$
- (7) Compute $\sigma = (M_{BA11} + M_{BA22} + M_{BA33})$
- (8) The angle of rotation from A to B is: $\varphi_{BA} = \cos^{-1} \left[\frac{1}{2}(\sigma - 1) \right]$
- (9) Exercising caution to accommodate nonunique cases (when $\sin \varphi = 0$) as described in [N-15], the axis of rotation $\hat{e} = \left[\frac{(M_{BA23} - M_{BA32})}{2 \sin \varphi} \quad \frac{(M_{BA31} - M_{BA13})}{2 \sin \varphi} \quad \frac{(M_{BA12} - M_{BA21})}{2 \sin \varphi} \right]$
- (10) The angle of rotation at time t is $\varphi(t) = \frac{(t-t_1)\varphi_{BA}}{(t_2-t_1)}$
- (11) $[M(t)]$ can be computed using the above expression in step (3)
- (12) And finally, the eigenvector matrix $[E(t)] = [M(t)][E_1]$
- (13) When interpolating a series of covariance matrices, the accompanying eigenvalues may be interpolated using Lagrange polynomials or linear expressions.

ANNEX D

OPM EXAMPLES

(INFORMATIVE)

The following are examples of Orbit Parameter Messages (OPMs).

OPM examples in KVN:

The following figures are examples of OPMs in Keyword Value Notation (KVN) format. The first has only a state; the second has state, Keplerian elements, and maneuvers; the third and fourth include the position/velocity covariance matrix.

~~Fig. D-3 and Fig. D-4 include unique features of ODM version 2.0, and thus 'CCSDS_OPM_VERS = 2.0' (at a minimum) must be specified.~~

```

CCSDS_OPM_VERS = 3.0
CREATION_DATE  = 1998-11-06T09:23:57
ORIGINATOR     = JAXA

COMMENT        GEOCENTRIC, CARTESIAN, EARTH FIXED
OBJECT_NAME    = OSPREY 5
OBJECT_ID      = 1998-999A
CENTER_NAME    = EARTH
REF_FRAME      = ITRF2000
TIME_SYSTEM    = UTC

EPOCH =          1998-12-18T14:28:15.1172
X =             6503.514000
Y =             1239.647000
Z =             -717.490000
X_DOT =          -0.873160
Y_DOT =           8.740420
Z_DOT =          -4.191076
MASS =           3000.000000
SOLAR_RAD_AREA =  18.770000
SOLAR_RAD_COEFF =  1.000000
DRAG_AREA =      18.770000
DRAG_COEFF =      2.500000

```

Fig. D-1: Simple OPM file example

CCSDS PROPOSED STANDARD FOR ORBIT DATA MESSAGES

```

CCSDS_OPM_VERS      = 3.0

COMMENT  Generated by GSOC, R. Kiehling
COMMENT  Current intermediate orbit IO2 and maneuver planning data

CREATION_DATE      = 2000-06-03T05:33:00.000
ORIGINATOR         = GSOC

OBJECT_NAME        = EUTELSAT W4
OBJECT_ID          = 2000-028A
CENTER_NAME        = EARTH
REF_FRAME          = TOD
TIME_SYSTEM        = UTC

COMMENT  State Vector
EPOCH              = 2006-06-03T00:00:00.000
X                  = 6655.9942           [km]
Y                  = -40218.5751        [km]
Z                  = -82.9177           [km]
X_DOT              = 3.11548208         [km/s]
Y_DOT              = 0.47042605         [km/s]
Z_DOT              = -0.00101495        [km/s]

COMMENT  Keplerian elements
SEMI_MAJOR_AXIS    = 41399.5123         [km]
ECCENTRICITY       = 0.020842611
INCLINATION        = 0.117746           [deg]
RA_OF_ASC_NODE     = 17.604721          [deg]
ARG_OF_PERICENTER  = 218.242943         [deg]
TRUE_ANOMALY       = 41.922339         [deg]
GM                 = 398600.4415        [km**3/s**2]

COMMENT  Spacecraft parameters
MASS               = 1913.000           [kg]
SOLAR_RAD_AREA     = 10.000             [m**2]
SOLAR_RAD_COEFF    = 1.300
DRAG_AREA          = 10.000             [m**2]
DRAG_COEFF         = 2.300

COMMENT  2 planned maneuvers

COMMENT  First maneuver: AMF-3
COMMENT  Non-impulsive, thrust direction fixed in inertial frame
MAN_EPOCH_IGNITION = 2000-06-03T09:00:34.1
MAN_DURATION       = 132.60             [s]
MAN_DELTA_MASS     = -18.418            [kg]
MAN_REF_FRAME      = J2000
MAN_DV_1           = -0.02325700        [km/s]
MAN_DV_2           = 0.01683160         [km/s]
MAN_DV_3           = -0.00893444        [km/s]

COMMENT  Second maneuver: first station acquisition maneuver
COMMENT  impulsive, thrust direction fixed in RTN frame
MAN_EPOCH_IGNITION = 2000-06-05T18:59:21.0
MAN_DURATION       = 0.00               [s]
MAN_DELTA_MASS     = -1.469             [kg]
MAN_REF_FRAME      = RTN
MAN_DV_1           = 0.00101500         [km/s]
MAN_DV_2           = -0.00187300        [km/s]
MAN_DV_3           = 0.00000000         [km/s]

```

Fig. D-2: OPM file example with optional Keplerian elements and two maneuvers

```

CCSDS_OPM_VERS = 3.0

CREATION_DATE = 1998-11-06T09:23:57
ORIGINATOR    = JAXA
MESSAGE_ID    = OPM 201113719185

COMMENT       GEOCENTRIC, CARTESIAN, EARTH FIXED
OBJECT_NAME   = OSPREY 5
OBJECT_ID     = 1998-999A
CENTER_NAME   = EARTH
REF_FRAME     = ITRF1997
TIME_SYSTEM   = UTC

EPOCH =          1998-12-18T14:28:15.1172
X =              6503.514000
Y =              1239.647000
Z =              -717.490000
X_DOT =          -0.873160
Y_DOT =           8.740420
Z_DOT =          -4.191076

MASS =           3000.000000
SOLAR_RAD_AREA = 18.770000
SOLAR_RAD_COEFF = 1.000000
DRAG_AREA =      18.770000
DRAG_COEFF =     2.500000

CX_X = 3.331349476038534e-04
CY_X = 4.618927349220216e-04
CY_Y = 6.782421679971363e-04
CZ_X = -3.070007847730449e-04
CZ_Y = -4.221234189514228e-04
CZ_Z = 3.231931992380369e-04
CX_DOT_X = -3.349365033922630e-07
CX_DOT_Y = -4.686084221046758e-07
CX_DOT_Z = 2.484949578400095e-07
CX_DOT_X_DOT = 4.296022805587290e-10
CY_DOT_X = -2.211832501084875e-07
CY_DOT_Y = -2.864186892102733e-07
CY_DOT_Z = 1.798098699846038e-07
CY_DOT_X_DOT = 2.608899201686016e-10
CY_DOT_Y_DOT = 1.767514756338532e-10
CZ_DOT_X = -3.041346050686871e-07
CZ_DOT_Y = -4.989496988610662e-07
CZ_DOT_Z = 3.540310904497689e-07
CZ_DOT_X_DOT = 1.869263192954590e-10
CZ_DOT_Y_DOT = 1.008862586240695e-10
CZ_DOT_Z_DOT = 6.224444338635500e-10
    
```

Fig. D-3: OPM file example with covariance matrix

```

CCSDS_OPM_VERS      = 3.0
COMMENT  Generated by GSOC, R. Kiehling
COMMENT  Current intermediate orbit IO2 and maneuver planning data
CREATION_DATE       = 2000-06-03T05:33:00.000
ORIGINATOR          = GSOC
OBJECT_NAME         = EUTELSAT W4
OBJECT_ID           = 2000-028A
CENTER_NAME         = EARTH
REF_FRAME           = TOD
TIME_SYSTEM         = UTC
COMMENT  State Vector
EPOCH               = 2006-06-03T00:00:00.000
X                   = 6655.9942           [km]
Y                   = -40218.5751        [km]
Z                   = -82.9177           [km]
X_DOT               = 3.11548208         [km/s]
Y_DOT               = 0.47042605         [km/s]
Z_DOT               = -0.00101495        [km/s]
COMMENT  Keplerian elements
SEMI_MAJOR_AXIS     = 41399.5123         [km]
ECCENTRICITY        = 0.020842611
INCLINATION         = 0.117746           [deg]
RA_OF_ASC_NODE      = 17.604721         [deg]
ARG_OF_PERICENTER   = 218.242943        [deg]
TRUE_ANOMALY        = 41.922339         [deg]
GM                  = 398600.4415        [km**3/s**2]
COMMENT  Spacecraft parameters
MASS                = 1913.000           [kg]
SOLAR_RAD_AREA      = 10.000            [m**2]
SOLAR_RAD_COEFF     = 1.300
DRAG_AREA           = 10.000            [m**2]
DRAG_COEFF          = 2.300
COV_REF_FRAME       = RTN
CX_X = 3.331349476038534e-04           [km**2]
CY_X = 4.618927349220216e-04           [km**2]
CY_Y = 6.782421679971363e-04           [km**2]
CZ_X = -3.070007847730449e-04          [km**2]
CZ_Y = -4.221234189514228e-04          [km**2]
CZ_Z = 3.231931992380369e-04           [km**2]
CX_DOT_X = -3.349365033922630e-07       [km**2/s]
CX_DOT_Y = -4.686084221046758e-07       [km**2/s]
CX_DOT_Z = 2.484949578400095e-07        [km**2/s]
CX_DOT_X_DOT = 4.296022805587290e-10     [km**2/s**2]
CY_DOT_X = -2.211832501084875e-07        [km**2/s]
CY_DOT_Y = -2.864186892102733e-07        [km**2/s]
CY_DOT_Z = 1.798098699846038e-07         [km**2/s]
CY_DOT_X_DOT = 2.608899201686016e-10     [km**2/s**2]
CY_DOT_Y_DOT = 1.767514756338532e-10     [km**2/s**2]
CZ_DOT_X = -3.041346050686871e-07        [km**2/s]
CZ_DOT_Y = -4.989496988610662e-07        [km**2/s]
CZ_DOT_Z = 3.540310904497689e-07         [km**2/s]
CZ_DOT_X_DOT = 1.869263192954590e-10     [km**2/s**2]
CZ_DOT_Y_DOT = 1.008862586240695e-10     [km**2/s**2]
CZ_DOT_Z_DOT = 6.224444338635500e-10     [km**2/s**2]
USER_DEFINED_EARTH_MODEL = WGS-84

```

Fig. D-4: OPM file example with optional Keplerian elements, covariance matrix, and a user defined parameter

OPM example in XML:

Fig. D-5 contains an example of an OPM in Extensible Markup Language (XML) format.

```

<?xml version="1.0" encoding="UTF-8"?>
<opm xmlns:xsi="http://www.w3.org/2001/XMLSchema-instance"
  xsi:noNamespaceSchemaLocation="http://sanaregistry.org/r/ndmxml/ndmxml-1.0-master.xsd"
  id="CCSDS_OPM_VERS" version="3.0">
- <header>
- <COMMENT>THIS IS AN XML VERSION OF THE OPM</COMMENT>
- <CREATION_DATE>2001-11-06T09:23:57</CREATION_DATE>
- <ORIGINATOR>JAXA</ORIGINATOR>
- <MESSAGE_ID>OPM 201113719185</MESSAGE_ID>
</header>
- <body>
- <segment>
- <metadata>
- <COMMENT>GEOCENTRIC, CARTESIAN, EARTH FIXED</COMMENT>
- <OBJECT_NAME>OSPREY 5</OBJECT_NAME>
- <OBJECT_ID>1998-999A</OBJECT_ID>
- <CENTER_NAME>EARTH</CENTER_NAME>
- <REF_FRAME>ITRF1997</REF_FRAME>
- <TIME_SYSTEM>UTC</TIME_SYSTEM>
- </metadata>
- <data>
- <stateVector>
- <EPOCH>1996-12-18T14:28:15.1172</EPOCH>
- <X>6503.514000</X>
- <Y>1239.647000</Y>
- <Z>-717.490000</Z>
- <X_DOT>-0.873160</X_DOT>
- <Y_DOT>8.740420</Y_DOT>
- <Z_DOT>-4.191076</Z_DOT>
- </stateVector>
- <spacecraftParameters>
- <MASS>3000.000000</MASS>
- <SOLAR_RAD_AREA>18.770000</SOLAR_RAD_AREA>
- <SOLAR_RAD_COEFF>1.000000</SOLAR_RAD_COEFF>
- <DRAG_AREA>18.770000</DRAG_AREA>
- <DRAG_COEFF>2.500000</DRAG_COEFF>
- </spacecraftParameters>
- <covarianceMatrix>
- <COV_REF_FRAME>ITRF1997</COV_REF_FRAME>
- <CX_X>0.316</CX_X>
- <CY_X>0.722</CY_X>
- <CY_Y>0.518</CY_Y>
- <CZ_X>0.202</CZ_X>
- <CZ_Y>0.715</CZ_Y>
- <CZ_Z>0.002</CZ_Z>
- <CX_DOT_X>0.912</CX_DOT_X>
- <CX_DOT_Y>0.306</CX_DOT_Y>
- <CX_DOT_Z>0.276</CX_DOT_Z>
- <CX_DOT_X_DOT>0.797</CX_DOT_X_DOT>
- <CY_DOT_X>0.562</CY_DOT_X>
- <CY_DOT_Y>0.899</CY_DOT_Y>
- <CY_DOT_Z>0.022</CY_DOT_Z>
- <CY_DOT_X_DOT>0.079</CY_DOT_X_DOT>
- <CY_DOT_Y_DOT>0.415</CY_DOT_Y_DOT>
- <CZ_DOT_X>0.245</CZ_DOT_X>
- <CZ_DOT_Y>0.965</CZ_DOT_Y>
- <CZ_DOT_Z>0.950</CZ_DOT_Z>
- <CZ_DOT_X_DOT>0.435</CZ_DOT_X_DOT>
- <CZ_DOT_Y_DOT>0.621</CZ_DOT_Y_DOT>
- <CZ_DOT_Z_DOT>0.991</CZ_DOT_Z_DOT>
- </covarianceMatrix>
- </data>
- </segment>
- </body>
</opm>

```

Fig. D-5: OPM file example in XML format

ANNEX E

OMM EXAMPLES

(INFORMATIVE)

The following are examples of Orbit Mean-Element Messages (OMMs). All of these examples are based on the TLE shown in Fig. E-1.

```
GOES 9 [P]
1 23581U 95025A 07064.44075725 -.00000113 00000-0 10000-3 0 9250
2 23581 3.0539 81.7939 0005013 249.2363 150.1602 1.00273272 43169
```

Fig. E-1: Example Two Line Element Set (TLE)

OMM examples in KVN:

The following figures are examples of OMMs in Keyword Value Notation (KVN) format .

```
CCSDS_OMM_VERS = 3.0
CREATION_DATE = 2007-065T16:00:00
ORIGINATOR = NOAA
MESSAGE_ID = OMM 201113719185

OBJECT_NAME = GOES 9
OBJECT_ID = 1995-025A
CENTER_NAME = EARTH
REF_FRAME = TEMETEMEOFDATE
TIME_SYSTEM = UTC
MEAN_ELEMENT_THEORY = SGP/SGP4

EPOCH = 2007-064T10:34:41.4264
MEAN_MOTION = 1.00273272
ECCENTRICITY = 0.0005013
INCLINATION = 3.0539
RA_OF_ASC_NODE = 81.7939
ARG_OF_PERICENTER = 249.2363
MEAN_ANOMALY = 150.1602
GM = 398600.8
EPHEMERIS_TYPE = 0
CLASSIFICATION_TYPE = U
NORAD_CAT_ID = 23581
ELEMENT_SET_NO = 0925
REV_AT_EPOCH = 4316
BSTAR = 0.0001
MEAN_MOTION_DOT = -0.00000113
MEAN_MOTION_DDOT = 0.0
```

Fig. E-2: OMM file example without covariance matrix

```

CCSDS_OMM_VERS = 3.0
CREATION_DATE = 2007-065T16:00:00
ORIGINATOR = NOAA

OBJECT_NAME = GOES 9
OBJECT_ID = 1995-025A
CENTER_NAME = EARTH
REF_FRAME = TEMETEMEOFDATE
TIME_SYSTEM = UTC
MEAN_ELEMENT_THEORY = SGP/SGP4

EPOCH = 2007-064T10:34:41.4264
MEAN_MOTION = 1.00273272
ECCENTRICITY = 0.0005013
INCLINATION = 3.0539
RA_OF_ASC_NODE = 81.7939
ARG_OF_PERICENTER = 249.2363
MEAN_ANOMALY = 150.1602
GM = 398600.8

EPHEMERIS_TYPE = 0
CLASSIFICATION_TYPE = U
NORAD_CAT_ID = 23581
ELEMENT_SET_NO = 0925
REV_AT_EPOCH = 4316
BSTAR = 0.0001
MEAN_MOTION_DOT = -0.00000113
MEAN_MOTION_DDOT = 0.0

COV_REF_FRAME = TEMETEMEOFDATE
CX_X = 3.331349476038534e-04
CY_X = 4.618927349220216e-04
CY_Y = 6.782421679971363e-04
CZ_X = -3.070007847730449e-04
CZ_Y = -4.221234189514228e-04
CZ_Z = 3.231931992380369e-04
CX_DOT_X = -3.349365033922630e-07
CX_DOT_Y = -4.686084221046758e-07
CX_DOT_Z = 2.484949578400095e-07
CX_DOT_X_DOT = 4.296022805587290e-10
CY_DOT_X = -2.211832501084875e-07
CY_DOT_Y = -2.864186892102733e-07
CY_DOT_Z = 1.798098699846038e-07
CY_DOT_X_DOT = 2.608899201686016e-10
CY_DOT_Y_DOT = 1.767514756338532e-10
CZ_DOT_X = -3.041346050686871e-07
CZ_DOT_Y = -4.989496988610662e-07
CZ_DOT_Z = 3.540310904497689e-07
CZ_DOT_X_DOT = 1.869263192954590e-10
CZ_DOT_Y_DOT = 1.008862586240695e-10
CZ_DOT_Z_DOT = 6.224444338635500e-10
    
```

Fig. E-3: OMM file example with covariance matrix

```

CCSDS_OMM_VERS = 3.0
CREATION_DATE  = 2007-065T16:00:00
ORIGINATOR     = NOAA

OBJECT_NAME    = GOES 9
OBJECT_ID      = 1995-025A
CENTER_NAME    = EARTH
REF_FRAME      = TEMETEMEOFDATE
TIME_SYSTEM    = UTC
MEAN_ELEMENT_THEORY = SGP/SGP4

EPOCH          = 2007-064T10:34:41.4264
MEAN_MOTION    = 1.00273272      [rev/day]
ECCENTRICITY   = 0.0005013
INCLINATION    = 3.0539          [deg]
RA_OF_ASC_NODE = 81.7939        [deg]
ARG_OF_PERICENTER = 249.2363    [deg]
MEAN_ANOMALY  = 150.1602       [deg]
GM             = 398600.8        [km**3/s**2]
EPHEMERIS_TYPE = 0
CLASSIFICATION_TYPE = U
NORAD_CAT_ID   = 23581
ELEMENT_SET_NO = 0925
REV_AT_EPOCH   = 4316
BSTAR          = 0.0001         [1/ER]
MEAN_MOTION_DOT = -0.00000113  [rev/day**2]
MEAN_MOTION_DDOT = 0.0         [rev/day**3]

USER_DEFINED_EARTH_MODEL = WGS-84

```

Fig. E-4: OMM with units and a user defined parameter

OMM example in XML:

Fig. E-5 contains an example of an OMM in Extensible Markup Language (XML) format.

CCSDS PROPOSED STANDARD FOR ORBIT DATA MESSAGES

```

<?xml version="1.0" encoding="UTF-8"?>
<omm xmlns:xsi="http://www.w3.org/2001/XMLSchema-instance"
  xsi:noNamespaceSchemaLocation="http://sanaregistry.org/r/ndmxml/ndmxml-1.0-master.xsd"
  id="CCSDS_OMM_VERS" version="3.0">
- <header>
-   <COMMENT> THIS IS AN XML VERSION OF THE OMM </COMMENT>
-   <CREATION_DATE>2007-065T16:00:00</CREATION_DATE>
-   <ORIGINATOR>NOAA</ORIGINATOR>
-   <MESSAGE_ID>OMM 201113719185</MESSAGE_ID>
- </header>

- <body>
-   <segment>
-     <metadata>
-       <OBJECT_NAME>GOES-9</OBJECT_NAME>
-       <OBJECT_ID>1995-025A</OBJECT_ID>
-       <CENTER_NAME>EARTH</CENTER_NAME>
-       <REF_FRAME>FEMETEMEOFDATE</REF_FRAME>
-       <TIME_SYSTEM>UTC</TIME_SYSTEM>
-       <MEAN_ELEMENT_THEORY>TLE</MEAN_ELEMENT_THEORY>
-     </metadata>

-     <data>
-       <meanElements>
-         <EPOCH>2007-064T10:34:41.4264</EPOCH>
-         <MEAN_MOTION>1.00273272</MEAN_MOTION>
-         <ECCENTRICITY>0.0005013</ECCENTRICITY>
-         <INCLINATION>3.0539</INCLINATION>
-         <RA_OF_ASC_NODE>81.7939</RA_OF_ASC_NODE>
-         <ARG_OF_PERICENTER>249.2363</ARG_OF_PERICENTER>
-         <MEAN_ANOMALY>150.1602</MEAN_ANOMALY>
-         <GM>398600.8</GM>
-       </meanElements>
-       <tleParameters>
-         <NORAD_CAT_ID>23581</NORAD_CAT_ID>
-         <ELEMENT_SET_NO>0925</ELEMENT_SET_NO>
-         <REV_AT_EPOCH>4316</REV_AT_EPOCH>
-         <BSTAR>0.0001</BSTAR>
-         <MEAN_MOTION_DOT>-0.00000113</MEAN_MOTION_DOT>
-         <MEAN_MOTION_DDOT>0.0</MEAN_MOTION_DDOT>
-       </tleParameters>
-       <covarianceMatrix>
-         <COV_REF_FRAME>FEMETEMEOFDATE</COV_REF_FRAME>
-         <CX_X>3.331349476038534e-04</CX_X>
-         <CY_X>4.618927349220216e-04</CY_X>
-         <CY_Y>6.782421679971363e-04</CY_Y>
-         <CZ_X>-3.070007847730449e-04</CZ_X>
-         <CZ_Y>-4.221234189514228e-04</CZ_Y>
-         <CZ_Z>3.231931992380369e-04</CZ_Z>
-         <CX_DOT_X>-3.349365033922630e-07</CX_DOT_X>
-         <CX_DOT_Y>-4.686084221046758e-07</CX_DOT_Y>
-         <CX_DOT_Z>2.484949578400095e-07</CX_DOT_Z>
-         <CX_DOT_X_DOT>4.296022805587290e-10</CX_DOT_X_DOT>
-         <CY_DOT_X>-2.211832501084875e-07</CY_DOT_X>
-         <CY_DOT_Y>-2.864186892102733e-07</CY_DOT_Y>
-         <CY_DOT_Z>1.798098699846038e-07</CY_DOT_Z>
-         <CY_DOT_X_DOT>2.608899201686016e-10</CY_DOT_X_DOT>
-         <CY_DOT_Y_DOT>1.767514756338532e-10</CY_DOT_Y_DOT>
-         <CZ_DOT_X>-3.041346050686871e-07</CZ_DOT_X>
-         <CZ_DOT_Y>-4.989496988610662e-07</CZ_DOT_Y>
-         <CZ_DOT_Z>3.540310904497689e-07</CZ_DOT_Z>
-         <CZ_DOT_X_DOT>1.869263192954590e-10</CZ_DOT_X_DOT>
-         <CZ_DOT_Y_DOT>1.008862586240695e-10</CZ_DOT_Y_DOT>
-         <CZ_DOT_Z_DOT>6.224444338635500e-10</CZ_DOT_Z_DOT>
-       </covarianceMatrix>
-     </data>
-   </segment>
- </body>
</omm>

```

Fig. E-5: OMM file example in XML format

ANNEX F

OEM EXAMPLES

(INFORMATIVE)

The following are examples of Orbit Ephemeris Messages (OEMs).

OEM examples in KVN:

The following figures are examples of OEMs in Keyword Value Notation (KVN) format. Some ephemeris data lines have been omitted to save space.

```

CCSDS_OEM_VERS = 3.0
CREATION_DATE = 1996-11-04T17:22:31
ORIGINATOR = NASA/JPL

META_START
OBJECT_NAME      = MARS GLOBAL SURVEYOR
OBJECT_ID        = 1996-062A
CENTER_NAME      = MARS BARYCENTER
REF_FRAME        = J2000
TIME_SYSTEM      = UTC
START_TIME       = 1996-12-18T12:00:00.331
USEABLE_START_TIME = 1996-12-18T12:10:00.331
USEABLE_STOP_TIME  = 1996-12-28T21:23:00.331
STOP_TIME        = 1996-12-28T21:28:00.331
INTERPOLATION    = HERMITE
INTERPOLATION_DEGREE = 7
META_STOP

COMMENT This file was produced by M.R. Somebody, MCOOPigs, OSAR NAV/JPL, 1996NOV 04. It is
COMMENT to be used for DSN scheduling purposes only.

1996-12-18T12:00:00.331  2789.619 -280.045 -1746.755  4.73372 -2.49586 -1.04195
1996-12-18T12:01:00.331  2783.419 -308.143 -1877.071  5.18604 -2.42124 -1.99608
1996-12-18T12:02:00.331  2776.033 -336.859 -2008.682  5.63678 -2.33951 -1.94687

  < intervening data records omitted here >

1996-12-28T21:28:00.331 -3881.024 563.959 -682.773  -3.28827 -3.66735 1.63861

META_START
OBJECT_NAME      = MARS GLOBAL SURVEYOR
OBJECT_ID        = 1996-062A
CENTER_NAME      = MARS BARYCENTER
REF_FRAME        = J2000
TIME_SYSTEM      = UTC
START_TIME       = 1996-12-28T21:29:07.267
USEABLE_START_TIME = 1996-12-28T22:08:02.5
USEABLE_STOP_TIME  = 1996-12-30T01:18:02.5
STOP_TIME        = 1996-12-30T01:28:02.267
INTERPOLATION    = HERMITE
INTERPOLATION_DEGREE = 7
META_STOP

COMMENT This block begins after trajectory correction maneuver TCM-3.

1996-12-28T21:29:07.267 -2432.166 -063.042 1742.754  7.33702 -3.495867 -1.041945
1996-12-28T21:59:02.267 -2445.234 -878.141 1873.073  1.86043 -3.421256 -0.996366
1996-12-28T22:00:02.267 -2458.079 -683.858 2007.684  6.36786 -3.339563 -0.946654

  < intervening data records omitted here >

1996-12-30T01:28:02.267 2164.375 1115.811 -688.131  -3.53328 -2.88452 0.88535

```

Fig. F-1: OEM Example ~~With~~with No Acceleration, No Covariance

```

CCSDS_OEM_VERS = 3.0

COMMENT  OEM WITH OPTIONAL ACCELERATIONS

CREATION_DATE = 1996-11-04T17:22:31
ORIGINATOR = NASA/JPL

META_START
OBJECT_NAME      = MARS GLOBAL SURVEYOR
OBJECT_ID        = 2000-028A
CENTER_NAME      = MARS BARYCENTER
REF_FRAME        = J2000
TIME_SYSTEM      = UTC
START_TIME       = 1996-12-18T12:00:00.331
USEABLE_START_TIME = 1996-12-18T12:10:00.331
USEABLE_STOP_TIME  = 1996-12-28T21:23:00.331
STOP_TIME        = 1996-12-28T21:28:00.331
INTERPOLATION    = HERMITE
INTERPOLATION_DEGREE = 7
META_STOP

COMMENT  This file was produced by M.R. Somebody, MSOO NAV/JPL, 2000 NOV 04. It is
COMMENT  to be used for DSN scheduling purposes only.

1996-12-18T12:00:00.331  2789.6 -280.0 -1746.8  4.73 -2.50 -1.04  0.008 0.001 -0.159
1996-12-18T12:01:00.331  2783.4 -308.1 -1877.1  5.19 -2.42 -2.00  0.008 0.001  0.001
1996-12-18T12:02:00.331  2776.0 -336.9 -2008.7  5.64 -2.34 -1.95  0.008 0.001  0.159

    < intervening data records omitted here >

1996-12-28T21:28:00.331 -3881.0  564.0 -682.8 -3.29 -3.67  1.64  -0.003 0.000  0.000
    
```

Fig. F-2: OEM Example with Optional Accelerations

```

CCSDS_OEM_VERS = 3.0
CREATION_DATE = 1996-11-04T17:22:31
ORIGINATOR = NASA/JPL

MESSAGE_ID = OEM 201113719185
META_START
OBJECT_NAME      = MARS GLOBAL SURVEYOR
OBJECT_ID        = 1996-062A
CENTER_NAME      = MARS BARYCENTER
REF_FRAME        = J2000
TIME_SYSTEM      = UTC
START_TIME       = 1996-12-28T21:29:07.267
USEABLE_START_TIME = 1996-12-28T22:08:02.5
USEABLE_STOP_TIME  = 1996-12-30T01:18:02.5
STOP_TIME        = 1996-12-30T01:28:02.267
INTERPOLATION    = HERMITE
INTERPOLATION_DEGREE = 7
META_STOP

COMMENT- This block begins after trajectory correction maneuver TCM-3.

1996-12-28T21:29:07.267 -2432.166 -063.042 1742.754 7.33702 -3.495867 -1.041945
1996-12-28T21:59:02.267 -2445.234 -878.141 1873.073 1.86043 -3.421256 -0.996366
1996-12-28T22:00:02.267 -2458.079 -683.858 2007.684 6.36786 -3.339563 -0.946654

  < intervening data records omitted here >

1996-12-30T01:28:02.267 2164.375 1115.811 -688.131 -3.53328 -2.88452 0.88535

COVCOVARIANCE_START
EPOCH = 1996-12-28T21:29:07.267
COV_REF_FRAME = J2000
  3.3313494e-04
  4.6189273e-04  6.7824216e-04
-3.0700078e-04 -4.2212341e-04  3.2319319e-04
-3.3493650e-07 -4.6860842e-07  2.4849495e-07  4.2960228e-10
-2.2118325e-07 -2.8641868e-07  1.7980986e-07  2.6088992e-10  1.7675147e-10
-3.0413460e-07 -4.9894969e-07  3.5403109e-07  1.8692631e-10  1.0088625e-10  6.2244443e-10

EPOCH = 1996-12-29T21:00:00
COV_REF_FRAME = J2000
  3.4424505e-04
  4.5078162e-04  6.8935327e-04
-3.0600067e-04 -4.1101230e-04  3.3420420e-04
-3.2382549e-07 -4.5750731e-07  2.3738384e-07  4.3071339e-10
-2.1007214e-07 -2.7530757e-07  1.6870875e-07  2.5077881e-10  1.8786258e-10
-3.0302350e-07 -4.8783858e-07  3.4302008e-07  1.7581520e-10  1.0077514e-10  6.2244443e-10
COVARIANCE_STOP
    
```

Fig. F-3: OEM Example with Optional Covariance Matrices

OEM example in XML:

Fig. F-4 contains an example of an Orbit Ephemeris Message in Extensible Markup Language (XML) format.

```

<?xml version="1.0" encoding="UTF-8"?>
<oem xmlns:xsi="http://www.w3.org/2001/XMLSchema-instance"
     xsi:noNamespaceSchemaLocation="http://sanaregistry.org/r/ndmxml/ndmxml-1.0-master.xsd"
     id="CCSDS_OEM_VERS" version="3.0">
  - <header>
  -   <COMMENT>OEM WITH OPTIONAL ACCELERATIONS</COMMENT>
  -   <CREATION_DATE>1996-11-04T17:22:31</CREATION_DATE>
  -   <ORIGINATOR>NASA/JPL</ORIGINATOR>
  -   <MESSAGE_ID>OEM 201113719185</MESSAGE_ID>
    
```

CCSDS PROPOSED STANDARD FOR ORBIT DATA MESSAGES

```

</header>
- <body>
-   <segment>
-     <metadata>
-       <OBJECT_NAME>MARS GLOBAL SURVEYOR</OBJECT_NAME>
-       <OBJECT_ID>2000-028A</OBJECT_ID>
-       <CENTER_NAME>MARS BARYCENTER</CENTER_NAME>
-       <REF_FRAME>J2000</REF_FRAME>
-       <TIME_SYSTEM>UTC</TIME_SYSTEM>
-       <START_TIME>1996-12-18T12:00:00.331</START_TIME>
-       <USEABLE_START_TIME>1996-12-18T12:10:00.331</USEABLE_START_TIME>
-       <USEABLE_STOP_TIME>1996-12-28T21:23:00.331</USEABLE_STOP_TIME>
-       <STOP_TIME>1996-12-28T21:28:00.331</STOP_TIME>
-       <INTERPOLATION>HERMITE</INTERPOLATION>
-       <INTERPOLATION_DEGREE>7</INTERPOLATION_DEGREE>
-     </metadata>
-     <data>
-       <COMMENT>Produced by M.R. Sombedody, MSOO NAV/JPL, 1996 OCT 11. It is</COMMENT>
-       <COMMENT>to be used for DSN scheduling purposes only.</COMMENT>
-       <stateVector>
-         <EPOCH>1996-12-18T12:00:00.331</EPOCH>
-         <X>2789.6</X>
-         <Y>-280.0</Y>
-         <Z>-1746.8</Z>
-         <X_DOT>4.73</X_DOT>
-         <Y_DOT>-2.50</Y_DOT>
-         <Z_DOT>-1.04</Z_DOT>
-         <X_DDOT>0.008</X_DDOT>
-         <Y_DDOT>0.001</Y_DDOT>
-         <Z_DDOT>-0.159</Z_DDOT>
-       </stateVector>
-       <stateVector>
-         <EPOCH>1996-12-18T12:01:00.331</EPOCH>
-         <X>2783.4</X>
-         <Y>-308.1</Y>
-         <Z>-1877.1</Z>
-         <X_DOT>5.19</X_DOT>
-         <Y_DOT>-2.42</Y_DOT>
-         <Z_DOT>-2.00</Z_DOT>
-         <X_DDOT>0.008</X_DDOT>
-         <Y_DDOT>0.001</Y_DDOT>
-         <Z_DDOT>0.001</Z_DDOT>
-       </stateVector>
-       <stateVector>
-         <EPOCH>1996-12-18T12:02:00.331</EPOCH>
-         <X>2776.0</X>
-         <Y>-336.9</Y>
-         <Z>-2008.7</Z>
-         <X_DOT>5.64</X_DOT>
-         <Y_DOT>-2.34</Y_DOT>
-         <Z_DOT>-1.95</Z_DOT>
-         <X_DDOT>0.008</X_DDOT>
-         <Y_DDOT>0.001</Y_DDOT>
-         <Z_DDOT>0.159</Z_DDOT>
-       </stateVector>
-       <stateVector>
-         <EPOCH>1996-12-28T21:28:00.331</EPOCH>
-         <X>-3881.0</X>
-         <Y>564.0</Y>
-         <Z>-682.8</Z>
-         <X_DOT>-3.29</X_DOT>
-         <Y_DOT>-3.67</Y_DOT>
-         <Z_DOT>1.64</Z_DOT>
-         <X_DDOT>-0.003</X_DDOT>
-         <Y_DDOT>0.000</Y_DDOT>
-         <Z_DDOT>0.000</Z_DDOT>
-       </stateVector>
-       <covarianceMatrix>
-         <EPOCH></>1996-12-28T22:28:00.331</EPOCH>
-         <COV_REF_FRAME>ITRF1997</COV_REF_FRAME>
-         <CX_X>0.316</CX_X>

```



```

----- <CY_X>0.722</CY_X>
----- <CY_Y>0.518</CY_Y>
----- <CZ_X>0.202</CZ_X>
----- <CZ_Y>0.715</CZ_Y>
----- <CZ_Z>0.002</CZ_Z>
----- <CX_DOT_X>0.912</CX_DOT_X>
----- <CX_DOT_Y>0.306</CX_DOT_Y>
----- <CX_DOT_Z>0.276</CX_DOT_Z>
----- <CX_DOT_X_DOT>0.797</CX_DOT_X_DOT>
----- <CY_DOT_X>0.562</CY_DOT_X>
----- <CY_DOT_Y>0.899</CY_DOT_Y>
----- <CY_DOT_Z>0.022</CY_DOT_Z>
----- <CY_DOT_X_DOT>0.079</CY_DOT_X_DOT>
----- <CY_DOT_Y_DOT>0.415</CY_DOT_Y_DOT>
----- <CZ_DOT_X>0.245</CZ_DOT_X>
----- <CZ_DOT_Y>0.965</CZ_DOT_Y>
----- <CZ_DOT_Z>0.950</CZ_DOT_Z>
----- <CZ_DOT_X_DOT>0.435</CZ_DOT_X_DOT>
----- <CZ_DOT_Y_DOT>0.621</CZ_DOT_Y_DOT>
----- <CZ_DOT_Z_DOT>0.991</CZ_DOT_Z_DOT>
----- </covarianceMatrix>
----- </data>
----- </segment>
----- </body>
----- </oem>

```

Fig. F-4: OEM file example in XML format

ANNEX G

OCM EXAMPLES AND ASSOCIATED SUPPLEMENTARY
INFORMATION

(INFORMATIVE)

The following are examples of Orbit Comprehensive Messages (OCMs).

OCM examples in KVN:

The following figures are examples of OCMs in Keyword Value Notation (KVN) format. The first has only a time history of orbital states and constitutes a minimal content OCM. The second includes space object characteristics and perturbations specifications; the third includes a time series of maneuvers, a time history of Cartesian position and velocity orbit states, followed by a time history of Keplerian elements; and the fourth includes a time series of covariance matrices, ~~and the fifth contains a State Transition Matrix section.~~

```

CCSDS_OCM_VERS = 3.0
CREATION_DATE = 1998-11-06T09:23:57
ORIGINATOR = JAXA
META_START
TIME_SYSTEM = UTC
EPOCH_TZERO = 1998-12-18T14:28:15.1172
META_STOP
ORB_START
ORB_BASIS=SIMULATION
ORB_REF_FRAME=ITRF2000
ORB_UNITS= [ km, km, km, km/s, km/s, km/s ]
0.0 2789.6 -280.0 -1746.8 4.73 -2.50 -1.04
10.0 2783.4 -308.1 -1877.1 5.19 -2.42 -2.00
20.0 2776.0 -336.9 -2008.7 5.64 -2.34 -1.95
< intervening data records omitted here >
500.0 2164.375 1115.811 -688.131 -3.53328 -2.88452 0.88535
ORB_STOP

```

Fig. G-1: Simple/Succinct OCM File example with only Cartesian ephemeris. In this example, ~~the reference frame (ORB_REF_FRAME) defaults to ITRF2000,~~ CENTER_NAME defaults to EARTH and orbit type (ORB_TYPE) to CARTPV. In this example, at the expense of readability, KVN values are unaligned to minimize message storage and transmission size.

CCSDS PROPOSED STANDARD FOR ORBIT DATA MESSAGES

```

CCSDS_OCM_VERS = 3.0
COMMENT This OCM reflects the latest conditions post-maneuver A67Z
COMMENT This example shows the specification of multiple comment lines
CREATION_DATE = 1998-11-06T09:23:57
ORIGINATOR = JAXA
MESSAGE_ID = OCM 201113719185

META_START
OBJECT_NAME = OSPREY 5
INTERNATIONAL DESIGNATOR = 1998-999A

ORIGINATOR_POC = R. Rabbit
ORIGINATOR_POSITION = Flight Dynamics Mission Design Lead
ORIGINATOR_PHONE = (719)555-1234

META_START
TECH_POC = Mr. Rodgers
TECH_PHONE = (719)555-1234
TECH_ADDRESS = email@email.XXX

OBJECT_NAME = OSPREY 5
INTERNATIONAL DESIGNATOR = 1998-999A

TIME_SYSTEM = UT1
EPOCH_TZERO = 1998-12-18T00:00:00.0000
TIME_SYSTEM = UT1

TAIMUTC_AT_TZERO = 36 [s]
UT1MUTC_AT_TZERO = .357 [s]
META_STOP

ORB_START
COMMENT GEOCENTRIC, CARTESIAN, EARTH FIXED
COMMENT THIS IS MY SECOND COMMENT LINE
ORB_BASIS=PREDICTED
ORB_REF_FRAME = EFG
ORB_TYPE = CARTPVA
ORB_UNITS = [km, km, km, km/s, km/s, km/s]
1998-12-18T14:28:25.1172 2789.6 -280.0 -1746.8 4.73 -2.50 -1.04 0.008 0.001 -0.159
ORB_STOP

PHYS_START
COMMENT Spacecraft Physical Characteristics:
MASS = 100.0 [kg]
OEB_Q1 = 0.03123
OEB_Q2 = 0.78543
OEB_Q3 = 0.39158
OEB_QC = 0.47832
OEB_MAX = 2.0 [m]
OEB_MEDINT = 1.0 [m]
OEB_MIN = 0.5 [m]
AREA_ALONG_OEB_MAX = 0.15 [m**2]
AREA_ALONG_OEB_MEDINT = 0.3 [m**2]
AREA_ALONG_OEB_MIN = 0.5 [m**2]
PHYS_STOP

PERT_START
COMMENT Perturbations Specification:
ATMOSPHERIC_MODEL = NRLMSIS00
GRAVITY_MODEL = EGM-96: 36D 360
GM = 398600.4415 [km**3/s**2]
N_BODY_PERTURBATIONS = MOON, SUN
FIXED_GEOMAG_KP = 12.0
FIXED_F10P7 = 105.0
FIXED_F10P7_MEAN = 120.0
PERT_STOP

USER_START
EARTH_MODEL = WGS-84
USER_DEFINED_CONSOLE_POC = MAXWELL RAFERTY
USER_STOP

```



Fig. G-2: OCM example with space object characteristics and perturbations

CCSDS PROPOSED STANDARD FOR ORBIT DATA MESSAGES

```

CCSDS_OCM_VERS = 3.0
CREATION_DATE = 1998-11-06T09:23:57
ORIGINATOR = JAXA
META_START
EPOCH_TZERO = 1998-12-18T14:28:15.1172
META_STOP

ORB_START
COMMENT ORBIT EPHEMERIS INCORPORATING DEPLOYMENTS AND MANEUVERS (BELOW)
ORB_BASIS=PREDICTED
ORB_REF_FRAME = TOD
ORB_FRAME_EPOCH = 1998-12-18T14:28:15.1172
ORB_TYPE = CARTPVA
0.00000ORB_UNITS = [km,km,km,km/s,km/s,km/s,km/s**2,km/s**2,km/s**2]
1998-12-18T14:36:05.1172 2789.6 -280.0 -1746.8 4.73 -2.50 -1.04 0.008 0.001 -0.159
10.000001998-12-18T14:36:15.1172 2783.4 -308.1 -1877.1 5.19 -2.42 -2.00 0.008 0.001
0.001
20.000001998-12-18T14:36:25.1172 2776.0 -336.9 -2008.7 5.64 -2.34 -1.95 0.008 0.001
0.159
< intervening data records omitted here >
1998-12-18T14:36:35.1172 2164.3 1115.8 -688.1 -3.533 -2.884 0.885 0.008 0.001 0.159
ORB_STOP

PHYS_START
COMMENT Spacecraft Physical Characteristics:
DRAG_ADDL_AREA = 10.00 [m**2]
DRAG_COEFF_NOM = 2.300
DRAG_UNCERTAINTY = 5.0
MASS = 100200.0 [kg]
SOLAR_RADSSOLAR_ADDL_AREA = 4.00
SOLAR_RAD_COEFF = 1.300
PHYS_STOP

MAN_START
COMMENT = Ten 1kg objects deployed at 1 m/s from 200kg190kg host over 100 s
timespan time
COMMENT = 20 deg off of back-track direction
MAN_ID = E_W_20160305B
MAN_BASIS = PREDICTEDCANDIDATE
MAN_IS_ADDITIVE = YESDEVICE_ID = DEPLOY
MAN_PURPOSE = DEPLOY
MAN_BOI=DV_X, DV_Y, DV_Z, DV_SIGMA, DV_DMSS, DEPLOY_ID, DEPLOY_DV_X, DEPLOY_DV_Y, DEPLOY_DV_Z, DEPLOY_MASS
MAN_REF_FRAME = RTN
MAN_COMPOSITION = DEPLOY_ID, DEPLOY_DV_X, DEPLOY_DV_Y, DEPLOY_DV_Z, <cont.>
DEPLOY_MASS, DEPLOY_DV_SIGMA, DEPLOY_DV_RATIO, DEPLOY_DV_CDA
MAN_UNITS = [nd, m/s, m/s, m/s, kg, %, nd, cm**2/kg]
500.0 -0.00144 0.00470 -0.00092 0.0 -1.0 CUBESAT_10 0.28773 -0.93969 0.18491 -1.0
5.0 -0.005025 0.033
510.0 -0.00071 0.00470 -0.00156 0.0 -1.0 CUBESAT_11 0.14208 -0.93969 0.31111 -1.0
5.0 -0.005051 0.033
520.0 -0.00024 0.00470 -0.00169 0.0 -1.0 CUBESAT_12 -0.04867 -0.93969 0.33854 -1.0
5.0 -0.005076 0.033
530.0 -0.00112 0.00470 -0.00129 0.0 -1.0 CUBESAT_13 -0.22398 -0.93969 0.25848 -1.0
5.0 -0.005102 0.033
540.0 -0.00164 0.00470 -0.00048 0.0 -1.0 CUBESAT_14 -0.32817 -0.93969 0.09636 -1.0
5.0 -0.005128 0.033
550.0 -0.00164 0.00470 -0.00048 0.0 -1.0 CUBESAT_15 -0.32817 -0.93969 -0.09636 -1.0
5.0 -0.005154 0.033
560.0 -0.00112 0.00470 -0.00129 0.0 -1.0 CUBESAT_16 -0.22398 -0.93969 -0.25848 -1.0
5.0 -0.005181 0.033
570.0 -0.00024 0.00470 -0.00169 0.0 -1.0 CUBESAT_17 -0.04867 -0.93969 -0.33854 -1.0
5.0 -0.005208 0.033
580.0 -0.00071 0.00470 -0.00156 0.0 -1.0 CUBESAT_18 0.14208 -0.93969 -0.31111 -1.0
5.0 -0.005236 0.033
590.0 -0.00144 0.00470 -0.00092 0.0 -1.0 CUBESAT_19 0.28773 -0.93969 -0.18491 -1.0
5.0 -0.005263 0.033
MAN_STOP

MAN_START
COMMENT = 100 s of 0.5N +in-track thrust w/effic η=0.95, Isp=300s, 5% 1-sigma error

```

```

MAN_ID           = E_W_20160305B
MAN_BASIS       = PREDICTEDCANDIDATE
MAN_IS_ADDITIVE = YESDEVICE_ID = THR_01
MAN_PURPOSE     = ORBIT_ADJUST
MAN_EOI         = MAN_DURA, THR_X, THR_Y, THR_Z, THR_SIGMA, THR_INTERP, THR_ISP, THR_EFFIC
MAN_REF_FRAME   = RTN
MAN_COMPOSITION = MAN_DURA, THR_X, THR_Y, THR_Z, THR_SIGMA, THR_INTERP, THR_ISP, THR_EFFIC
MAN_UNITS       = [s, N, N, N, %, nd, s, nd]
1998-12-18T14:36:35.1172 100.0 0.0 0.5 0.0 5.0 NOON 300.0 0.95
MAN_STOP

PERT_START
COMMENT Perturbations specification
GM           = 398600.4415          [km**3/s**2]
PERT_STOP

OD_START
COMMENT Orbit Determination information
OD_ID       = OD #10059
OD_PREV_ID  = OD #10058
OD_EPOCH    = 2001-11-06T11:17:33
OBS_USED    = 273
TRACKS_USED = 91
OD_STOP
    
```

Fig. G-3: OCM example with deployed objects and low-level thrusting maneuver during deployment to make “string-of-pearls” deployment

NOTE 1: This example is aligned with a multi-deployment simulation for a future mission, thus the specific mission is not identified.

NOTE 2: The demarcation “<cont.>” indicates that this single line is shown, for display purposes only, in multiple lines. This demarcation shall not be used in the actual OCM message, as all specified content shall be provided on the same line as its matching time tag.

CCSDS PROPOSED STANDARD FOR ORBIT DATA MESSAGES

```

CCSDS_OCM_VERS = 3.0
CREATION_DATE = 1998-11-06T09:23:57
ORIGINATOR = JAXA

META_START
OBJECT_NAME = OSPREY 5
OBJECT_DESIGNATOR= 98765
INTERNATIONAL_DESIGNATOR = 1998-999A
CATALOG_NAME = CSPOC
OBJECT_DESIGNATOR = 98765

TIME_SYSTEM = UTC
EPOCH_TZERO = 1998-12-18T14:28:15.1172
TIME_SYSTEM = UTC
META_STOP

ORB_START
ORB_BASIS = PREDICTED
ORB_REF_FRAME = TOD
ORB_FRAME_EPOCH = 1998-12-18T14:28:15.1172
USEABLE_START_TIME= 1998-12-18T14:28:15.1172
USEABLE_STOP_TIME= 1998-12-18T14:28:45.1172
ORB_TYPE = CARTPVA
ORB_UNITS = [km,km,km,km/s,km/s,km/s,km/s**2,km/s**2,km/s**2]
0.000000 2789.6 -280.0 -1746.8 4.73 -2.50 -1.04 0.008 0.001 -0.159
10.000000 2783.4 -308.1 -1877.1 5.19 -2.42 -2.00 0.008 0.001 0.001
20.000000 2776.0 -336.9 -2008.7 5.64 -2.34 -1.95 0.008 0.001 0.159
< intervening data records omitted here >
1998-12-18T14:36:35.117250.000000 2164.375 1115.811 -688.131 -3.53328 -2.88452 0.88535
ORB_STOP

ORB_START
ORB_BASIS = DETERMINED_OD
ORB_REF_FRAME = J2000
ORB_TYPE = KPLR
ORB_UNITS = [km, nd, deg, deg, deg, deg]
0.000000 6600.0 .03 28.5 50.0 30.0 10.0
10.000000 6600.0 .03 28.5 50.0 30.0 10.1
20.000000 6600.0 .03 28.5 50.0 30.0 10.2
< intervening data records omitted here >
500.000000 6600.0 .03 28.5 50.0 30.0 35.0
ORB_STOP

PHYS_START
COMMENT Spacecraft Physical Characteristics:
DRAG_ADDL_AREA = 10.00 [m**2]
DRAG_COEFF = NOM = 2.300
MASS = 100.0 [kg]
SOLAR_RADS_RP_ADDL_AREA = 4.00
SOLAR_RAD_COEFF = 1.300
PHYS_STOP

MAN_START
COMMENT = 200 s of 10N thrust (in-track transitioning to radial)
COMMENT = w/effic η=0.95, Isp=300s, 5% 1-sigma error
MAN_ID = E_W_20160305B
MAN_BASIS = PREDICTEDCANDIDATE
MAN_IS_ADDITIVE = YESDEVICE_ID = THR_01
MAN_PURPOSE = ORBIT_ADJUST
MAN_BOI = MAN_DURA, THR_X, THR_Y, THR_Z, THR_SIGMA, THR_INTERP, THR_ISP, THR_EFFIC
MAN_REF_FRAME = RTN
MAN_COMPOSITION = MAN_DURA, THR_X, THR_Y, THR_Z, THR_SIGMA, THR_INTERP, THR_ISP, THR_EFFIC
MAN_UNITS = [s, N, N, N, %, nd, s, nd]
500.0 100.0 -0.0 10.0 0.0 5.0 -ON 300.0 0.95
600.0 100.0 10.0- 0.0 0.0 5.0 OFF 300.0 0.95
MAN_STOP

PERT_START
COMMENT Perturbations specification
GM = 398600.4415 [km**3/s**2]

```

PERT_STOP	
OD_START	
COMMENT	Orbit Determination information
OD_ID	= OD #10059
OD_PREV_ID	= OD #10058
OD_METHOD	= BWLS: BAHN
OD_EPOCH	= 2001-11-06T11:17:33
OBS_USED	= 273
TRACKS_USED	= 91
OD_STOP	

Fig. G-4: OCM example with multiple orbit time histories, a maneuver, OD, Cartesian & Keplerian ephemeris

CCSDS PROPOSED STANDARD FOR ORBIT DATA MESSAGES

```

CCSDS_OCM_VERS  -= 3.0

CREATION_DATE   = 1998-11-06T09:23:57
ORIGINATOR      = JAXA

META_START
OBJECT_NAME     = OSPREY 5
INTERNATIONAL_DESIGNATOR = 1998-999A
TIME_SYSTEM     = UTC
EPOCH_TZERO    = 1998-12-18T14:28:15.1172
TIME_SYSTEM = UTC
META_STOP

ORB_START
COMMENT         = GEOCENTRIC, CARTESIAN, EARTH FIXED
ORB_BASIS       = PREDICTED
CENTER_NAME     = EARTH
ORB_REF_FRAME   = TOD_EARTH
ORB_FRAME_EPOCH = 1998-12-18T14:28:15.1172
ORB_TYPE        = CARTPVA

  0.000000 2789.6 -280.0 -1746.8 4.73 -2.50 -1.04 0.008 0.001 -0.159
 10.000000 2783.4 -308.1 -1877.1 5.19 -2.42 -2.00 0.008 0.001 0.001
 20.000000 2776.0 -336.9 -2008.7 5.64 -2.34 -1.95 0.008 0.001 0.159
  < intervening data records omitted here >
 500.000000 2164.375 1115.811 -688.131 -3.53328 -2.88452 0.88535
ORB_STOP

PHYS_START
COMMENT Spacecraft Physical Characteristics:
DRAG_ADDL_AREA   = 10.000 [m**2]
DRAG_COEFF_NOM   = 2.300
MASS             = 1913.000 [kg]
SOLAR_RADSRP_ADDL_AREA = 10.000 [m**2]
SOLAR_RAD_COEFF = 1.300
PHYS_STOP

COV_START
COV_BASIS        = PREDICTED
COV_REF_FRAME    = J2000
COV_TYPE         = ADBARV

COV_UNITS        = [deg, deg, deg, deg, km, km/s]
10.00
  3.331349e-04
  - 4.618927e-04  6.782421e-04
  - -3.070007e-04 -4.221234e-04 <cont.> 3.231931e-04
  - -3.349365e-07 -4.686084e-07  2.484949e-07  4.296022e-10 <cont.>
  -2.211832e-07 -2.864186e-07  1.798098e-07  2.608899e-10  1.767514e-10 <cont.>
  -3.041346e-07 -4.989496e-07  3.540310e-07  1.869263e-10  1.008862e-10  6.224444e-10
  < .. intervening data records omitted here .. >
20.0
  3.442450e-04
  - 4.507816e-04  6.893532e-04
  - -3.060006e-04 -4.110123e-04 <cont.> 3.342042e-04
  - -3.238254e-07 -4.575073e-07  2.373838e-07  4.307133e-10 <cont.>
  -2.100721e-07 -2.753075e-07  1.687087e-07  2.507788e-10  1.878625e-10 <cont.>
  -3.030235e-07 -4.878385e-07  3.430200e-07  1.758152e-10  1.007751e-10  6.224444e-10
COV_STOP

COV_START
COV_BASIS        = PREDICTED
COV_REF_FRAME    = EFG
COV_TYPE         = EFG
COV_UNITS        = [km, km, km]
1998-12-18T14:31:35.1172
  3.331349e-04
  - 4.618927e-04  6.782421e-04
  - -3.070007e-04 <cont.> -4.221234e-04  3.231931e-04
COV_STOP

```

```

PERT_START
COMMENT Perturbations specification
GM          = 398600.4415          [km**3/s**2]
PERT_STOP
    
```

Fig. G-5: OCM example with Covariance Matrix

```

CCSDS_OCM_VERSION = 3.0
CREATION_DATE      = 1998-11-06T09:23:57
ORIGINATOR         = JAXA

META_START
OBJECT_NAME        = OSPREY-5
INTERNATIONAL_DESIGNATOR = 1998-999A
EPOCH_TZERO       = 1998-12-18T14:28:15.1172
META_STOP

STM_START
COMMENT HERE IS A STATE TRANSITION MATRIX DATA BLOCK+
STM_MAP_MODE       = STATE
STM_ORB_TIME       = 0.0
STM_ORB_STATE      = 2789.6 280.0 1746.8 4.73 2.50 1.04
STM_REF_FRAME      = ICRF3
STM_TYPE           = CARTPV

DT = 0.00
1.0 0.0 0.0 0.0 0.0 0.0
0.0 1.0 0.0 0.0 0.0 0.0
0.0 0.0 1.0 0.0 0.0 0.0
0.0 0.0 0.0 1.0 0.0 0.0
0.0 0.0 0.0 0.0 1.0 0.0
0.0 0.0 0.0 0.0 0.0 1.0

< intervening data records omitted here >

DT = 500.00
1.23456 7.89012 3.45678 9.01234 5.67890 1.23456
7.89012 3.45678 9.01234 5.67890 1.23456 7.89012
3.45678 9.01234 5.67890 1.23456 7.89012 3.45678
9.01234 5.67890 1.23456 7.89012 3.45678 9.01234
5.67890 1.23456 7.89012 3.45678 9.01234 5.67890
1.23456 7.89012 3.45678 9.01234 5.67890 1.23456
STM_STOP
    
    
```

Fig. G-6: OCM example with STM (Cartesian position and velocity elements)

NOTE: The demarcation “<cont.>” indicates that this single line is shown, for display purposes only, in multiple lines. This demarcation shall not be used in the actual OCM message, as all specified content shall be provided on the same line as its matching time tag.

OCM example in XML:

~~Fig. G 7 contains~~The following is an example of an Orbit Comprehensive Message in Extensible Markup Language (XML) format.

CCSDS PROPOSED STANDARD FOR ORBIT DATA MESSAGES

```

<?xml version="1.0" encoding="UTF-8"?>
<ocm xmlns:xsi="http://www.w3.org/2001/XMLSchema-instance"
  xsi:noNamespaceSchemaLocation="file:///Y:/Desktop/ccsds-ndmxml/ndmxml-
  1.0.x-schemas-unqualified/ndmxml-1.0-master.xsd"
  id="CCSDS_OCM_VERS" version="P2.39">
  - <header>
  - <COMMENT>ODM V.3 Example G-2</COMMENT>
  - <COMMENT>OCM example with space object characteristics and
  perturbations.</COMMENT>
  - <COMMENT>This OCM reflects the latest conditions post-maneuver A67Z</COMMENT>
  - <COMMENT>This example shows the specification of multiple comment
  lines</COMMENT>
  - <CREATION_DATE>1998-11-06T09:23:57</CREATION_DATE>
  - <ORIGINATOR>JAXA</ORIGINATOR>
  - <MESSAGE_ID> OCM 201113719185</MESSAGE_ID> </header>
  - <body>
  - <segment>
  - <metadata>
  - <OBJECT_NAME>OSPREY 5</OBJECT_NAME>
  - <INTERNATIONAL DESIGNATOR>1998-999A</INTERNATIONAL DESIGNATOR>
  - <ORIGINATOR_POC>R. Rabbit</ORIGINATOR_POC>
  - <ORIGINATOR_POSITION>Flight Dynamics Mission Design
  Lead</ORIGINATOR_POSITION>
  - <ORIGINATOR_PHONE>(719)555-1234</ORIGINATOR_PHONE>
  - <TECH_POC>Mr. Rodgers</TECH_POC>
  - <TECH_PHONE>(719)555-1234</TECH_PHONE>
  - <TECH_ADDRESS>email@email.XXX</TECH_ADDRESS>
  - <OBJECT_NAME>OSPREY 5</OBJECT_NAME>
  - <INTERNATIONAL DESIGNATOR>1998-999A</INTERNATIONAL DESIGNATOR>
  - <TIME_SYSTEM>UT1</TIME_SYSTEM>
  - <EPOCH_TZERO>1998-12-18T00:00:00.0000</EPOCH_TZERO>
  - <TAIMUTC_AT_TZERO units="s">36</TAIMUTC_AT_TZERO>
  - <UT1MUTC_AT_TZERO units="s">.357</UT1MUTC_AT_TZERO>
  - </metadata>
  - <data>
  - <orbitState<orbit>
  - <COMMENT>GEOCENTRIC, CARTESIAN, EARTH FIXED</COMMENT>
  - <COMMENT>THIS IS MY SECOND COMMENT LINE</COMMENT>
  - <ORB_BASIS>PREDICTED</ORB_BASIS >
  - <ORB_REF_FRAME>EFG</ORB_REF_FRAME>
  - <ORB_TYPE>CARTPVA</ORB_TYPE>
  - <orbitLine>0.000000 2789.6 -280.0 -1746.8 4.73 -2.50 -1.04 0.008
  0.001 -0.159</orbitLine>
  - </orbitState</orbit>
  - <physicalDescription<physical>
  - <COMMENT>Spacecraft Physical Characteristics</COMMENT>
  - <MASS units="kg">100.0</MASS>
  - <OEB_Q1>0.03123</OEB_Q1>
  - <OEB_Q2>0.78543</OEB_Q2>
  - <OEB_Q3>0.39158</OEB_Q3>
  - <OEB_QC>0.47832</OEB_QC>
  - <OEB_MAX units="m">2.0</OEB_MAX>
  - <OEB_MEDINT units="m">1.0</OEB_MEDINT>
  - <OEB_MIN units="m">0.5</OEB_MIN>
  - <AREA_ALONG_OEB_MAX units="m**2">0.15</AREA_ALONG_OEB_MAX>
  - <AREA_ALONG_OEB_MEDINT units="m**2">0.3</AREA_ALONG_OEB_MEDINT>
  - <AREA_ALONG_OEB_MIN units="m**2">0.5</AREA_ALONG_OEB_MIN>
  - </physicalDescription</physical>
  - <perturbations>
  - <COMMENT>Perturbations Specification</COMMENT>
  - <ATMOSPHERIC_MODEL>NRLMSIS00</ATMOSPHERIC_MODEL>
  - <GRAVITY_MODEL>EGM-96: 36D 36O</GRAVITY_MODEL>
  - <GM units="km**3/s**2">398600.4415</GM>
  - <N_BODY_PERTURBATIONS>MOON, SUN</N_BODY_PERTURBATIONS>
  - <FIXED_GEOMAG_KP>12.0</FIXED_GEOMAG_KP>
  - <FIXED_F10P7>105.0</FIXED_F10P7>
  - <FIXED_F10P7_MEAN>120.0</FIXED_F10P7_MEAN>
  - </perturbations>
  - <userDefinedParameters>
  - <USER_DEFINED parameter="EARTH_MODEL">WGS-84</USER_DEFINED>
  - </userDefinedParameters>

```

```
— </data>  
— </segment>  
— </body>  
</ocm>
```

Fig. G-6: OCM file-example in Extensible Markup Language (XML) format.

ANNEX H

AGGREGATING MULTIPLE ODMS IN A SINGLE NDM XML FILE

(INFORMATIVE)

The following example illustrates how multiple Orbit Data Messages can be aggregated in a single XML file using the Navigation Data Message (NDM) "combined instantiation" schema.

```

<ndm xmlns:xsi="http://www.w3.org/2001/XMLSchema-instance"
xsi:noNamespaceSchemaLocation="https://sanaregistry.org/r/ndmxml/ndmxml-1.0-
master.xsd">
  <omm id="CCSDS_OMM_VERS" version="2.0">
    <header>
      <COMMENT>GENERATED VIA SPACE-TRACK.ORG API</COMMENT>
      <CREATION_DATE>2020-05-16T14:00:01</CREATION_DATE>
      <ORIGINATOR>18 SPCS</ORIGINATOR>
    </header>
    <body>
      <segment>
        <metadata>
          <OBJECT_NAME>STARLINK-1073</OBJECT_NAME>
          <OBJECT_ID>2020-001A</OBJECT_ID>
          <CENTER_NAME>EARTH</CENTER_NAME>
          <REF_FRAME>TEMEOFDATE</REF_FRAME>
          <TIME_SYSTEM>UTC</TIME_SYSTEM>
          <MEAN_ELEMENT_THEORY>SGP4</MEAN_ELEMENT_THEORY>
        </metadata>
        <data>
          <meanElements>
            <EPOCH>2020-05-16T14:00:01</EPOCH>
            <MEAN_MOTION>15.05566242</MEAN_MOTION>
            <ECCENTRICITY>0.0001225</ECCENTRICITY>
            <INCLINATION>52.9981</INCLINATION>
            <RA_OF_ASC_NODE>157.6133</RA_OF_ASC_NODE>
            <ARG_OF_PERICENTER>93.35</ARG_OF_PERICENTER>
            <MEAN_ANOMALY>295.8599</MEAN_ANOMALY>
          </meanElements>
          <tleParameters>
            <EPHEMERIS_TYPE>0</EPHEMERIS_TYPE>
            <CLASSIFICATION_TYPE>U</CLASSIFICATION_TYPE>
            <NORAD_CAT_ID>44914</NORAD_CAT_ID>
            <ELEMENT_SET_NO>999</ELEMENT_SET_NO>
            <REV_AT_EPOCH>176</REV_AT_EPOCH>
            <BSTAR>0.00057678</BSTAR>
            <MEAN_MOTION_DOT>0.00008131</MEAN_MOTION_DOT>
            <MEAN_MOTION_DDOT>0</MEAN_MOTION_DDOT>
          </tleParameters>
          <userDefinedParameters>
            <USER_DEFINED parameter="TLE_LINE0">0 STARLINK-1073</USER_DEFINED>
            <USER_DEFINED parameter="TLE_LINE1">
              1 44914U 20001A 20137.58334491 +.00008131 +00000-0 +57678-3 0 9994
            </USER_DEFINED>
            <USER_DEFINED parameter="TLE_LINE2">
              2 44914 052.9981 157.6133 0001225 093.3500 295.8599
              15.05566242001761
            </USER_DEFINED>
          </userDefinedParameters>
        </data>
      </segment>
    </body>
  </omm>
  <omm id="CCSDS_OMM_VERS" version="2.0">
    <header>
      <COMMENT>GENERATED VIA SPACE-TRACK.ORG API</COMMENT>
      <CREATION_DATE>2020-05-16T14:00:01</CREATION_DATE>
      <ORIGINATOR>18 SPCS</ORIGINATOR>
    </header>
    <body>
      <segment>
        <metadata>
          <OBJECT_NAME>STARLINK-1084</OBJECT_NAME>
          <OBJECT_ID>2020-001B</OBJECT_ID>
          <CENTER_NAME>EARTH</CENTER_NAME>
          <REF_FRAME>TEMEOFDATE</REF_FRAME>
          <TIME_SYSTEM>UTC</TIME_SYSTEM>
          <MEAN_ELEMENT_THEORY>SGP4</MEAN_ELEMENT_THEORY>
        </metadata>

```

CCSDS PROPOSED STANDARD FOR ORBIT DATA MESSAGES

```

<data>
  <meanElements>
    <EPOCH>2020-05-16T14:00:01</EPOCH>
    <MEAN_MOTION>15.05603711</MEAN_MOTION>
    <ECCENTRICITY>0.000126</ECCENTRICITY>
    <INCLINATION>52.9991</INCLINATION>
    <RA_OF_ASC_NODE>157.611</RA_OF_ASC_NODE>
    <ARG_OF_PERICENTER>75.9191</ARG_OF_PERICENTER>
    <MEAN_ANOMALY>151.2104</MEAN_ANOMALY>
  </meanElements>
  <tleParameters>
    <EPHEMERIS_TYPE>0</EPHEMERIS_TYPE>
    <CLASSIFICATION_TYPE>U</CLASSIFICATION_TYPE>
    <NORAD_CAT_ID>44915</NORAD_CAT_ID>
    <ELEMENT_SET_NO>999</ELEMENT_SET_NO>
    <REV_AT_EPOCH>1986</REV_AT_EPOCH>
    <BSTAR>0.0006442</BSTAR>
    <MEAN_MOTION_DOT>0.00009125</MEAN_MOTION_DOT>
    <MEAN_MOTION_DDOT>0</MEAN_MOTION_DDOT>
  </tleParameters>
  <userDefinedParameters>
    <USER_DEFINED parameter="TLE_LINE0">0 STARLINK-1084</USER_DEFINED>
    <USER_DEFINED parameter="TLE_LINE1">
      1 44915U 20001B 20137.58334491 +.00009125 +00000-0 +64420-3 0 9992
    </USER_DEFINED>
    <USER_DEFINED parameter="TLE_LINE2">
      2 44915 052.9991 157.6110 0001260 075.9191 151.2104
      15.05603711019869
    </USER_DEFINED>
  </userDefinedParameters>
</data>
</segment>
</body>
</omm>
<omm id="CCSDS_OMM_VERS" version="2.0">
  <header>
    <COMMENT>GENERATED VIA SPACE-TRACK.ORG API</COMMENT>
    <CREATION_DATE>2020-05-16T14:00:01</CREATION_DATE>
    <ORIGINATOR>18 SPCS</ORIGINATOR>
  </header>
  <body>
    <segment>
      <metadata>
        <OBJECT_NAME>STARLINK-1097</OBJECT_NAME>
        <OBJECT_ID>2020-001C</OBJECT_ID>
        <CENTER_NAME>EARTH</CENTER_NAME>
        <REF_FRAME>TEMEOFDATE</REF_FRAME>
        <TIME_SYSTEM>UTC</TIME_SYSTEM>
        <MEAN_ELEMENT_THEORY>SGP4</MEAN_ELEMENT_THEORY>
      </metadata>
      <data>
        <meanElements>
          <EPOCH>2020-05-16T14:00:01</EPOCH>
          <MEAN_MOTION>15.0559315</MEAN_MOTION>
          <ECCENTRICITY>0.0001361</ECCENTRICITY>
          <INCLINATION>52.999</INCLINATION>
          <RA_OF_ASC_NODE>157.6123</RA_OF_ASC_NODE>
          <ARG_OF_PERICENTER>94.2334</ARG_OF_PERICENTER>
          <MEAN_ANOMALY>78.9025</MEAN_ANOMALY>
        </meanElements>
        <tleParameters>
          <EPHEMERIS_TYPE>0</EPHEMERIS_TYPE>
          <CLASSIFICATION_TYPE>U</CLASSIFICATION_TYPE>
          <NORAD_CAT_ID>44916</NORAD_CAT_ID>
          <ELEMENT_SET_NO>999</ELEMENT_SET_NO>
          <REV_AT_EPOCH>1986</REV_AT_EPOCH>
          <BSTAR>0.00072742</BSTAR>
          <MEAN_MOTION_DOT>0.00010329</MEAN_MOTION_DOT>
          <MEAN_MOTION_DDOT>0</MEAN_MOTION_DDOT>
        </tleParameters>
        <userDefinedParameters>

```



```

<USER_DEFINED parameter="TLE_LINE0">0 STARLINK-1097</USER_DEFINED>
<USER_DEFINED parameter="TLE_LINE1">
  1 44916U 20001C 20137.58334491 +.00010329 +00000-0 +72742-3 0 9997
</USER_DEFINED>
<USER_DEFINED parameter="TLE_LINE2">
  2 44916 052.9990 157.6123 0001361 094.2334 078.9025
15.05559315019865
</USER_DEFINED>
</userDefinedParameters>
</data>
</segment>
</body>
</omm>
</ndm>

```

Fig. H-1: Aggregating multiple ODMs into a single NDM file

~~ANNEX HANNEX I~~**ABBREVIATIONS AND ACRONYMS****(INFORMATIVE)**

ASCII	American Standard Code for Information Interchange
CCSDS	Consultative Committee for Space Data Systems
CIO	Celestial Intermediate Origin
CIP	Celestial Intermediate Pole
DSST	Draper Semi-Analytic Satellite Theory
EGM	Earth Gravitational Model, Earth Geopotential Model
EOP	Earth Orientation Parameters
GPS	Global Positioning System
IAU	International Astronomical Union
ICD	Interface Control Document
ICRF	International Celestial Reference Frame
IEC	International Electro-technical Commission
IERS	International Earth Rotation and Reference Systems Service
IIRV	Improved Inter-Range Vector
ISO	International Standards Organization
ITRF	International Terrestrial Reference Frame
GRC	Greenwich Rotating Coordinate Frame
J2000	Earth Mean Equator and Equinox of J2000 (Julian Date 2000)
KVN	Keyword = Value Notation
NORAD	North American Aerospace Defense Command
OD	Orbit Determination
ODM	Orbit Data Message

OEB	Optimally-Encompassing Box
OEM	Orbit Ephemeris Message
OCM	Orbit Comprehensive Message
OMM	Orbit Mean-Elements Message
OPM	Orbit Parameter Message
RTN	Radial, Transverse (along-track), and Normal
S/C	Spacecraft
SGP4	US Air Force Simplified General Perturbations No. 4
SPK	Satellite, Planetary Kernel
TAI	International Atomic Time
TCB	Barycentric Coordinate Time
TDB	Barycentric Dynamical Time
TDR	True of Date Rotating
TDT	Terrestrial Dynamical Time (see also ‘TT’)
TEME	True Equator Mean Equinox
TLE	Two Line Element
TOD	True Equator and Equinox of Date
TT	Terrestrial Dynamical Time (see also ‘TDT’)
USM	Universal Semi-analytical Method
UTC	Coordinated Universal Time
W3C	World Wide Web Consortium
WGS	World Geodetic System
XML	Extensible Markup Language

~~ANNEX I~~ ANNEX J**RATIONALE FOR ORBIT DATA MESSAGES****(INFORMATIVE)****HJ1 OVERVIEW**

This annex presents the rationale behind the design of each message. It may help the application engineer to select a suitable message.

A specification of requirements agreed to by all parties is essential to focus design and to ensure the product meets the needs of the Member Agencies and satellite operators. There are many ways of organizing requirements, but the categorization of requirements is not as important as the agreement to a sufficiently comprehensive set. In this section the requirements are organized into three categories:

- a) **Primary Requirements:** These are the most elementary and necessary requirements. They would exist no matter the context in which the CCSDS is operating, i.e., regardless of pre-existing conditions within the CCSDS, its Member Agencies, or other independent users.
- b) **Heritage Requirements:** These are additional requirements that derive from pre-existing Member Agency or other independent user requirements, conditions or needs. Ultimately these carry the same weight as the Primary Requirements. This Recommended Standard reflects heritage requirements pertaining to some of the CCSDS Areas' home institutions collected during the preparation of the document; it does not speculate on heritage requirements that could arise from other sources. Corrections and/or additions to these requirements are expected during future updates.
- c) **Desirable Characteristics:** These are not requirements, but they are felt to be important or useful features of the Recommended Standard.

12.2 PRIMARY REQUIREMENTS ACCEPTED BY THE ORBIT DATA MESSAGES

12.1J2.1 PRIMARY REQUIREMENTS

#	Requirement	OPM?	OMM?	OEM?	OCM?
P1	Data must be provided in digital form (computer file).	Y	Y	Y	Y
P2	The file specification must not require of the receiving exchange partner the separate application of, or modeling of, spacecraft dynamics or gravitational force models, or integration or propagation.	N	N	Y	Y
P3	The interface must facilitate the receiver of the message to generate a six-component Cartesian state vector (position and velocity) at any required epoch.	Y	Y	Y	Y
P4	State vector information must be provided in a reference frame that is clearly identified and unambiguous.	Y	Y	Y	Y
P5	Identification of the object and the center(s) of motion must be clearly identified and unambiguous.	Y	Y	Y	Y
P6	Time measurements (time stamps, or epochs) must be provided in a commonly used, clearly specified system.	Y	Y	Y	Y
P7	The time bounds of the ephemeris must be unambiguously specified.	N/A	N/A	Y	Y
P8	The Recommended Standard must provide for clear specification of units of measure.	Y	Y	Y	Y
P9	Files must be readily ported between, and useable within, 'all' computational environments in use by Member Agencies.	Y	Y	Y	Y
P10	Files must have means of being uniquely identified and clearly annotated. The file name alone is considered insufficient for this purpose.	Y	Y	Y	Y
P11	File name syntax and length must not violate computer constraints for those computing environments in use by Member Agencies.	Y	Y	Y	Y
P12	A means to convey information about the uncertainty of the state shall be provided.	Y	Y	Y	Y

12.2J2.2 HERITAGE REQUIREMENTS

#	Requirement	OPM?	OMM?	OEM?	OCM?
H1	Ephemeris data is reliably convertible into the SPICE SPK (NASA) format (reference (M-4) (N-4)) and IIRV (NASA) format (reference (M-5) (N-5)) using a standard, multi-mission, unsupervised pipeline process. A complete ephemeris, not subject to integration or propagation by the customer, must be provided.	N	N	Y	Y
H2	Ephemeris data provided for scheduling or operations (metric predicts) is to be certified by the providing Agency as correct and complete for the intended purpose. The receiving Agency cannot provide evaluation, trajectory propagation or other usability services.	N	N	Y	Y

#	Requirement	OPM?	OMM?	OEM?	OCM?
H3	The ODM shall provide a mechanism by which messages may be uniquely identified and clearly annotated. Facilitates discussion between the recipient and the message originator, should that be necessary.	Y	Y	Y	Y
H4	The ODM shall provide a mechanism by which maneuvers may be uniquely identified and clearly annotated. Facilitates discussion between the recipient and the message originator, should that be necessary.	N	N	N	Y
H5	The Recommended Standard is, or includes, an ASCII format.	Y	Y	Y	Y
H6	The Recommended Standard does not require software supplied by other Agencies.	Y	N	Y	Y

12.3J2.3 DESIRABLE CHARACTERISTICS

#	Requirement	OPM?	OMM?	OEM?	OCM?
DC1	The Recommended Standard applies to non-traditional objects, such as landers, rovers, balloons, and natural bodies (asteroids, comets).	Y	N	Y	Y
DC2	The Recommended Standard allows state vectors to be provided in other than the traditional J2000 inertial reference frame; one example is the International Astronomical Union (IAU) Mars body-fixed frame. (In such a case, provision or ready availability of supplemental information needed to transform data into a standard frame must be arranged.)	Y	Y	Y	Y
DC3	The Recommended Standard is extensible with no disruption to existing users/uses.	Y	Y	Y	Y
DC4	The Recommended Standard is consistent with, and ideally a part of, ephemeris products and processes used for other space science purposes.	Y	Y	Y	Y
DC5	The Recommended Standard is as consistent as reasonable with any related CCSDS ephemeris Recommended Standards used for earth-to-spacecraft or spacecraft-to-spacecraft applications.	Y	Y	Y	Y

12.4J2.4 APPLICABILITY OF CRITERIA TO MESSAGE OPTIONS

The selection of one particular message will depend on the optimization criteria in the given application. Section 12J2.5 compares the four recommended messages in terms of the relevant selection criteria identified by the CCSDS:

12.5J2.5 APPLICABILITY OF THE CRITERIA TO ORBIT DATA MESSAGES

Criteria	Definition	Applicable to OPM?	Applicable to OMM?	Applicable to OEM?	Applicable to OCM?
Modeling Fidelity	Permits modeling of any dynamic perturbation to the trajectory.	N	N	Y	Y
Human Readability	Provides easily readable message corresponding to widely used orbit representation.	Y	Y	Y	Y
Remote Body Extensibility	Permits use for assets on remote solar system bodies.	Y	N	Y	Y
Lander/Rover Compatibility	Permits exchange of non-orbit trajectories.	N	N	Y	Y

13J3 INCREASING ORBIT PROPAGATION FIDELITY OF AN OPM OR OMM

Some OPM or OMM users may desire/require a higher fidelity propagation of the state vector or Keplerian elements. A higher fidelity technique may be desired/required to minimize inconsistencies in predictions generated by diverse, often operator-unique propagation schemes. Nominally the OPM and OMM are engineered only for low- to medium-fidelity orbit propagation. However, with the inclusion of additional context information, it is possible for users to provide data that could be used to provide a relatively higher fidelity orbit propagation. For this relatively higher fidelity orbit propagation, a much greater amount of ancillary information regarding spacecraft properties and dynamical models should be provided. Higher fidelity orbit propagations may be useful in special studies such as orbit conjunction studies.

Spacecraft orbit determination is a stochastic estimation problem; observations are inherently uncertain, and not all of the phenomena that influence satellite motion are clearly discernible. State vectors and Keplerian elements with their respective covariances are best propagated with models that include the same forces and phenomena that were used for determining the orbit. Including this information in an OPM or OMM allows exchange partners to compare the results of their respective orbit propagations.

With additional context information, the OPM and OMM may be used for assessing mutual physical or electromagnetic interference among Earth-orbiting spacecraft, developing collaborative maneuvers, and propagating the orbits of active satellites, inactive man-made objects, and near-Earth debris fragments. The additional information facilitates dynamic modeling of any user's approach to conservative and non-conservative phenomena.

The primary vehicle for the provision of additional optional ancillary information to be used when propagating an OPM or OMM is the COMMENT mechanism. Alternatively, the 'USER_DEFINED_' keyword prefix may be used, though this usage is not encouraged.

14J4 SERVICES RELATED TO THE DIFFERENT ORBIT DATA MESSAGE FORMATS

The different orbit data messages have been distinguished by the self-interpretability of the messages. The different services that can be achieved without special arrangements between users of the CCSDS orbit data messages are listed in table [14J4.1](#).

14.1J4.1 SERVICES AVAILABLE WITH ORBIT DATA MESSAGES

Service	Definition	Applicable to OPM?	Applicable to OMM?	Applicable to OEM?	Applicable to OCM?
Absolute Orbit Interpretation	State availability at specific times for use in additional computations (geometry, event detection, etc.).	Y	Y	Y	Y
Relative Orbit Interpretation	Trajectory comparison and differencing for events based on the same time source.	Only at time specified at Epoch	Only at time specified at Epoch	Y	Y

~~ANNEX J~~ ANNEX K

ITEMS FOR AN INTERFACE CONTROL DOCUMENT (ICD)

(INFORMATIVE)

~~JK1~~ STANDARD ICD ITEMS

In several places in this document there are references to items which should be specified in an ICD between participants that supplements an exchange of ephemeris data. The ICD should be jointly produced by both participants in a cross-support involving the transfer of ephemeris data. This annex compiles those recommendations into a single section. Although the Orbit Data Messages described in this document may at times be used in situations in which participants have not negotiated ICDs, they should be developed and negotiated whenever ~~possible based on the content~~ specified in this Recommended Standard.¹

Item	Section
1) Definition of orbit accuracy requirements pertaining to any particular ODM.	1.2
2) Method of physically exchanging ODMs (transmission).	1.2, 3.1, 4.1, 5.1, 6.1
3) Whether the ASCII format of the ODM will be KVN or XML.	1.1
4) OPM, OMM, OEM, and/or OCM file naming conventions.	3.1, 4.1, 5.1, 6.1
5) Situations where the OBJECT_ID (or in the OCM, the OBJECT_DESIGNATOR) is not published in the UN OOSA index (reference [2]).	3.2.3, 4.2.3, 5.2.3, 6.2.3
6) 1) Detailed description of any user defined OPM, OMM, OEM, and OCM parameters used.	3.2.4, 4.2.4, 6.2.11, 3.2, 4.2, 5.2, 6.2
7) 2) ORB_AVERAGING Detailed description of any exceptions for keyword values not drawn from the SANA registry (sanaregistry.org)	6.2.4 Table 6-4 Annex B
8) OD_CONFIDENCE	6.2.10
9) OCM Max line length	7.3.3
10) Specific OPM, OMM OEM, and/or OCM version numbers that will be exchanged.	7.8.1

¹ EDITOR'S COMMENT: The greater the amount of material which must be specified via ICD, the lesser the utility/benefit of the ODM (custom programming may be required to tailor software for each ICD).

Item	Section
<p>113) Specific information security interoperability provisions that apply between agencies.</p>	<p>Annex L</p>
<p>12) Exceptions for Timing System, Reference Frame, Orbital Element, and Covariance Related keywords that are not drawn from ANNEX B (and the SANA registry, reference [10 — 18]) and when ORB_TYPE (6.2.4), COV_TYPE (6.2.6) and STM_TYPE (6.2.7) are =ICD</p>	<p>Annex B</p>
<p>13) Interpretation of TIME_SYSTEM specified as SCLK, if to be exchanged, and how to transform them to a standardized time system.</p>	<p>7.5.10 (provided that SCLK will be transformed to a standardized time system)</p>
<p>14) The ICD should specify that in using the timing format rules, elapsed days are to be used as relative time, with year starting at zero.</p>	<p>7.5.4</p>

~~ANNEX K~~ANNEX L**CHANGES IN ODM VERSION 3****(INFORMATIVE)**

This annex lists the differences between ODM 2.0 and ODM 3.0. The differences are divided into those which affect the content of one or more of the orbit data messages, and those which only affect the document.

~~Note that changes to previous versions of the ODM can be found in CCSDS Silver Book CCSDS 502.0 B-2 S, published November 2009.~~

K1L1 CHANGES IN THE MESSAGES

1. The Orbit Comprehensive Message (OCM) was added to provide better support for ISO Technical Committee 20, Subcommittee 14 objectives (see section 4).
2. MESSAGE_ID was added to the OPM, OMM, and OEM to provide better satisfaction of requirement P10 (identification and annotation of messages).

K2L2 CHANGES IN THE DOCUMENT

1. A new CCSDS repository for normative keyword values for navigation messages has been created at the SANA Registry, accessible on the Internet at: https://.../r/navigation_standard_normative_annexes. See Annex B for details on the affected keywords and links to the content. This content replaces non-normative references to the Navigation Green Book (reference ~~[M-1].[N-1]~~). The CCSDS documents are not allowed to make normative references to non-normative documents.
2. Several annexes were added. Some are required by CCSDS rule changes, and some are for the provision of supplementary material.
3. Examples for OPM, OMM, and OEM that formerly appeared in Sections 3, 4, and 5 respectively have been moved to Informative Annexes.
4. The "Checklist ICD" that was added in ODM Version 2 has been removed. It is replaced by the material that can be specified in the Orbit Comprehensive Message.

~~ANNEX L~~ ANNEX M**SECURITY, SANA, AND PATENT CONSIDERATIONS****L1M1 SECURITY CONSIDERATIONS****L1.1M1.1 ANALYSIS OF SECURITY CONSIDERATIONS**

This Section presents the results of an analysis of security considerations applied to the technologies specified in this Recommended Standard.

L1.2M1.2 CONSEQUENCES OF NOT APPLYING SECURITY TO THE TECHNOLOGY

The consequences of not applying security to the systems and networks on which this Recommended Standard is implemented could include potential loss, corruption, and theft of data. Because these messages are used in preparing pointing and frequency predicts used during spacecraft commanding, and may also be used in collision avoidance analyses, the consequences of not applying security to the systems and networks on which this Recommended Standard is implemented could include compromise or loss of the mission if malicious tampering of a particularly severe nature occurs.

L1.3M1.3 POTENTIAL THREATS AND ATTACK SCENARIOS

Potential threats or attack scenarios include, but are not limited to, (a) unauthorized access to the programs/processes that generate and interpret the messages, (b) unauthorized access to the messages during transmission between exchange partners and (c) modification of the messages between partners. Protection from unauthorized access during transmission is especially important if the mission utilizes open ground networks, such as the Internet, to provide ground-station connectivity for the exchange of data formatted in compliance with this Recommended Standard. It is strongly recommended that potential threats or attack scenarios applicable to the systems and networks on which this Recommended Standard is implemented be addressed by the management of those systems and networks.

L1.4M1.4 DATA PRIVACY

Privacy of data formatted in compliance with the specifications of this Recommended Standard should be assured by the systems and networks on which this Recommended Standard is implemented.

1.5M1.5 DATA INTEGRITY

Integrity of data formatted in compliance with the specifications of this Recommended Standard should be assured by the systems and networks on which this Recommended Standard is implemented.

1.6M1.6 AUTHENTICATION OF COMMUNICATING ENTITIES

Authentication of communicating entities involved in the transport of data which complies with the specifications of this Recommended Standard should be provided by the systems and networks on which this Recommended Standard is implemented.

1.7M1.7 DATA TRANSFER BETWEEN COMMUNICATING ENTITIES

The transfer of data formatted in compliance with this Recommended Standard between communicating entities should be accomplished via secure mechanisms approved by the Information Technology Security functionaries of exchange participants.

1.8M1.8 CONTROL OF ACCESS TO RESOURCES

Control of access to resources should be managed by the systems upon which originator formatting and recipient processing are performed.

1.9M1.9 AUDITING OF RESOURCE USAGE

Auditing of resource usage should be handled by the management of systems and networks on which this Recommended Standard is implemented.

1.10M1.10 UNAUTHORIZED ACCESS

Unauthorized access to the programs/processes that generate and interpret the messages should be prohibited in order to minimize potential threats and attack scenarios.

1.11M1.11 DATA SECURITY IMPLEMENTATION SPECIFICS

Specific information-security interoperability provisions that may apply between agencies and other independent users involved in an exchange of data formatted in compliance with this Recommended Standard could be specified in an ICD.

2M2 SANA CONSIDERATIONS

The following ODM-related items have been registered with the SANA Operator.

- The ODM-XML schema (see Section 88).

The following normative ODM elements shall be selected from the SANA registry (see Annex B):

- ODM Message ORIGINATORS;

- Spacecraft identifiers;
- Reference Frame Center and Third-Body Perturbations;
- Time Systems;
- Reference Frames (inertial, quasi-inertial, orbit-relative, spacecraft & attitude frames);
- Orbital element set and covariance column definitions.

The registration rule for new entries in the SANA registry is the approval of new requests by the CCSDS Area or Working Group responsible for the maintenance of the ODM at the time of the request. New requests for this registry should be sent to SANA (<mailto:info@sanaregistry.org>).

L3M3 PATENT CONSIDERATIONS

The recommendations of this document have no patent issues.

~~ANNEX MANNEX N~~

INFORMATIVE REFERENCES

(INFORMATIVE)

- [~~MN~~-1] *Navigation Data—Definitions and Conventions*. Report Concerning Space Data System Standards, CCSDS 500.0-G-~~34~~. Green Book. Issue ~~34~~. Washington, D.C.: CCSDS, ~~May 2010~~November 2019
- [~~MN~~-2] “CelesTrak.” Center for Space Standards & Innovation (CSSI). <<http://celestrak.com/>>
- [~~MN~~-3] David A. Vallado, et al. “Revisiting Spacetrack Report #3.” In *Proceedings of the AIAA/AAS Astrodynamics Specialist Conference and Exhibit* (21–24 August 2006, Keystone, Colorado). AIAA 2006-6753. Reston, Virginia: AIAA, 2006. <<http://www.centerforspace.com/downloads/files/pubs/AIAA-2006-6753.pdf>>
- [~~MN~~-4] “Documentation.” *SPICE: NASA’s Solar System Exploration Ancillary Information System*. Navigation and Ancillary Information Facility (NAIF). <<http://naif.jpl.nasa.gov/naif/documentation.html>>
- [~~MN~~-5] *Ground Network Tracking and Acquisition Data Handbook*. 453-HNDK-GN. Greenbelt, Maryland: Goddard Space Flight Center, May 2007, http://imbrium.mit.edu/LRORS/DOCUMENT/453_HDBK_GN.PDF .
- [~~MN~~-6] Oltrogge, D.L., et al, “Ephemeris Requirements for Space Situational Awareness,” AAS 11-151, February 2011-, <https://www.agi.com/resources/white-papers/ephemeris-requirements-for-space-situational-aware>.
- [~~MN~~-7] David A. Vallado, et al. *Fundamentals of Astrodynamics and Applications*, 4th Ed., Microcosm Press and Springer, ISBN 978-1881883180.
- [~~MN~~-8] Oltrogge, D.L., North, P. and Nicholls, M., “Multi-Phenomenology Observation Network Evaluation Tool (MONET),” AMOS 2015 Space Situational Awareness Conference, Maui, HI, September 2015-, <https://www.agi.com/resources/white-papers/multi-phenomenology-observation-network-evaluation>.
- [~~MN~~-9] ~~Woodburn, J.,~~ Tanygin, S., “Attitude Interpolation,” AAS Spaceflight Mechanics Conference 2003, <https://www.agi.com/resources/white-papers/attitude-interpolation>.
- [N-10] Tanygin, S., “Efficient Covariance Interpolation Using Blending of Approximate State Error Transitions. AAS Spaceflight Mechanics Conference 2013, <https://www.agi.com/resources/white-papers/efficient-covariance-interpolation-using-blending>.

- [N-11] Woodburn, J., & Tanygin, S. (2002). Position covariance visualization. AIAA/AAS Astrodynamics Specialist Conference and Exhibit, Monterey, California, https://www.researchgate.net/profile/Sergei_Tanygin/publication/265672620-Attitude-Covariance-Visualization/links/54d578b10cf25013d02b3819/Attitude-Covariance-Visualization.pdf<https://www.agi.com/resources/white-papers/position-covariance-visualization>.
- [MN-12] ESA Space Debris DISCOS Database website, <https://discosweb.esoc.esa.int/group/guest/statistics>.
- [MN-13] Kaplan, E.D. and Hegarty, C., *Understanding GPS/GNSS: Principles and Applications, 3rd. Edition*,. Artech House Publishing, ISBN-13: 978-1630810580, 2017, available at https://www.navtechgps.com/understanding_gpsgnss_principles_and_applications_3rd_edition/.
- [N-14] Sands, O.S, Connolly, J.W, Welch, B.W., Carpenter, J.R., Ely, T.A., Berry, K.T., “Dilution of Precision-Based Lunar Navigation Assessment for Dynamic Position Fixing”, ntrs.nasa.gov, NASA/TM-2006-214247, 2006.
- [N-15] Peter C. Hughes, *Spacecraft Attitude Dynamics*, John Wiley and Sons Inc., ISBN 0-471-81842-9.