

**Technical Note Concerning Space Data System
Standards**

**FUNCTIONAL RESOURCE
REFERENCE MODEL**

DRAFT TECHNICAL NOTE

CSSA 1-TN-0.11

July 2016

BOOK CAPTAIN'S NOTES

This book needs major updating, as many top-level concepts as well as low-level details have changed. In this section I will summarize the some of the global changes that need to be made. Throughout the book, lower-level changes that are needed are called out in comments. However, no promises are made about the completeness of the identification of the needed changes – these are just things that have been noted until now.

Demotion of Service Component Concept and New Terminology

The most significant change to affect the Functional Resource Reference Model coming out of the Spring 2016 Workshop was the demotion of the Service Component concept as a Service Management-instance entity with formal parameters to a concept for classifying and sets of functional resources. Also, because the term “Service Component” appears to be susceptible to being confused with real equipment implementations, the terminology must change. To put the focus back on the core of these groupings - the functional resources – it was decided in Cleveland that “Service Component” is to be replaced with “Functional Resource Set”. Note that the name of this Tech Note has changed from *Functional Resource and Service Component Reference Model* to the simpler *Functional Resource Reference Model*.

It remains useful to have a concept for an abstraction above the level of individual, concrete Service Components/Functional Resource Sets. In the previous model, this level of abstraction was fulfilled by the Abstract Service Component, an abstraction the represents a “layer” of space link communication and radiometric functionality that can be met by multiple specializations (e.g, RF Antenna as a specialization of the Aperture). The term that I propose to use for this level of abstraction is “Functional Resource Strata”, in which a particular “layer” (e.g., Aperture) is referred to as a “Functional Resource stratum”. I propose strata/stratum because of its inherent similarity to “layer”, but by being different words from “layer” specifically we can (hopefully) distinguish these abstract entities from the ISO/OSI Layered Model.

Changing from Abstract Service Component/Service Component to Functional Resource Strata/Functional Resource Set is only in part a find-and-replace activity. There are also conceptual differences. In the Service Component-based Reference Model, the Service Components themselves were management entities – e.g., they had counterparts in the Service Agreements and Configuration Profiles that had OIDs and instance numbers. The replacement Functional Resource Set concept is “lighter” – it is used as a mechanism for categorizing FRs that - singly or in sets – meet the requirements of a given Functional Resource stratum. The Functional Resource strata, in turn, are defined in broad terms and by the *service associations* that they support. A service association is essentially what was formally described by the Essential Port types.

Extensibility of the FR Reference Model

One of the key goals and concepts of the FR Ref Model is that it serves as the document that shows how FRs relate to each other to provide services. As new FRs are created, they will be

documented in the Ref Model, along with their relationships. They will be added to the Ref Model grouped according to the FR sets to which they belong, where an FR set can fulfill the role at a given FR stratum and therefore serve as a “plug-compatible” replacement for other sets in the same stratum.

The current set of FRs represented by Figure 2-2 covers the IOAG service Catalogue 1 services, for the most part. The most critical need is a set of CCSDS 415 FRs.

Clearly, we cannot keep expanding Fig. 2-2 to add new FRs. This is one place that the FR Strata concept will come in. These strata are already represented in Fig. 2-3. So while Fig 2-2 is currently useful (especially as the current baseline for specific relationships and cardinalities), it will eventually disappear, and the individual FRs will show up only in the diagrams in the later sections of the book.

Adjustments to FR names

The development of the SANA FR registry has led to some normalization of some of the FR names and abbreviations (which are formally called the FR *classifiers*). Some of those FR names in need of changing are flagged in this draft, but there is no promise of completeness. A cross-check against the candidate SANA FR registry should be performed, and the names and classifiers in this Tech Note should be brought into line with those names/classifiers.

One known discrepancy is the TC Synchronization and Channel Encoding FR, which has been normalized in the candidate SANA registry as Forward TC Synchronization and Channel Encoding. That change should be applied to throughout this Tech Note. Also, the TC Synchronization and Channel Encoding (now) Functional Resource Set should be similarly corrected,

Pre-validated Radiometric Data Collection/Data Store have been changed to “Non-validated Radiometric” to avoid the ambiguities associated with “pre-validated” – i.e., does it mean “before validation has occurred” (the intended meaning) or “it has already been validated” (another valid interpretation)?

Functional Resource Relationships and Cardinalities

Over time, many small details have been refined with regard to how the FRs relate to each other, and the cardinality of those relationships. The most accurate representation of those relationships/cardinalities is represented by Figure 2-2. Unless otherwise noted, all diagrams showing subsets of FRs (e.g., the FRs used to provide the Forward CLTU service) should be consistent with the corresponding parts of Fig. 2-2 (unless and until, of course, the need for further corrections is discovered).

Removal of RUFT Elements

The IOAG has withdrawn the Return UnFramed Telemetry (RUFT) from the service catalog, and it likewise needs to be removed from the Ref Model because there is no expectation of

it's being re-introduced in the foreseeable future. If and when it ever gets added back, by IOAG (or CCSDS), it can be re-admitted to the Ref Model.

Service Agreement and Configuration Profile Information Entity Models

The current draft *Service Agreement and Information Entity Format Specification* White Book contains a lot of modeling material. A tentative decision has been made to move some of that modeling material to this Reference Model so that SA & CP book can focus more on specific configuration profiles and eliminate the “theory” of how to form an SA or CP. A copy of the affected sections of the SA & CP book have been added to this draft Tech Note. Undoubtedly some of the material will have to be moved around and indeed altered to conform to the new Functional Resource Strata/Set model.

Data Store FRs Related to TGFT

In the current FR Reference Model, we have different FR Data Store types associated with each IOAG service that uses (will use) TGFT, i.e., Forward CFDP-File, Forward PACKETS-File, Return CFDP-File, Return PACKETS-File, D-DOR Raw Data, Open Loop Data, and Validated Radiometric Data.

Triggered by the TGFT discussions in Cleveland, I have looked more closely at the TGFT material to try to understand the impact on FRs. To recap the relevant points about Colin's current concept TGFT (as I understand them):

1. The TGFT provider is the entity that pushes data to the TGFT user (there is some controversy as to whether a pull capability should also be supported)
2. TGFT specifies that the user create ***one*** directory (the “in-tray” directory) into which the provider pushes the data for all services use TGFT. Metadata within the XFDU contained within the file is used to further direct the contents of the file to the appropriate process/application on the user side.
3. The TGFT only specifies the requirement for the establishment of the user-side directory.

As far as the FR Ref Model is concerned, in TGFT terms the Provider CSSS (which is the scope of the FRs of the Ref Model) is the TGFT “user” for the Forward CFDP-File, Forward PACKETS-File service(s), since the Provider CSSS “uses” the file to do its work (i.e., relay to contents of the files across the space link). The Provider CSSS is TGFT “provider” for the Return CFDP-File, Return PACKETS-File, D-DOR Raw Data, Open Loop Data, and Validated Radiometric Data services.

First consider the Forward file services, for which the Provider CSSS serves as the TGFT User. My interpretation of the TGFT concept and draft white book is that there is ***one*** TGFT instance per Mission, and ***one*** data store that conforms to the “in-tray” requirements. So far, so good – a Mission can use Forward CFDP File service, Forward PACKETS File service or both, and in all cases will push the files containing the appropriately-formatted XFDUs into the Provider CSSS's in-tray directory for that Mission.

DRAFT TECHNICAL NOTE CONCERNING THE FUNCTIONAL RESOURCE REFERENCE MODEL

Now consider the various Return services, for which the Provider CSSS serves as the TGFT Provider and pushes the files to the Mission. As noted above, in the current FR Reference Model, we have different FR Data Store types associated with each IOAG service that uses (will use) TFGT. I am now thinking that instead of return IOAG service-specific data stores, there should be one single Return File Data Store, into which all of the various return IOAG services deposit their XFDU-payload files. Since each Return File Data Store instance corresponds to a specific Mission, any file that appears in the directory that is represented by that Return File Data Store instance will automatically be transferred by the TFGT instance for that Mission.

So the bottom line is that I am suggesting that we consider deleting all of the return-service-specific data stores used by TGFT and channel all of the files through the single Return File Data Store.

Alternatively, the individual File-Transfer-related Data Stores might be mapped into a single “real” directory. Clearly this needs more analysis and discussion.

General Concerns about Data Sinks and Data Stores

I’ve have general concerns about data sinks and what the various data store FRs physically relate to.

What started me thinking about this area was the notion that each TGFT instance could support multiple what I’ll call IOAG service types, e.g., return file and open loop data. In particular, the notion that all service-specific data is in the metadata in the XFDU-formatted file. That got me to wondering whether our FR model, which shows a separate Data Store for each service data type, is correct. Should we instead have just one data store in each direction, and assume that the data would (a) be routed to the appropriate process based on the encapsulated metadata (in the forward direction), and (b) be packaged appropriately and put into a single data store (in the return direction)? I started to pursue this line of thinking, and ran into two speed bumps (if not total roadblocks). The first was our old containment fan-in/fan-out problem: if we have one data store associated with multiple data flows, it can’t be contained by an FR associated with any single one of them. We can use the ancillary interface approach (that’s why it’s just a speedbump and not a roadblock).

The second speed bump is trying to figure with which FRs the configuration information necessary to package/unpackage the files would reside. E.g., if we have just the return space data link protocol (SDLP) stack and a data store, what FR logically performs the creation of a file of packets into an SFDU? Assigning that to the SDLP is inappropriate. But putting that kind of functionality on a single data store means that the functionality of the Return Data Store FR type will evolve over time, in order to add cognizance of new data file types. It would be nice if for each different file type (corresponding to a separate IOAG service type) there would be an FR type that represents what has to be configured to handle a single file type.

Second stream of thought: What’s the physical significance of a data store FR instance? If each data store FR instance is locked to a specific physical entity – e.g., a specific directory

DRAFT TECHNICAL NOTE CONCERNING THE FUNCTIONAL RESOURCE REFERENCE
MODEL

on a specific server – then each configuration profile that contains data store FRs would in many cases be locked to a single site. So I’m thinking that the data store FRs have to be “virtual” enough that they specify usage parameters only, and are mapped onto physical servers through the scheduling process. I’m thinking along the lines of the Service Agreement containing the maximum set of data store FR instances that the Mission might be permitted to use, and for each Data Store FR instance, the mapping to each site (ESLT) that might be used to support that Mission. E.g., when a Service Package is scheduled on NASA Near Earth Network ESLT XYZ, the directory that realizes Forward File Data Store FR instance X is [https:// <xyz>.nen.nasa.gov/ffds/](https://<xyz>.nen.nasa.gov/ffds/). [I think a similar approach will be used for mapping the antenna FRs and TS/CSTS Provider FRs to individual ESLTs].

Third string of thought: we’ve got data sink FR types for some data flows but not all. We need to crystallize what the data sinks do and why they are needed in addition to the data stores themselves, or if we can’t justify their separate existence, kill them. But if they ***are*** useful, do we need some where they don’t exist today?

DOCUMENT CONTROL

Document	Title and Issue	Date	Status
CSSA- CSS_FRs- TN-0.1	Functional Resources in Cross Support Services, Issue 0.1	April 2013	first draft. Integrates FR material from multiple sources.
CSSA 1-TN- 0.2	Functional Resources in Cross Support Services, Issue 0.2	May 2013	<ul style="list-style-type: none">- Combines All Frames Reception with Return Sync and Decoding- Changes cardinality of symbol streams per subcarrier.- Changes Section to be a description of additional Function Resource Concepts, deletes the concept of Functional Resources Class.- Includes a new section 3, which describes Space Communication Cross Support Functional Groups.- Defines the FR Types needed for IOAG SC1 services, organized by Functional Group (section 4).- Includes a new section 5 that describes service templates and service profiles.

DRAFT TECHNICAL NOTE CONCERNING THE FUNCTIONAL RESOURCE REFERENCE
MODEL

CSSA 1-TN-0.3	Functional Resources in Cross Support Services, Issue 0.3	March 2014	<ul style="list-style-type: none">- Fixes various diagram errors- Responds to W. Hell comments on sections 1 through 4, and discussions at the San Antonio meetings.
CSSA 1-TN-0.4	Functional Resources in Cross Support Services, Issue 0.4	August 2014	<ul style="list-style-type: none">- Updates in response to comments at Noordwijkerhout meetings- Functional Resource adjustments in response to comments from W. Hell and A. Crowson- Terminology adjustments in response to ESCCS-SM Concept Green Book CESH review.- Abstract Service Component adjustments in response to ESCCS-SM Concept Green Book CESH review

DRAFT TECHNICAL NOTE CONCERNING THE FUNCTIONAL RESOURCE REFERENCE
MODEL

CSSA 1-TN-0.5	Functional Resources in Cross Support Services, Issue 0.5	March 2015	<ul style="list-style-type: none">- Updated master Functional Resource diagram concerning interactions of CDFP Entities with each other and other FRs- Changes names of SCs and FRs associated with Validated RM data service for clarity- Updated master FR diagram to properly identify sources of CLCWs.- Updated master FR diagram to adjust cardinalities- Split OIAG serviced into sub-services that align with the 3 service configurations: SLS, retrieval, and forward offline.- Removed the FRs in Service Management section to a separate Tech Note.
CSSA 1-TN-0.6	Functional Resources in Cross Support Services, Issue 0.6	April 2015	<ul style="list-style-type: none">- Applied normative FR type OIDs to all FR types.- Fixes numerous naming errors and inconsistencies.

DRAFT TECHNICAL NOTE CONCERNING THE FUNCTIONAL RESOURCE REFERENCE
MODEL

CSSA 1-TN- 0.7	Functional Resource and Service Component Reference Model, Issue 0.7	September 2015	<ul style="list-style-type: none">- Changed name reflect extended scope- Combined material from the <i>Service Components in Service Profiles</i> Tech Note- Re-organized and consolidated material to eliminate redundancies and provide a progressively-detailed exposure of the elements of the Reference Model.- Updated the details of the Functional Resources to reflect the latest concepts for and definitions of them.
CSSA 1-TN- 0.8	Functional Resource and Service Component Reference Model, Issue 0.8	September 2015	<ul style="list-style-type: none">- Adds annex with future SCs.
CSSA 1-TN- 0.9	Functional Resource and Service Component Reference Model, Issue 0.9	October 2015	<ul style="list-style-type: none">- Typo fixes- -Adds ports for frequency coherence and frequency offset relationships between forward and return space link carriers

DRAFT TECHNICAL NOTE CONCERNING THE FUNCTIONAL RESOURCE REFERENCE
MODEL

CSSA 1-TN- 0.10	Functional Resource Reference Model, Issue 0.10	July 2016	<ul style="list-style-type: none">- Drops “and Service Component” from the title- Downgrades the Abstract Service Components and Service Components from pseudo-operational entities (e.g., ones that have their own instances) to a concept for packaging sets of functional resources- Divides the previous “port” concept into two new concepts: SAP/Accessors and provided/required interfaces.- Move Service Agreement and Configuration Profile models here.
CSSA 1-TN- 0.11	Functional Resource Reference Model, Issue 0.11	July 2016	<ul style="list-style-type: none">- Modifies master functional resource diagram (figure 2-2) to move Forward Frames CSTS Provider to right side of diagram for consistency as a TS provider.

CONTENTS

<u>Section</u>	<u>Page</u>
BOOK CAPTAIN'S NOTES	I
DOCUMENT CONTROL	VI
CONTENTS	XI
1 INTRODUCTION	1-1
1.1 PURPOSE OF THIS REPORT	1-1
1.2 BACKGROUND	1-1
1.3 SCOPE	1-2
1.4 DOCUMENT ORGANIZATION	1-2
1.5 DEFINITIONS	1-3
1.6 REFERENCES	1-3
2 REFERENCE MODEL CONCEPTS.....	2-1
2.1 FUNCTIONAL RESOURCES.....	2-1
2.2 FUNCTIONAL RESOURCE STRATIFIED MODEL.....	2-5
2.3 FUNCTIONAL RESOURCE SETS.....	2-2
2.4 PORT PAIRS.....	2-5
2.5 SERVICE CONFIGURATION CATEGORIES.....	2-6
2.5.1 SLS CONFIGURATION CATEGORY	2-7
2.5.2 RETRIEVAL CONFIGURATION CATEGORY	2-11
2.5.3 FORWARD OFFLINE DATA DELIVERY CONFIGURATION	2-13
2.6 SERVICE PROFILES	2-14
2.7 SERVICE COMPONENT-BASED INFORMATION ENTITIES	2-17
2.7.1 SERVICE COMPONENT AGREEMENT	2-17
2.7.2 SERVICE COMPONENT PROFILE.....	2-17
2.7.3 SPACE COMMUNICATION SERVICE PROFILE	2-17
2.7.4 SERVICE AGREEMENT	2-17
2.7.5 CONFIGURATION PROFILE	2-18
3 FUNCTIONAL RESOURCE SETS, SERVICE ASSOCIATION ROLES, AND PROVIDED/REQUIRED INTERFACES.....	3-1
3.1 FUNCTIONAL RESOURCE SETS OF THE APERTURE STRATUM.....	3-1
3.2 SPECIALIZATIONS OF THE FORWARD PHYSICAL CHANNEL TRANSMISSION ASC	3-1
3.3 SPECIALIZATIONS OF THE FORWARD SYNC AND CHANNEL ENCODING ASC.....	3-2
3.4 SPECIALIZATIONS OF THE FORWARD SPACE LINK PROTOCOL TRANSMISSION ASC	3-3
3.5 SPECIALIZATIONS OF THE RETURN PHYSICAL CHANNEL RECEPTION ASC.....	3-3
3.6 SPECIALIZATIONS OF THE RETURN SYNC AND CHANNEL DECODING ASC.....	3-4
3.7 SPECIALIZATIONS OF THE RETURN SPACE LINK PROTOCOL RECEPTION ASC.....	3-4
3.8 SPECIALIZATIONS OF THE SLS DATA DELIVERY PRODUCTION ASC ..	3-5

3.9	SPECIALIZATIONS OF THE SLS RADIOMETRIC DATA PRODUCTION ASC	3-6
3.10	SPECIALIZATIONS OF THE OFFLINE DATA STORAGE PRODUCTION ASC	3-6
3.11	SPECIALIZATIONS OF THE DATA TRANSFER SERVICES ASC	3-7
4	FUNCTIONAL RESOURCE TYPES FOR FUNCTIONAL RESOURCE SETS	4-0
4.1	APERTURE FUNCTIONAL RESOURCE STRATUM	4-0
4.1.1	RF APERTURE FUNCTIONAL RESOURCE SET OF THE APERTURE FUNCTIONAL RESOURCE STRATUM	4-1
4.2	FORWARD PHYSICAL CHANNEL ABSTRACT SERVICE COMPONENT	4-2
4.2.1	CCSDS 401 FORWARD PHYSICAL CHANNEL TRANSMISSION SC SPECIALIZATION OF THE FORWARD PHYSICAL CHANNEL ABSTRACT SERVICE COMPONENT	4-2
4.3	FORWARD SYNCHRONIZATION AND CHANNEL ENCODING ASC	4-3
4.3.1	FORWARD TC SYNCHRONIZATION AND CHANNEL ENCODING SC SPECIALIZATION OF THE FORWARD SYNCHRONIZATION AND CHANNEL ENCODING ASC	4-4
4.3.2	FORWARD AOS SYNCHRONIZATION AND CHANNEL ENCODING SC SPECIALIZATION OF THE FORWARD SYNCHRONIZATION AND CHANNEL ENCODING ASC	4-5
4.4	FORWARD SPACE LINK PROTOCOL ASC	4-6
4.4.1	TC SPACE LINK PROTOCOL SPECIALIZATION OF THE FORWARD SPACE LINK PROTOCOL ASC	4-6
4.4.2	FORWARD AOS SPACE LINK PROTOCOL SPECIALIZATION OF THE FORWARD SPACE LINK PROTOCOL ASC	4-9
4.5	RETURN PHYSICAL CHANNEL RECEPTION ASC	4-10
4.5.1	CCSDS 401 RETURN PHYSICAL CHANNEL RECEPTION SC SPECIALIZATION OF THE RETURN PHYSICAL CHANNEL RECEPTION ASC	4-11
4.6	RETURN SYNCHRONIZATION AND CHANNEL DECODING ASC	4-12
4.6.1	RETURN TM SYNCHRONIZATION AND CHANNEL DECODING SC SPECIALIZATION OF THE RETURN SYNCHRONIZATION AND CHANNEL DECODING ASC	4-13
4.6.2	TELEMETRY SEGMENTER SC SPECIALIZATION OF THE RETURN SYNCHRONIZATION AND CHANNEL DECODING ASC	4-14
4.7	RETURN SPACE LINK PROTOCOL RECEPTION ASC	4-14
4.7.1	RETURN TM/AOS SPACE LINK PROTOCOL RECEPTION SPECIALIZATION OF THE RETURN SPACE LINK PROTOCOL ASC	4-15
4.8	SLS DATA DELIVERY PRODUCTION ASC	4-16
4.8.1	FRAME DATA SINK SC SPECIALIZATION OF THE SLS DATA DELIVERY PRODUCTION ASC	4-17
4.8.2	TELEMETRY SEGMENT SINK SC SPECIALIZATION OF THE SLS DATA DELIVERY PRODUCTION ASC	4-18
4.8.3	FORWARD FILE DATA DELIVERY PRODUCTION SC SPECIALIZATION OF THE SLS DATA DELIVERY PRODUCTION ASC	4-19
4.8.4	RETURN FILE SC SPECIALIZATION OF THE SLS DATA DELIVERY PRODUCTION ASC	4-20

DRAFT TECHNICAL NOTE CONCERNING THE FUNCTIONAL RESOURCE REFERENCE
MODEL

4.9	SLS RADIOMETRIC DATA PRODUCTION ASC	4-21
4.9.1	REAL-TIME RADIOMETRIC DATA COLLECTION SC SPECIALIZATION OF THE SLS RADIOMETRIC DATA PRODUCTION ASC	4-22
4.9.2	NON-VALIDATED RADIOMETRIC DATA COLLECTION SC SPECIALIZATION OF THE SLS RADIOMETRIC DATA PRODUCTION ASC	4-23
4.9.3	DELTA-DOR RAW DATA COLLECTION SC SPECIALIZATION OF THE SLS RADIOMETRIC DATA PRODUCTION ASC	4-24
4.9.4	OPEN LOOP RECEIVER/FORMATTER SC SPECIALIZATION OF THE SLS RADIO METRIC DATA PRODUCTION ASC	4-24
4.10	OFFLINE DATA STORAGE ASC	4-25
4.10.1	OFFLINE FRAME BUFFER SC SPECIALIZATION OF THE OFFLINE DATA DELIVERY PRODUCTION ASC	4-26
4.10.2	TELEMETRY SEGMENT RECORDING BUFFER SC SPECIALIZATION OF THE OFFLINE DATA STORAGE ASC	4-27
4.10.3	FORWARD FILE DATA STORE SC SPECIALIZATION OF THE OFFLINE DATA STORAGE ASC	4-27
4.10.4	RETURN FILE DATA STORE SC SPECIALIZATION OF THE OFFLINE DATA STORAGE ASC	4-28
4.10.5	TRACKING DATA MESSAGE (TDM) RECORDING BUFFER SC SPECIALIZATION OF THE OFFLINE DATA STORAGE ASC	4-29
4.10.6	NON-VALIDATED RADIOMETRIC DATA STORE SC SPECIALIZATION OF THE OFFLINE DATA STORAGE ASC	4-29
4.10.7	VALIDATED RADIOMETRIC DATA STORE SC SPECIALIZATION OF THE OFFLINE DATA STORAGE ASC	4-30
4.10.8	D-DOR RAW DATA STORE SC SPECIALIZATION OF THE OFFLINE DATA STORAGE ASC	4-31
4.10.9	OPEN LOOP DATA STORE SC SPECIALIZATION OF THE OFFLINE DATA STORAGE ASC	4-31
4.11	DATA TRANSFER SERVICES ASC	4-32
4.11.1	SLE FORWARD SPACE PACKET SPECIALIZATION OF THE DATA TRANSFER SERVICES ASC	4-33
4.11.2	SLE FORWARD CLTU SC SPECIALIZATION OF THE DATA TRANSFER SERVICES ASC	4-34
4.11.3	FORWARD FRAMES CSTS SC SPECIALIZATION OF THE DATA TRANSFER SERVICES ASC	4-34
4.11.4	TERRESTRIAL FILE TRANSFER SC SPECIALIZATION OF THE DATA TRANSFER SERVICES ASC	4-35
4.11.5	SLE RETURN ALL FRAMES SC SPECIALIZATION OF THE DATA TRANSFER SERVICES ASC	4-35
4.11.6	SLE RETURN CHANNEL FRAMES SC SPECIALIZATION OF THE DATA TRANSFER SERVICES ASC	4-36
4.11.7	SLE RETURN OPERATIONAL CONTROL FIELDS SC SPECIALIZATION OF THE DATA TRANSFER SERVICES ASC	4-37

DRAFT TECHNICAL NOTE CONCERNING THE FUNCTIONAL RESOURCE REFERENCE
MODEL

4.11.8	RETURN UNFRAMED TELEMETRY SC SPECIALIZATION OF THE DATA TRANSFER SERVICES ASC	4-37
4.11.9	TRACKING DATA CSTS SC SPECIALIZATION OF THE DATA TRANSFER SERVICES ASC	4-38
4.12	SERVICE MANAGEMENT FUNCTIONS ABSTRACT SERVICE COMPONENT	4-39
4.12.1	MONITORED DATA SPECIALIZATION OF THE SERVICE MANAGEMENT FUNCITONS ASC	4-39
4.12.2	SERVICE CONTROL SPECIALIZATION OF THE SERVICE MANAGEMENT FUNCTIONS ASC	4-40
4.13	SPACE INTERNETWORKING ABSTRACT SERVICE COMPONENT	4-41
4.13.1	IP OVER CCSDS SPECIALIZATION OF THE SPACE INTERNETWORKING ABSTRACT SERVICE COMPONENT	4-41
5	SERVICE PROFILES FOR SERVICES IN SLS CONFIGURATIONS.....	5-1
5.1	FORWARD DATA DELIVERY SERVICES	5-5
5.1.1	FORWARD CLTU SERVICE	5-5
5.1.2	FORWARD SPACE PACKET SERVICE.....	5-8
5.1.3	FORWARD FRAMES SERVICE.....	5-11
5.1.4	SLS FORWARD FILE TRANSMISSION SERVICE.....	5-14
5.2	RETURN DATA DELIVERY SERVICES	5-18
5.2.1	SLS RETURN ALL FRAMES SERVICE	5-18
5.2.2	RETURN FRAME CAPTURE SERVICE.....	5-20
5.2.3	SLS RETURN CHANNEL FRAMES SERVICE.....	5-21
5.2.4	RETURN OPERATIONAL CONTROL FIELDS SERVICE	5-22
5.2.5	SLS RETURN UNFRAMED TELEMETRY SERVICE.....	5-23
5.2.6	TELEMETRY SEGMENT CAPTURE SERVICE.....	5-25
5.2.7	RETURN FILE CAPTURE SERVICE	5-26
5.3	RADIOMETRIC SERVICES.....	5-29
5.3.1	PRE-VALIDATED RADIOMETRIC DATA CAPTURE SERVICE.....	5-29
5.3.2	SLS RAW RADIOMETRIC DATA SERVICE.....	5-34
5.3.3	TDM SEGMENT CAPTURE SERVICE.....	5-38
5.3.4	DELTA-DOR RADIOMETRIC DATA CAPTURE SERVICE.....	5-42
5.3.5	OPEN LOOP DATA CAPTURE SERVICE	5-43
6	SERVICE PROFILES FOR SERVICES IN RETRIEVAL CONFIGURATIONS	6-1
6.1	RETURN DATA DELIVERY SERVICES	6-1
6.1.1	RETURN ALL FRAMES RETRIEVAL SERVICE.....	6-1
6.1.2	RETURN CHANNEL FRAMES RETRIEVAL SERVICE	6-2
6.1.3	RETURN UNFRAMED TELEMETRY RETRIEVAL SERVICE	6-3
6.1.4	RETURN FILE RETRIEVAL SERVICE	6-4
6.2	RADIOMETRIC SERVICES.....	6-5
6.2.1	VALIDATED RADIOMETRIC DATA RETRIEVAL SERVICE.....	6-5
6.2.2	RAW DATA RADIOMETRIC SERVICE	6-6
6.2.3	DELTA-DOR RADIOMETRIC DATA RETRIEVAL SERVICE.....	6-7
6.2.4	OPEN LOOP DATA RETRIEVALSERVICE	6-8
7	SERVICE PROFILES FOR SERVICES IN FORWARD OFFLINE CONFIGURATIONS	7-1

DRAFT TECHNICAL NOTE CONCERNING THE FUNCTIONAL RESOURCE REFERENCE
MODEL

7.1	FORWARD DATA DELIVERY SERVICES	7-1
7.1.1	FORWARD FILE OFFLINE DELIVERY SERVICE	7-1
8	SERVICE AGREEMENT INFORMATION ENTITY	8-2
8.1	GENERAL	8-2
8.2	SERVICE AGREEMENT INFORMATION ENTITY CONTENT/STRUCTURE	8-2
8.2.1	CLASS SERVICEAGREEMENTINFOENTITY	8-3
8.2.2	CLASS SERVICEAGREEMENTHEADER	8-4
8.2.3	CLASS SERVICEAGREEMENTCONTENTS	8-6
8.2.4	CLASS FUNCTIONALRESOURCEAGREEMENT	8-6
8.2.5	DATA TYPE CONFIGURATIONPARAMETER	8-8
9	CONFIGURATION PROFILE INFORMATION ENTITY	9-1
9.1	CONFIGURATION PROFILE INFORMATION ENTITY CONTENT/STRUCTURE	9-1
9.1.1	CLASS CONFIGURATIONPROFILEINFOENTITY	9-1
9.1.2	CLASS CONFIGURATIONPROFILEHEADER	9-3
9.1.3	CLASS CONFIGURATIONPROFILECONTENTS (ABSTRACT) ..	9-4
1.1.2	CLASS SPACELINKSESSIONPROFILE	9-1
1.1.3	CLASS APERTURE (ABSTRACT)	9-1
9.1.4	CLASS SLSRADIOMETRICDATAPRODUCTION (ABSTRACT) ..	9-2
9.1.5	CLASS RETURNOFFLINEDATASTORE (ABSTRACT)	9-3
9.1.6	CLASS ACCESSORSERVICECOMPONENT (ABSTRACT)	9-3
9.1.7	CLASS FORWARDOFFLINEPROFILE	9-3
9.1.8	CLASS FORWARDOFFLINEDATASTORE (ABSTRACT)	9-4
9.1.9	CLASS SERVICEMANAGEMENTFUNCTIONPROFILE	9-4
9.1.10	CLASS SERVICEMANAGEMENTFUNCTION (ABSTRACT)	9-5
9.1.11	CLASS FUNCTIONALRESOURCEPROFILE	9-5
9.1.12	CLASS SAP (ABSTRACT)	9-7
9.1.13	CLASS PROVIDEDINTERFACE (ABSTRACT)	9-7
9.1.14	CLASS REQUIREDINTERFACE (ABSTRACT)	9-9

<u>Figure</u>	<u>Page</u>
Figure 2-1: Notional Interfaces of the Generic Functional Resource Type.....	2-2
Figure 2-2: CCSDS Core Functional Resource Types	2-4
Figure 2-3: Functional Resource Strata for Earth-Space Link Terminals.....	2-0
Figure 2-4: Functional Resources Sets within the Strata.....	2-4
Figure 2-5: Functional Resource Strata Used in SLS Configurations	2-8
Figure 2-6: Connectivity of Functional Resource Sets in SLS Configurations	2-9
Figure 2-7: Functional Resource Types Used in SLS Configurations	2-10
Figure 2-8: Functional Resource Strata Used in Retrieval Configurations	2-11

Figure 2-9: **Connectivity of Functional Resource Sets in Retrieval Configurations** 2-12

Figure 2-10: **Functional Resource Types Used in Retrieval Configurations**..... 2-13

Figure 2-11: **Functional Resource Strata Used in Forward Offline Data Delivery Configurations**..... 2-13

Figure 2-12: **Functional Resource Types Used in Forward Offline Data Delivery Configurations**..... 2-14

Figure 2-13: Functional Resource Sets Used in Forward CLTU SLS Configuration 2-15

Figure 2-14: **Functional Resource Types of the Forward CLTU Forward Data Delivery Service** 2-16

Figure 4-1: Internal Composition of the RF Aperture Functional Resource Set 4-1

Figure 4-2: Internal Composition of the CCSDS 401 Forward Physical Channel Transmission Service Component..... 4-3

Figure 4-3: Internal Composition of the TC Synchronization and Channel Encoding Service Component 4-4

Figure 4-4: Internal Composition of the AOS Synchronization and Channel Encoding Service Component..... 4-5

Figure 4-5: Internal Composition of the TC Space Link Protocol Transmission Service Component 4-7

Figure 4-6: Internal Composition of the Forward AOS Space Link Protocol Transmission Service Component..... 4-9

Figure 4-7: Internal Composition of the CCSDS 401 Return Physical Channel Reception Service Component..... 4-12

Figure 4-8: Internal Composition of the Return TM Synchronization and Channel Decoding Service Component..... 4-13

Figure 4-9: Internal Composition of the Telemetry Segmenter Service Component. 4-14

Figure 4-10: Internal Composition of the Return TM/AOS Space Link Protocol Reception Service Component..... 4-15

Figure 4-11: Internal Composition of the Frame Data Sink Service Component 4-17

Figure 4-12: Internal Composition of the Telemetry Segment Sink Service Component 4-18

Figure 4-13: Internal Composition of the Forward File Data Delivery Production Service Component	4-19
Figure 4-14: Internal Composition of the Return File Data Delivery Production Service Component	4-20
Figure 4-15: Internal Composition of the Real-Time Radiometric Data Collection Service Component	4-22
Figure 4-16: Internal Composition of the Non-validated Radiometric Data Collection Service Component	4-23
Figure 4-17: Internal Composition of the Delta-DOR Raw Data Collection Service Component	4-24
Figure 4-18: Internal Composition of the Open Loop Receiver/Formatter Service Component	4-25
Figure 4-19: Internal Composition of the Offline Frame Buffer Service Component	4-26
Figure 4-20: Internal Composition of the Telemetry Segment Recording Buffer Service Component	4-27
Figure 4-21: Internal Composition of the Forward File Data Store Service Component	4-28
Figure 4-22: Internal Composition of the Return File Data Store Service Component	4-28
Figure 4-23: Internal Composition of the TDM Recording Buffer Service Component	4-29
Figure 4-24: Internal Composition of the Non-validated Radiometric Data Store Service Component	4-30
Figure 4-25: Internal Composition of the Validated Radiometric Data Store Service Component	4-30
Figure 4-26: Internal Composition of the D-DOR Raw Data Store Service Component	4-31
Figure 4-27: Internal Composition of the Open Loop Data Store Service Component	4-32
Figure 4-28: Internal Composition of the SLE Forward Space Packet Service Component	4-33
Figure 4-29: Internal Composition of the SLE Forward CLTU Service Component	4-34

Figure 4-30: Internal Composition of the Forward Frames CSTS Service Component 4-34

Figure 4-31: Internal Composition of the Terrestrial File Transfer Service Component 4-35

Figure 4-32: Internal Composition of the Return All Frames Service Component ... 4-36

Figure 4-33: Internal Composition of the Return Channel Frames Service Component 4-36

Figure 4-34: Internal Composition of the Return Operational Control Fields Service Component 4-37

Figure 4-35: Internal Composition of the Return Unframed Telemetry Service Component 4-38

Figure 4-36: Internal Composition of the Tracking Data CSTS Service Component 4-38

Figure 4-37: Internal Composition of the Monitored Data Service Component 4-39

Figure 4-38: Internal Composition of the Service Control Service Component 4-40

Figure 4-39: Internal Composition of the IP over CCSDS Service Component 4-41

Figure 5-1: SCs Used in Forward CLTU Service 5-6

Figure 5-2: SCs Used in Forward Space Packet Service 5-9

Figure 5-3: SCs Used in Forward Frame Service 5-12

Figure 5-4: SCs Used in SLS Forward File Transmission Service 5-16

Figure 5-5: SCs Used in SLS Return All Frames Service 5-19

Figure 5-6: SCs Used in Return Frame Capture Service 5-20

Figure 5-7: SCs Used in SLS Return Channel Frames Service 5-22

Figure 5-8: SCs Used in ROCF Service 5-23

Figure 5-9: SCs Used in SLS RUFT Service 5-24

Figure 5-10: SCs Used in TM Segment Capture Service 5-25

Figure 5-11: SCs Used in Return File Capture Service 5-27

Figure 5-12: SCs Used in Pre-validatedData Radiometric Data Capture Service 5-31

Figure 5-13: SCs Used in SLS Raw Radiometric Data Service 5-35

Figure 5-14: SCs Used in TDM Segment Capture Service 5-39

Figure 5-15: SCs Used in Delta-DOR Radiometric Data Capture Service..... 5-43

Figure 5-16: SCs Used in Open Loop Data Capture Service..... 5-44

Figure 6-1: SCs Used in Return All Frames Retrieval Service..... 6-2

Figure 6-2: SCs Used in Return Channel Frames Retrieval Service 6-3

Figure 6-3: SCs Used in Return Unframed Telemetry Retrieval Service..... 6-4

Figure 6-4: SCs Used in Return File Retrieval Service 6-5

Figure 6-5: SCs Used in Validated Radiometric Data Retrieval Service..... 6-6

Figure 6-6: SCs Used in Raw Radiometric Data Retrieval Service..... 6-7

Figure 6-7: SCs Used in Delta-DOR Radiometric Data Retrieval Service 6-8

Figure 6-8: SCs Used in Open Loop Data Retrieval Service 6-8

Figure 7-1: SCs Used in Forward File Offline Delivery Service..... 7-2

Figure 8-1: Service Agreement Information Entity Class Diagram 8-3

Figure 9-1: Configuration Profile Information Entity Class Diagram..... 9-1

Figure 2-2: Configuration Profile Contents Class Diagram 9-6

1 INTRODUCTION

AUTHOR'S NOTE -This section has not yet been reworked.

1.1 PURPOSE OF THIS REPORT

This report documents the elements of the Functional Resource and Service Component Reference Model and their use in the construction, scheduling and execution of cross support services.

1.2 BACKGROUND

The Functional Resource concept was originally developed as a way to provide unique qualifiers for monitored parameter names in cases where multiple instances of those parameters could be reported simultaneously through the Monitored Data CSTS (MD-CSTS). A strawman set of Functional Resource Types was developed for the MD-CSTS (see reference [10]). The strawman Functional Resource Types were subsequently used (with modifications) to generate a proposed standard set of monitored parameters for each functional resource type.

Fundamental to the concept of Functional Resources is that each one represents a cohesive, atomic set of space communication functionality with which can be associated single instances of management parameters, monitored parameters, real-time control parameters, and event notifications.

Functional Resources are not the physical resources (e.g., transmitters and receivers) that comprise real systems. Rather, they represent the functions or capabilities that are provided by those physical resources. A Functional Resource may be realized by several physical entities that work cooperatively to perform that function. Alternatively, for some types of functional resources, a single physical resource may be designed such that it instantiates several functional resources.

The concept has subsequently been adopted as a core concept of the *CSTS Specification Framework* (CSTS SFW) (see reference [4]), with standard parameter names being defined as having a functional resource identifier component. The CSTS SFW also defines a registration subtree for functional resource type Object Identifiers (OIDs) under the CCSDS registration tree. The technical note "Operational Scenario Implementation" (reference [11]) applied the functional resource type and monitored parameter OID structure to the proposed standard set of monitored parameters. Besides monitored parameters, the Functional Resource registration tree defined in the CSTS SFW is used to register OIDs for *notifiable events* and *directives* associated with each Functional Resource Type. *Notifiable events* are also reported by the MD-CSTS. A *directive* is a control action that is invoked in real time. The directives are intended for use by a future Service Control CSTS (and possible other CSTSes).

The Functional Resource concept has been adopted as the method for organizing the management information associated with the services to be managed via the in-progress *Space Communication Cross Support Service Management – Service Agreement and Configuration Profile Data Formats Recommended Standard* (see the *Extensible Space Communication Cross Support Service Management Concept Green Book*, reference [12]). However, for purposes of Service Management, Functional Resources are *too* granular – the prospect of managing all possible combinations at the individual Functional Resource level is overwhelming. Fortunately, from a real-world perspective, in many cases multiple Functional Resources are used to represent the functionality of a single technical specification (e.g., a CCSDS Recommended Standard) such that the associated set of Functional Resources can be treated as a unit. Such units are called *service components*.

1.3 SCOPE

The scope of this technical note is limited to the functional resources that are associated with what are called *Earth Space Link Terminals* (ESLTs) in the SCCS Architecture (reference [13]). As its name implies, an ESLT provides an Earth-side termination of a space-ground link to a *Space User Node* (spacecraft, rover, etc.). A typical ESLT is a ground station, but in the case of a relay satellite system in which both the ground terminal and the relay satellite belong to the same operational organization such that the operation of the links between the ground terminal and the relay satellite are not exposed to the user mission (such as the NASA Space Network), the ESLT represents the functionality of both the ground terminal *and* the relay satellite.

1.4 DOCUMENT ORGANIZATION

Section 2 provides an overview of the various conceptual building blocks of the Functional Resource and Service Components Reference Model.

Section 3 provides a “black box” view of the Abstract Service Components (ASCs) and the current set of Service Component (SC) specializations for each ASC..

Section 4 describes the Functional Resource Types that represent the functions that are performed by Earth Space Link Terminals (ESLTs). Primarily, these Functional Resource Types are the ones that represent the functions that are performed in providing IOAG Service Catalog 1 services.

Section 5 defines the Service Profiles for Space Link Session services (that is, services that are provided in conjunction with an operating space link). Each Service Profile is defined in terms of the ASCs and SCs that can be used to provide that service.

Section 6 defines the Service Profiles for Retrieval services (that is, services that allow the retrieval of data received by the ESLT via an operating space link). Each Service Profile is defined in terms of the ASCs and SCs that can be used to provide that service.

Section 7 defines the Service Profiles for Forward Offline services (that is, services that allow the placement of data at the ESLT for subsequent forwarding to the recipient via an operating space link). Each Service Profile is defined in terms of the ASCs and SCs that can be used to provide that service.

Section 1 identifies the Service Component-based Information Entities that are used by Service Management to create Service Agreements and Configuration Profiles. In this draft version, the section remains To Be Supplied (TBS).

1.5 DEFINITIONS

TBS.

1.6 REFERENCES

The following documents are referenced in this Report. At the time of publication, the editions indicated were valid. All documents are subject to revision, and users of this Report are encouraged to investigate the possibility of applying the most recent editions of the documents indicated below. The CCSDS Secretariat maintains a register of currently valid CCSDS documents.

- [1] *Cross Support Reference Model—Part 1: Space Link Extension Services*. Recommendation for Space Data System Standards, CCSDS 910.4-B-2. Blue Book. Issue 2. Washington, D.C.: CCSDS, October 2005.
- [2] *Space Link Extension—Return All Frames Service Specification*. Recommendation for Space Data System Standards, CCSDS 911.1-B-3. Blue Book. Issue 3. Washington, D.C.: CCSDS, January 2010.
- [3] *Space Link Extension—Return Channel Frames Service Specification*. Recommendation for Space Data System Standards, CCSDS 911.2-B-2. Blue Book. Issue 2. Washington, D.C.: CCSDS, January 2010.
- [4] *Cross Support Transfer Service - Specification Framework*, Draft Recommended Standard, CCSDS 921.1-R-2-draft. March 2014.
- [5] *TC Synchronization and Channel Coding*. Recommendation for Space Data System Standards, CCSDS 231.0-B-2. Blue Book. Issue 2. Washington, D.C.: CCSDS, September 2010.
- [6] *TM Synchronization and Channel Coding*. Recommendation for Space Data System Standards, CCSDS 131.0-B-2. Blue Book. Issue 2. Washington, D.C.: CCSDS, August 2011.
- [7] *Return Unframed Telemetry Cross Support Transfer Service*. Recommended Standard. CCSDS 922.?. (future)

DRAFT TECHNICAL NOTE CONCERNING THE FUNCTIONAL RESOURCE REFERENCE
MODEL

- [8] *Tracking Data Cross Support Transfer Service*. Draft Recommended Standard. CCSDS 922.2-W-0.6. March 2013.
- [9] *IOAG Service Catalog #1*. Issue 1, Revision 4. Interagency Operations Advisory Group. June 2013.
- [10] *Monitored Data Cross Support Transfer Service*. Draft Recommended Standard. CCSDS 922.1-W-0.12. February 2013.
- [11] Doat, Yves, “Operational Scenario Implementation”, CSTSWG technical note. 20 May 2012.
- [12] *Extensible Space Communication Cross Support Service Management Concept*. Draft Informational Report. CCSDS-902.0. Green Book. [in publication].
- [13] *Space Communications Cross Support Architecture Description Document*. Report Concerning Space Data System Standards, CCSDS 901.0-G-1. Green Book. Issue 1. Washington, D.C.: CCSDS, November 2013.
- [14] *Space Communication Cross Support - Service Management – Service Specification*. Recommendation for Space Data System Standards, CCSDS 910.11-B-1. Blue Book. Issue 1. Washington, D.C.: CCSDS, September 2009.
- [15] *Space Communication Cross Support Service Management – Service Agreement and Configuration Profile Data Formats*. Future Recommended Standard.
- [16] *IOAG Service Catalog #2*. IOAG.T.SC2.2011.V1.1. Issue 1, Revision 1. Interagency Operations Advisory Group. June 2013.
- [17] *TC Space Data Link Protocol*. Recommendation for Space Data System Standards, CCSDS 232.0-B-2. Blue Book. Issue 2. Washington, D.C.: CCSDS, September 2010.
- [18] *AOS Space Data Link Protocol*. Recommendation for Space Data System Standards, CCSDS 732.0-B-2. Blue Book. Issue 2. Washington, D.C.: CCSDS, July 2006.
- [19] *TM Space Data Link Protocol*. Recommendation for Space Data System Standards, CCSDS 132.0-B-1. Blue Book. Issue 1. Washington, D.C.: CCSDS, September 2003.
- [20] *Space Packet Protocol*. Recommendation for Space Data System Standards, CCSDS 133.0-B-1. Blue Book. Issue 1. Washington, D.C.: CCSDS, September 2003.
- [21] *Communications Operation Procedure-1*. Recommendation for Space Data System Standards, CCSDS 232.1-B-1. Blue Book. Issue 1. Washington, D.C.: CCSDS, September 2003.
- [22] *Encapsulation Service*. Recommendation for Space Data System Standards, CCSDS 133.1-B-2. Blue Book. Issue 2. Washington, D.C.: CCSDS, October 2009 (Cor. 1 September 2012).

DRAFT TECHNICAL NOTE CONCERNING THE FUNCTIONAL RESOURCE REFERENCE
MODEL

- [23] *Radio Frequency and Modulation Systems—Part 1: Earth Stations and Spacecraft*. Recommendation for Space Data System Standards, CCSDS 401.0-B-21. Blue Book. Issue 21. Washington, D.C.: CCSDS, July 2011.
- [24] *Pseudo-Noise (PN) Ranging Systems*. Recommendation for Space Data System Standards, CCSDS 414.1-B-1. Blue Book. Issue 1. Washington, D.C.: CCSDS, March 2009.
- [25] *Data Transmission and PN Ranging for 2 GHz CDMA Link via Data Relay Satellite*. Recommendation for Space Data System Standards, CCSDS 415.1-B-1. Blue Book. Issue 1. Washington, D.C.: CCSDS, September 2011.
- [26] *CCSDS File Delivery Protocol (CFDP)*. Recommendation for Space Data System Standards, CCSDS 727.0-B-4. Blue Book. Issue 4. Washington, D.C.: CCSDS, January 2007.
- [27] *Space Link Extension—Forward CLTU Service Specification*. Recommendation for Space Data System Standards, CCSDS 912.1-B-3. Blue Book. Issue 3. Washington, D.C.: CCSDS, July 2010.
- [28] *Space Link Extension—Forward Space Packet Service Specification* Recommendation for Space Data System Standards, CCSDS 912.3-B-2. Blue Book. Issue 2. Washington, D.C.: CCSDS, July 2010.
- [29] *Space Link Extension—Return Operational Control Fields Service Specification*. Recommendation for Space Data System Standards, CCSDS 911.5-B-2. Blue Book. Issue 2. Washington, D.C.: CCSDS, January 2010.
- [30] *Rationale, Scenarios, and Requirements for DTN in Space*. Report Concerning Space Data System Standards, CCSDS 734.0-G-1. Green Book. Issue 1. Washington, D.C.: CCSDS, August 2010.
- [31] *IP Over CCSDS Space Links*. Recommendation for Space Data System Standards, CCSDS 702.1-B-1. Blue Book. Issue 1. Washington, D.C.: CCSDS, September 2012.
- [32] *Delta-DOR Raw Data Exchange Format*. Recommendation for Space Data System Standards, CCSDS 506.1-B-1. Blue Book. Issue 1. Washington, D.C.: CCSDS, June 20013.

2 REFERENCE MODEL CONCEPTS

The Functional Resource Reference Model is built upon the concepts of:

- functional resources,
- functional resource strata model,
- functional resource sets,
- service association types,
- provided and required interfaces,
- service configuration categories, and
- service profiles.

These conceptual building blocks are combined and refined in various combinations to create the Service Management functional resource-based Information Entities:

- service agreement,
- service component profiles,
- space communication service profile,
- transfer service profile,
- retrieval service profile, and
- forward offline service profile.

This section describes the conceptual building blocks and the Service Component-based Information Entities.

2.1 FUNCTIONAL RESOURCES

Functional Resources are abstract representations of the functionality needed to provide space communication and navigation services, defined at a level of granularity sufficient to specify the configuration parameters, monitored parameters, and notifiable events associated with that functionality. Functional Resources exist to represent such information as it applies to a cross support interface – if a processing function does not have unique monitored parameters, notifiable events, or any configuration parameters that need to be set (possibly through configuration profiles), queried, or reconfigured(via real-time control directives), then it does not have a Functional Resource to represent it. Note that only one of these facets needs to be present in order for a function to need to be represented by a Functional Resource.

Figure 2-1 depicts a generic Functional Resource Type and its notional interfaces.

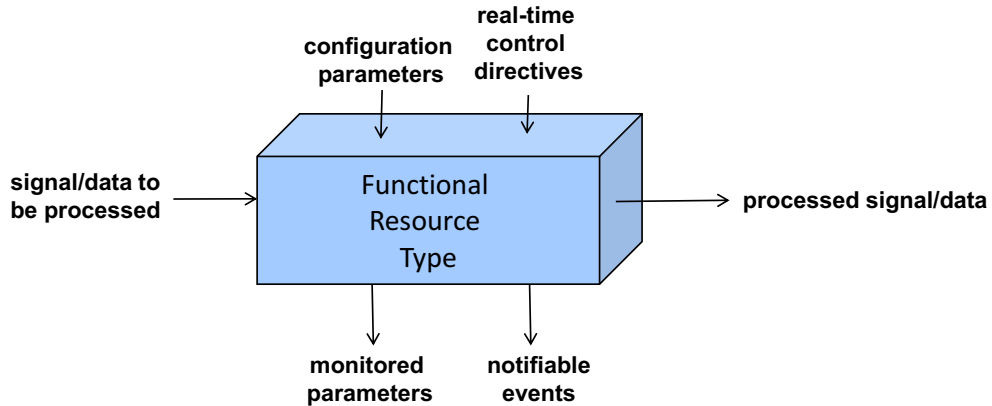

Figure 2-1: Notional Interfaces of the Generic Functional Resource Type

The horizontal interfaces represent the flow of data or a signal through an instance of the FR Type – the “function” of the FR Type is the process that it performs on this signal/data. Such processing can involve converting one type of signal to another type of signal, manipulating data to produce another type of data, generating signals from data, or extracting data from signals (e.g., space communication data modulated onto an electromagnetic carrier signal, or Doppler data derived from an electromagnetic carrier signal). An FR instance is configured via the setting of the configuration parameters for its FR Type. When the FR instance is active, it emits measurements of whatever monitored parameters are defined for that FR Type. The FR instance also emits event notifications if any of the notifiable events that are defined for its FR Type occur. Finally, the behavior of an FR instance may be modified via the real-time control directives that are defined for its FR Type (if any).

For the IOAG Service Catalog #1 services performed by an Earth Space Link Terminal (which is the current scope of SCCS-SM), the composite functionality includes the transmission/reception of the signal on the space link with the Space User Node, the channel synchronization and coding/decoding of the data on that space link, the execution of the space link protocols, and the provision of the cross support services by which the User missions submit data destined for their Space User Node and receive data from their Space User Node. This functionality nominally conforms to the specifications provided by CCSDS Recommended Standards for space link modulation (reference [23]), synchronization and channel coding (references [5] and [6]), space data link protocols (references [17] - [22]), terrestrial cross support services e.g., (references [2], [3], and [10]), and space internetworking services (references [30] and [31]).

The services provided in a Service Package can contain multiple instances of *Functional Resource Types* (FR Types). Each FR Type is assigned an ISO object identifier (OID). The FR Type OID is used to construct unique identifiers for functional resource instances and for the monitored parameters, configuration parameters, notifiable events, and real-time control directives that those functional resources expose for Service Management purposes. A Functional Resource instance is identified by its Functional Resource Name, which is the combination of the Functional Resource Type with a Functional Resource Instance Number

DRAFT TECHNICAL NOTE CONCERNING THE FUNCTIONAL RESOURCE REFERENCE
MODEL

(see the *Cross Support Transfer Service Specification Framework* (reference [4]) for additional details on the formal syntax of Functional Resource identifiers).

Figure 2-2 is a diagram of all CCSDS core functional resources that are used to implement the IOAG Service Catalog #1 services in Earth Space Link Terminals. The functional resources are color-coded to identify the Functional Resource strata to which they belong (see 2.2). Each of these functional resources is described in section 4.

DRAFT TECHNICAL NOTE CONCERNING THE FUNCTIONAL RESOURCE REFERENCE MODEL

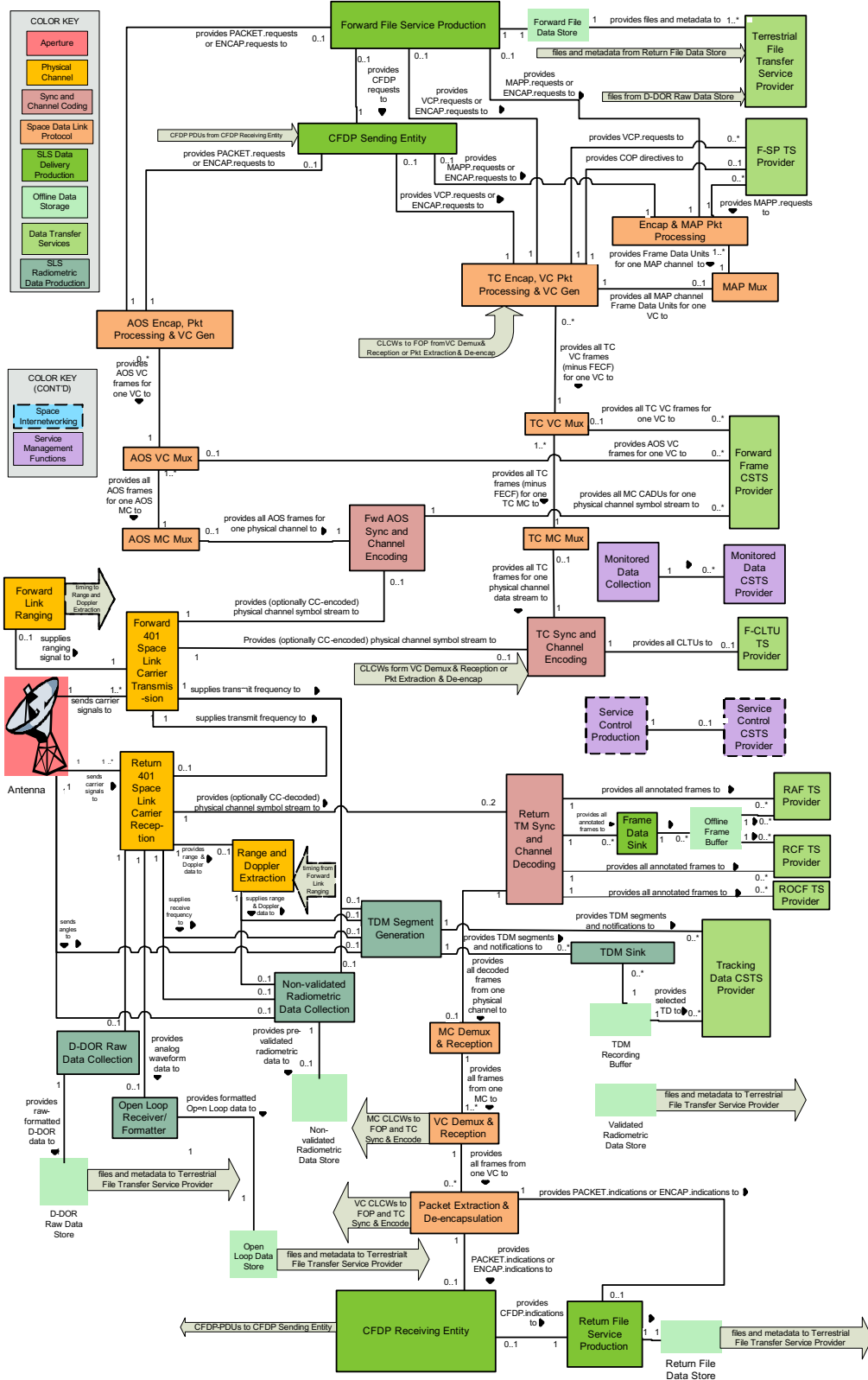

Figure 2-2: CCSDS Core Functional Resource Types

2.2 FUNCTIONAL RESOURCE STRATIFIED MODEL

NOTE - Parts of this section are adapted from material in the *Extensible Space Communication Cross Support Concept* Green Book (reference [12]). That Green Book uses the modeling and terminology of the SCCS Architecture Description Document Green Book (reference [13]). That SCCS ADD terminology is also used in this section. The translation between the SCCS ADD terms used in this section and the terms of the Cross Support Reference Model (reference [1]) is as follows:

- the *Earth Space Link Terminal* (ESLT) is part of the *SLE Complex*;
- the *Space User Node* is equivalent to the *Space Element* (i.e., mission spacecraft);
- the *Earth User Node* is part of the *MDOS*; and
- the *Provider* CSSS is equivalent to the *SLE Complex*.

Functional Resource Types represent specific space communication technologies and specific terrestrial cross support services. As space communication technologies evolve and new terrestrial cross support services are added over time, the FR Types that are used to represent them may need to be augmented or replaced by different FR Types. In cases where multiple FR Types are closely bound to a particular space communication technology (e.g., space link signal modulation), the replacement/addition of such a technology could involve the replacement/addition of multiple FR Types. Similarly, a terrestrial cross support service may need multiple FR Types to represent the total functionality associated with that cross support service. For example, a return offline SLE transfer services has an FR Type for the service provision functions of the SLE service, and also an FR Type for the offline buffer that stores the data for subsequent retrieval by the SLE service provider.

The concept of Abstract Service Components (ASCs) accommodates the bundling of related FR Types for the purposes of substitution and extensibility. Organizing the ASCs around space communication technology-related groupings that can be substituted or added is important for Extensible Space Communication Cross Support Service Management (ESCCS-SM) because such groupings identify the *extensibility points* for SCCS-SM information entities.

Basing the ASCs on a purely abstract layered model of space communication functionality ensures that any new space communication technology can be introduced into and supported by ESCCS-SM as long as it conforms to the minimal functional and interface definitions for the corresponding ASC. The abstract layered model has the following components:

- a. The aperture, which is the physical interface to the space medium. On the “ground side”, the aperture receives and/or transmits an electromagnetic carrier signal.
- b. The physical channel, which transfers a stream of channel bits through the aperture across the physical medium (in this case, space). In addition to the transfer of a stream of bits, the physical channel may also carry non-binary signals, e.g. for the purpose of range measurements. The space physical channel has traditionally been provided at radio frequencies using RF modulation techniques, but the use of optical physical channels is expected to increase.

DRAFT TECHNICAL NOTE CONCERNING THE FUNCTIONAL RESOURCE REFERENCE
MODEL

NOTE - In any realization of a space link, the technology used by the aperture must be compatible with the technology used by the physical channel. However, the possibility for multiple aperture technologies being applicable to the same physical channel technology (e.g., a single-feed steerable antenna, an array of geographically-separated steerable antennas, an array of fixed antenna elements that “point” by adjusting the phase differences among those antenna elements) justifies treating apertures separately from physical channels for the purposes of SCCS ASC definition.

- c. Channel synchronization and coding, which consists of the error coding, randomization, and synchronization functions that are performed to convert space data link transfer frames to the bit streams that are transferred across the space physical channel, and vice versa.
- d. Space data link protocols that insert/extract space-optimized protocol data units (PDUs) into/from space data link transfer frames and in some cases control the flow of those transfer frames across the space link.
- e. Data delivery transfer services that allow remote user mission entities to interface with the ESLT for the purpose of exchanging data with their respective Space User Node via the space links provided by the ESLT. These services include SLE Transfer Services, CSTSes, and application-level services that transform data on the way to or from the Space User Node.
- f. Offline data storage, used to hold data when the transfer of data to or from the Space User Node cannot occur at the same time (or at the same data rate) as that of the space link over which the data is to be transported.
- g. Internetworking protocols that provide end-to-end connectivity across multiple kinds of data links, including space links.

NOTE - Space Internetworking is part of IOAG Service Catalog #2 capabilities.

For the IOAG Service Catalog #1 services performed by an ESLT (which is the current scope of SCCS SM), the composite functionality of these abstract layers conforms to the specifications provided by CCSDS Recommended Standards for space link modulation (reference [23]), synchronization and channel coding (references [32] and [6]), space data link protocols (references [19], [18], and [17]), and terrestrial cross support transfer services (references [27], [2], [3], [29], and [28]). Over time, these Recommended Standards will be augmented to accommodate new space communications and tracking technologies (e.g., radio frequency vs. optical technologies at the aperture and physical channel layers). Each space communications technology may have its own set of management parameters that must be used when that technology is employed in the configuration of an ESLT. In SCCS SM, these abstract communication layers are represented by ASCs.

Figure 2-3 depicts the set of SCCS ASCs for the ESLT, and the possible data flows through them. As illustrated in the figure, many combinations of ASCs are possible, although most services will each use only a single flow through the ASCs.

NOTES

DRAFT TECHNICAL NOTE CONCERNING THE FUNCTIONAL RESOURCE REFERENCE
MODEL

- 1 The possible flows shown in Figure 2-3 are the space communications and radiometric service data flows through these ASCs. They do not include the flows by which these ASCs are configured and controlled in real time and by which monitored parameter values and event notifications are collected from the various ASCs for reporting to the Earth User Node. Such data flows can be considered to occur in a separate management dimension (see the paragraph describing the Service Management Functions ASC below).
- 2 Figure 2-3 includes a Space Internetworking ASC, even though space internetworking is an IOAG Service Catalog #2 capability and outside the current scope of this Informational Report. This ASC is included to illustrate how space internetworking can be accommodated within the ASC concept.
- 3 Although the set of ASCs identified in this Technical Note encompass all services of IOAG Service Catalogs 1 and 2, new SCCS services may be introduced in the future that do not easily fit into the ASCs defined herein. If that happens, new SCCS ASCs will be defined in a way that provides the same kinds of extensibility as the ASCs described in this Technical Note.

The IOAG services are distributed across multiple ASCs to align with the IOAG service categories defined in Service Catalogs #1 and #2 (references [9] and [16], respectively). IOAG services are categorized into *data delivery services* (forward and return), *radiometric services*, and *service management functions*. The data delivery and radiometric service groups are further divided into the *space link interfaces* and *ground link interfaces* of which they are composed.

The set of ASCs that correspond to the Space Link Interface Standards are the Aperture, Forward Physical Channel Transmission, Forward Synchronization and Channel Encoding, Forward Space Link Protocol Transmission, Return Physical Channel Reception, Return Synchronization and Channel Decoding, and/or Return Space Link Protocol Reception ASCs. By definition, these ASCs are present only in SLS configurations (see 2.5.1).

- The Aperture ASC represents the general class of apertures through which forward space link signals are transmitted and return space link signals are received as part of SLS Service Packages. Some apertures can be used by multiple forward and/or return space links simultaneously, although specific types may be limited in directionality and/or number of simultaneous links. With respect to the SCCS SM Enterprise Model functions, the Aperture ASC maps to the Space Link Processing function of the Provider CSSS.

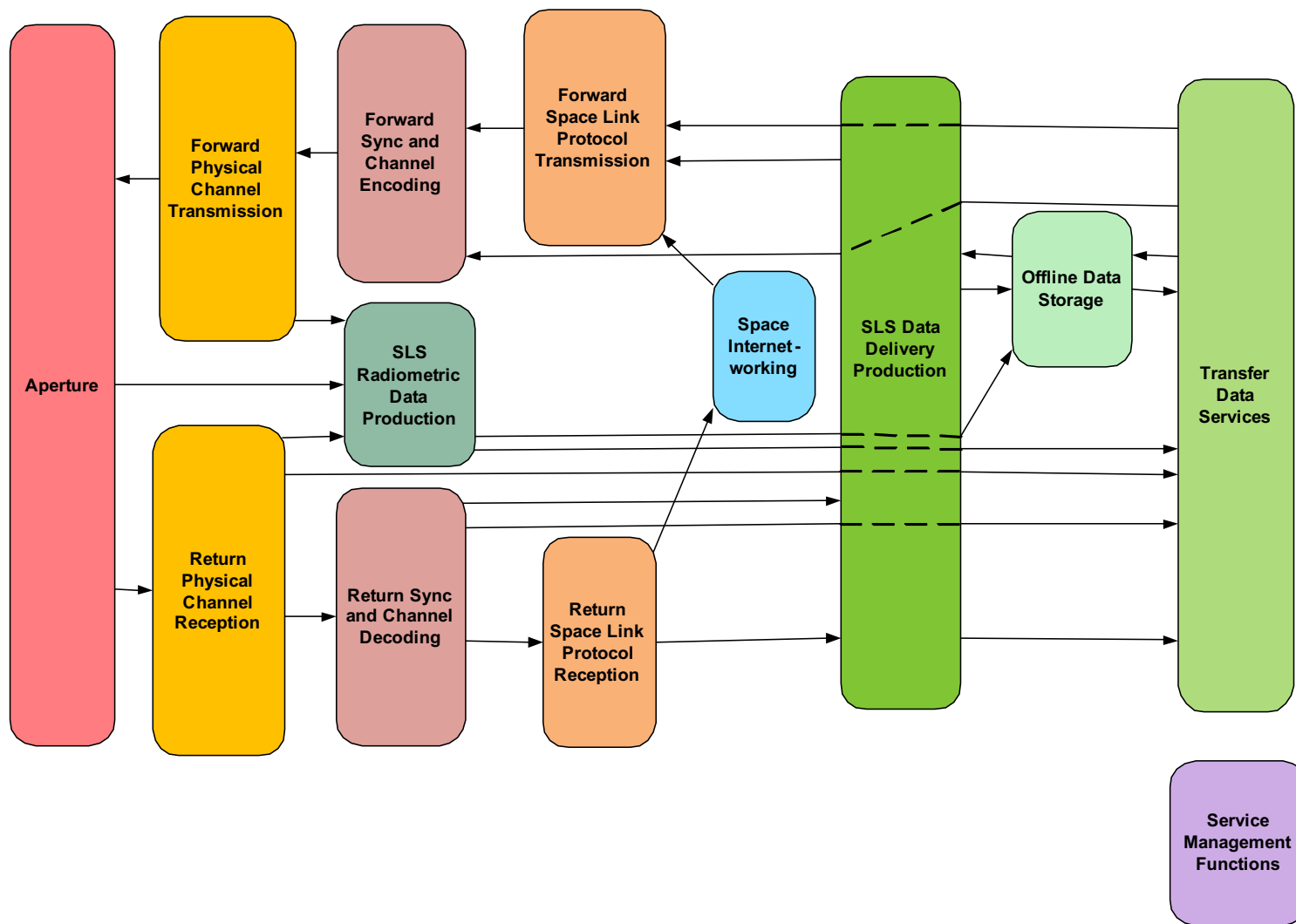

Figure 2-3: Functional Resource Strata for Earth-Space Link Terminals

DRAFT TECHNICAL NOTE CONCERNING THE FUNCTIONAL RESOURCE REFERENCE
MODEL

- The Forward Physical Channel Transmission and Return Physical Channel Reception ASCs represent the RF modulation, (future) optical modulation, and radiometric measurement functions that are performed as part of SLS Service Packages. With respect to the SCCS SM Enterprise Model functions, the Forward Physical Channel Transmission and Return Physical Channel Reception ASCs are part of the Space Link Processing function of the Provider CSSS.
- The Forward Synchronization and Channel Encoding and Return Synchronization and Channel Decoding ASCs represent the coding/decoding and synchronization functions that are performed as part of SLS Service Packages. With respect to the SCCS SM Enterprise Model functions, the Forward Synchronization and Channel Encoding and Return Synchronization and Channel Decoding ASCs map to the Space Link Processing function of the Provider CSSS.
- The Forward Space link Protocol Transmission and Return Space Link Reception ASCs represent the space link protocol processing functions that are performed as part of SLS Service Packages. With respect to the SCCS SM Enterprise Model functions, the Forward Space link Protocol Transmission and Return Space Link Reception ASCs map to the Space Link Processing function of the Provider CSSS.

The set of ASCs that correspond to the ground link interfaces of the IOAG data delivery and radiometric services are the SLS Data Delivery Production ASC, the SLS Radiometric Data Production ASC, the Offline Data Storage ASC, the Data Transfer Services ASC, and the Space Internetworking ASC.

- The SLS Data Delivery Production ASC represents the additional production functions beyond those provided by the Aperture, Physical Channel, Synchronization and Channel Coding, and/or Space Link Protocol ASCs that are performed as part of SLS Service Packages. For forward link data, the SLS Data Delivery Production ASC functions provide the additional processing needed to transmit data that is either transferred in real time via a Data Delivery transfer service or extracted from intermediate storage. For return link data, the SLS Data Delivery Production ASC functions provide the additional processing needed to prepare the data for either intermediate storage and/or real-time delivery via a Data Transfer service. With respect to the SCCS SM Enterprise Model functions, the SLS Data Delivery Production ASC maps to the Data Forwarding function of the Provider CSSS.
- The SLS Radiometric Data Production ASC represents the additional production functions (beyond the Aperture and Physical Channel ASC radiometric measurement functions) that are performed as part of SLS Service Packages in order to prepare radiometric data for intermediate storage and/or real-time delivery via a Radiometric Data transfer service. With respect to the SCCS SM Enterprise Model functions, the SLS Radiometric Data Production ASC maps to the Application Service function of the Provider CSSS.
- The Offline Data Storage ASC represents the production functions that are performed as part of Retrieval Service Packages (for return link communication and radiometric

- data) or a Store and Forward Service Package (for forward link communication data). For return link data, these functions include (but are not necessarily limited to) the data stores and recording buffers that hold data awaiting subsequent retrieval. For forward link data, these functions include (but are not necessarily limited to) the data stores that hold data awaiting subsequent transmission during a space link session. With respect to the SCCS Enterprise Model functions, the Offline Data Delivery Production ASC maps to the Data Store and the Data Forwarding functions of the Provider CSSS.
- The Data Transfer Services ASC represents the various cross-support transfer services that are used to transfer space link communication data and radiometric data across terrestrial networks between a spaceflight Mission ground facility and an ESLT. These services include the SLE transfer services, CSTS that transfer communication data to be sent or that has been received through the space link, services that transfer radiometric data from the ESLT to the Mission ground facility, as well as services that transfer files of communication data that is to be sent or that has been received through the space link. With respect to the SCCS SM Enterprise Model functions, the Data Transfer Services ASC maps to the Data Forwarding function of the Provider CSSS.
 - The Space Internetworking ASC represents functions performed to transfer internetwork data across the space link as part of an end-to-end internetwork data transfer. IOAG Service Catalog #1 (reference [9]) does not include internetwork services; those are covered by Service Catalog #2 (reference [16]). These ASCs are included in the set of ESLT ASCs for completeness.

The Service Management Functions ASC corresponds to the IOAG service management functions. There are two transfer services that belong to the Service Management Functions ASC: the MD-CSTS and the future SC-CSTS. As noted above, the Service Management Functions interface with all of the other ASCs via connections that exist in a management dimension that is not illustrated in **Error! Reference source not found.** With respect to the SCCS SM Enterprise Model functions, the Service Management Functions ASC maps to the Application Service function of the Provider CSSS.

The ASCs do not have specific management parameters, monitored parameters, notifiable events and real-time control parameters. An ASC must be specialized to a concrete *Service Component* for a given technology before an appropriate set of parameters and notifiable events can be defined.

2.3 FUNCTIONAL RESOURCE SETS

The Functional Resource Stratified model is similar to the ISO Open System Interconnection (OSI) seven-layered reference model (reference needed): by itself it is abstract and incapable of being implemented, but it provides a framework into which implementable specializations of those ASCs can be inserted. When every ASC has a corresponding SC, the resulting configuration is implementable (subject to compatibility constraints – if any – among the specific specializations).

DRAFT TECHNICAL NOTE CONCERNING THE FUNCTIONAL RESOURCE REFERENCE
MODEL

A set of FR Types is defined for each SC. The SC also defines the relationships among the component FR Types, and which of those FR Types implement the extension point interfaces of the ASC.

Figure 2-4 depicts the SCs that support the service configurations in IOAG Service Catalogs #1 (reference [9]) and #2 (reference [16]). Each of these specializations corresponds to a CCSDS Recommended Standard. Within the rounded box for each ASC, the SCs of that ASC are depicted as dashed-border rounded boxes. In two cases (SLS Radiometric Data Production and Offline Data Storage) the ASC boxes are not large enough for the SCs. In these cases the SCs are shown in separate boxes at the bottom of the diagram.

NOTES

- 1 In Figure 2-4 and subsequent figures that depict the SCs that specialize the ASCs, the placement of the SC icons within the ASC icons is not related to the position of the arrows entering and leaving the containing parent icons. The figures merely indicate that the SCs belong to their parent ASCs. However, for those ASCs that have both forward and return SCs, the forward SCs are shown in the upper part of the ASC icons, and the return SCs are shown in the lower part of the ASC icons.
- 2 The functionalities of the CCSDS 401 SC specializations of the Forward Physical Channel Transmission and Return Physical Channel Reception ASCs conform to the CCSDS 401 Recommended Standards for radio frequency and modulation (reference [23]) and optionally to the CCSDS Recommended Standard for pseudo-noise (PN) ranging (reference [24]) where Code Division Multiple Access (CDMA) is not employed. These are the two physical channel-layer Recommended Standards that are explicitly called out in IOAG Service Catalogs #1 (reference [9]) and #2 (reference [16]). IOAG services could also be performed over links that use CDMA in accordance with reference [25], for which different SC specializations of Forward Physical Channel Transmission and Return Physical Channel Reception ASCs will exist.

The functionality of a Service Component is provided by the Functional Resource(s) that comprise that Service Component. The functional resource types that comprise each of the Service Components are identified in subsequent chapters of this Tech Note.

When a Service Component contains two or more functional resource types, the relationships among the functional resources in the same Service Component are expressed as *containment* relationships. These containment relationships represent the flow of data or information among the functional resources within the Service Component. By convention, the containment relationships flow *away from the space link*, regardless of the direction of the data flow between among those functional resources. This convention is driven by the multiplexing and demultiplexing nature of space link communications, where multiple user data flows are multiplexed across the space link. For example, a master channel multiplexer FR instance contains multiple virtual channel multiplexer FR instances, and a master channel demultiplexer FR instance contains multiple virtual channel demultiplexer FR instances.

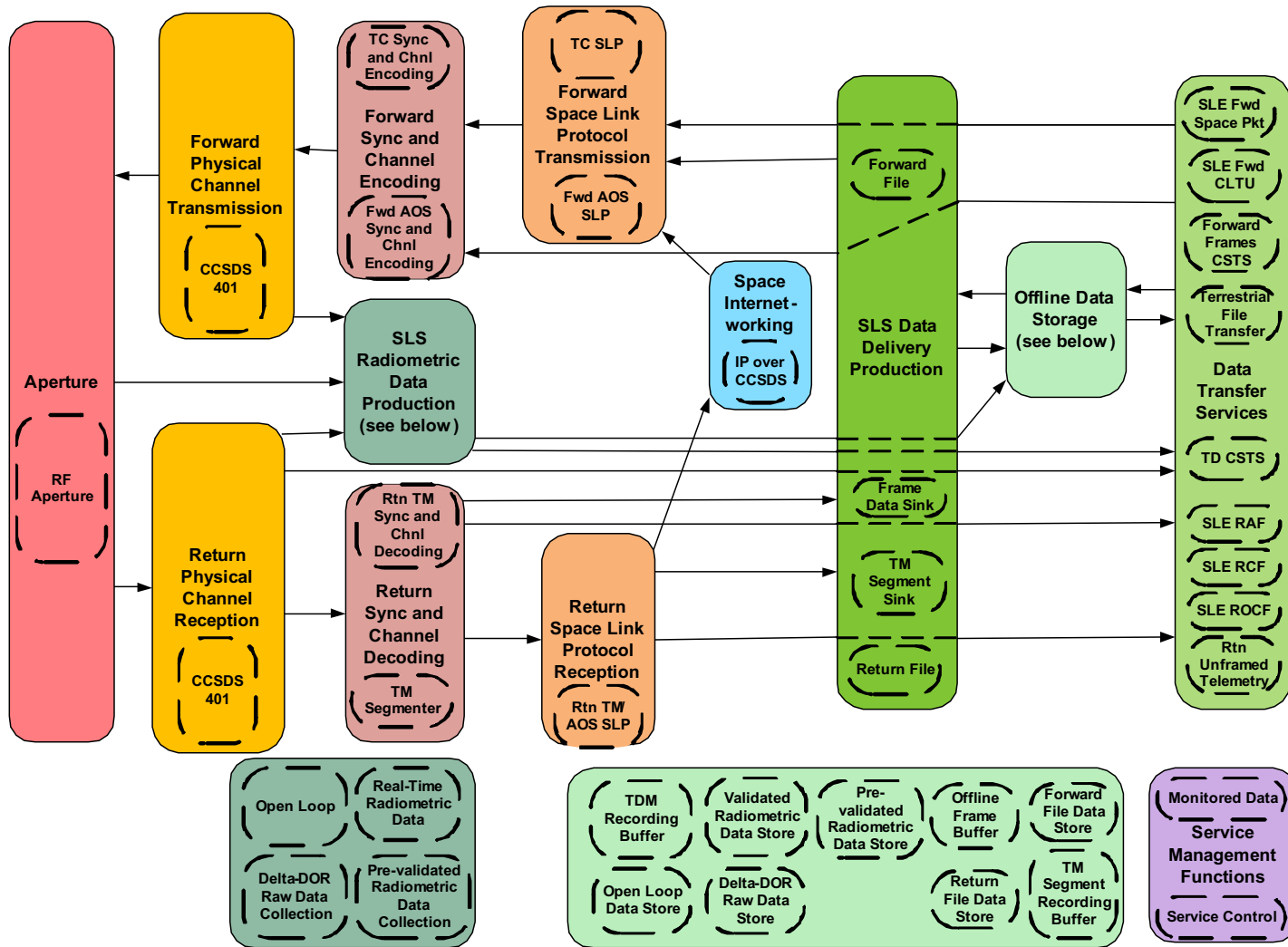

Figure 2-4: Functional Resources Sets within the Strata

2.4 PORT PAIRS

Whereas relationships among functional resources within the same Service Component are represented by containment, relationships among difference Service Components are represented by associations that are defined by *port pairs*. Port pairs are asymmetrical, with one port serving as the *Service Access Point* (SAP) port and the other the *Accessor* port.

The purpose of the port-pair associations is to define the relationships among SC instances *so that those SC instances can be properly configured*. That is, the port-pair associations are artifacts of Service Management. In the majority of cases the port pair associations represent the associations between SC instances that form the “layers” of a space communication protocol stack. For example, an instance of an SC specialization of the Forward Sync and Channel Encoding ASC and an instance of an SC specialization of the Forward Physical Channel Transmission ASC are connected via a port pair association in a configuration profile, which tells Service Management that these two SC instances are connected in order to flow Forward Physical Channel Symbols between those two SCs. In the case of such “intra-stack” port pairs, the convention is to designate the port of the ASC/SC that is “nearer” to the space link as the SAP port. In the case of the example given in this paragraph, the SC specialization of the Forward Physical Channel Transmission ASC has the SAP port, and the SC specialization of the Forward Sync and Channel Encoding ASC and an SC specialization of the Forward Physical Channel Transmission ASC.

Port pair associations are also used to represent relationships among SCs in different space communication stacks. For example, a coherence relationship between a forward and return space link carrier is represented by a port pair. Another example of such “inter-stack” associations is the port pair that relates the an instance of the Return Sync and Channel Decoding SC that processes a specific return link CLCW carrying Master Channel or Virtual Channel to the instance of the TC Sync and Channel Encoding SC that uses those CLSWs to regulate its PLOP. When the association represents such an inter--stack relationship, the designation of SAP port and Accessor port roles depends on the relative dependence of the two SCs in that relationship, where the “independent” SC is assigned the SAP port and the dependent SC is assigned the Accessor port. In the space link coherence example, where the frequency of the return link depends on the frequency of the forward link, the forward link carrier assumes the SAP port role and the return link carrier assumes the Accessor port role.

Note that in addition to inter-stack relationship information being specified explicitly via a port pair association, inter-stack relationship information may be specified implicitly via other port-pair associations. That is, if SC instance B has a port-pair association with SC instance C for the purpose of establishing a configuration relationship between B and C, SC instance A can inherit that relationship information about SC instance C from SC instance B if A is also associated with B, as long as the relationship between A and C involves the same configuration information as the relationship between B and C.

Port pairs can be associated with ASCs and SCs. The port pairs that are associated with ASCs are referred to as *essential* port pairs, because they are related to the essence of the ASC and not just to a particular specialization of that ASC. For example, for the Aperture

ASC, Return Modulated Waveform and Forward Modulated Waveform SAP ports are essential ports because radiating modulated waveforms is intrinsic to the aperture.

Essential port pairs are available for use by the SCs that specialize the ASCs for which the essential ports pairs are defined. However, “essential” is not to the same as “mandatory.” In general, SCs must implement the Accessor ports of their parent ASCs, but there is more flexibility in use of SAP ports. A satellite television antenna is a specialization of the Aperture ASC, but it does not use the Forward Modulated Waveform SAP port.

SCs can add their own specialized port pairs, to represent inter-SC data flows or other relationships that are specific to the SC. The ports (both essential and specialized) are assigned to the Functional Resources that comprise each SC. The assignment of a port to a FR within an SC is represented as a containment relationship, with the FR object containing the port object.

NOTE - Although port objects are contained by FR objects within SCs, the port object is not a essential to the definition of the FR itself. FRs are available for reuse by other SCs, where other port relationships may apply.

Each SAP port contains a *port instance number* that must be unique in any configuration. Each Accessor port that associates with that SAP port also contains – in addition to its own unique its own port instance number - the name of the functional resource that contains the peer SAP port and the port instance number of that peer SAP port.

Even though the essential ports are associated with specific ASCs and specialized ports are initially created because of the needs of specific SCs, those port types are not exclusive to those ASCs and SCs. They available for use by other ASCs and SCs.

2.5 SERVICE CONFIGURATION CATEGORIES

For Service Management purposes (e.g., scheduling), the SCs (and the FRs that comprise them) are used in three categories of configurations:

- a. The Space Link Session (SLS) configuration category, which comprises the functions of the ESLT that:
 1. transfer data to or from one or more Space User Nodes of a CSSS across one or more space links during an SLS;
 2. provide forward and/or return data transfer services during an executing SLS so that one or more Earth User Nodes communicate with the Space User Node(s) with end-to-end connectivity in “real time”; and
 3. extract radiometric measurements from space links of an active SLS and deliver those measurements to the destination Earth User Node in “real time”.
- b. The retrieval configuration category, which comprises the functions or the ESLT that:
 1. deliver data that was received from a Space User Node to an Earth User Node, but not necessarily during the execution of the SLS by which the data was received; and

2. deliver radiometric measurements to the Earth User Node, but not necessarily during the execution of the SLS during which the radiometric measurements were extracted;
- c. The forward offline data delivery configuration, in which the ESLT receives and stores data from an Earth User Node destined for a Space User Node, before the execution of the SLS by which the data is transmitted to the Space User Node.

These configuration categories are reflected in both Service Agreements and Configuration Profiles, as described in later sections of this Tech Note.

2.5.1 SLS CONFIGURATION CATEGORY

Figure 2-5 illustrates the ASCs that are used in the SLS configurations, including the Space Internetworking ASC for Service Catalog #2 services. Figure 2-6 shows the connectivity among the SC specializations of those ASCs.

The SLS configuration category involve all of the ASCs for ESLTs, but only part of the functionality of the following ASCs is used for the provision of services during an SLS:

- a. The Data Transfer Services ASC is limited to those services that allow Earth User Nodes to interface with the ESLT for the purpose of (1) exchanging data with their respective Space User Nodes in real time via the space links provided by the ESLT, and (2) receiving radio metric data in real time. These SLS cross support transfer services include *online* SLE Transfer Services (see reference [1]) and *realtime* CSTSes (see reference [4]).
- b. The Offline Data Storage ASC is constrained to those functions associated with (1) transferring to Space User Nodes data that had been received by the ESLT prior to the SLS, (2) receiving and storing data from Space User Nodes for subsequent transfer to Earth User Nodes, and (3) storing radiometric data for subsequent transfer to Earth User Nodes.

Figure 2-7 shows the individual Functional Resource types that are used in SLS configurations. The allocation of specific FR types to specific SC specializations is documented in section 4.

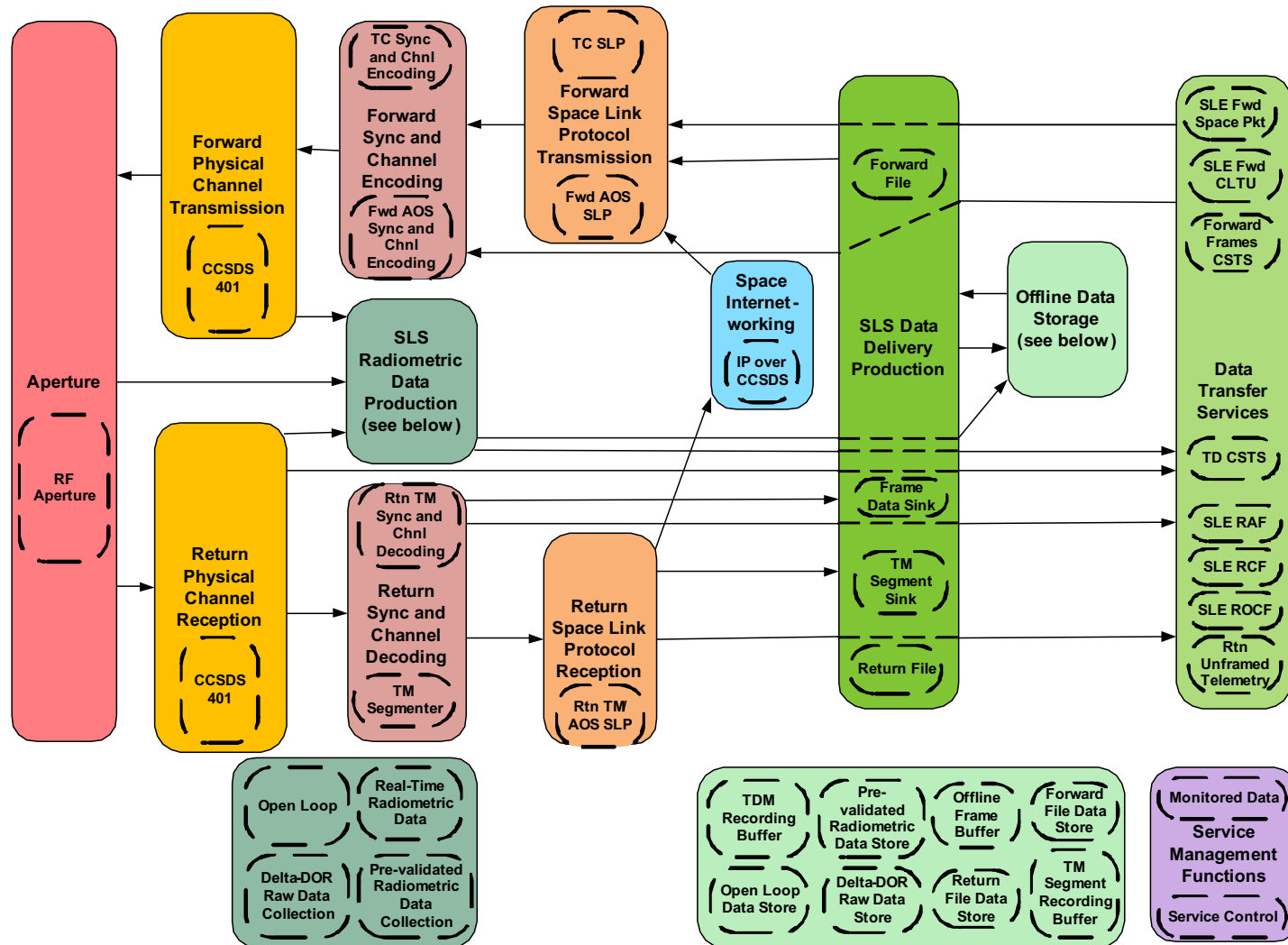

Figure 2-5: Functional Resource Strata Used in SLS Configurations

DRAFT TECHNICAL NOTE CONCERNING THE FUNCTIONAL RESOURCE REFERENCE MODEL

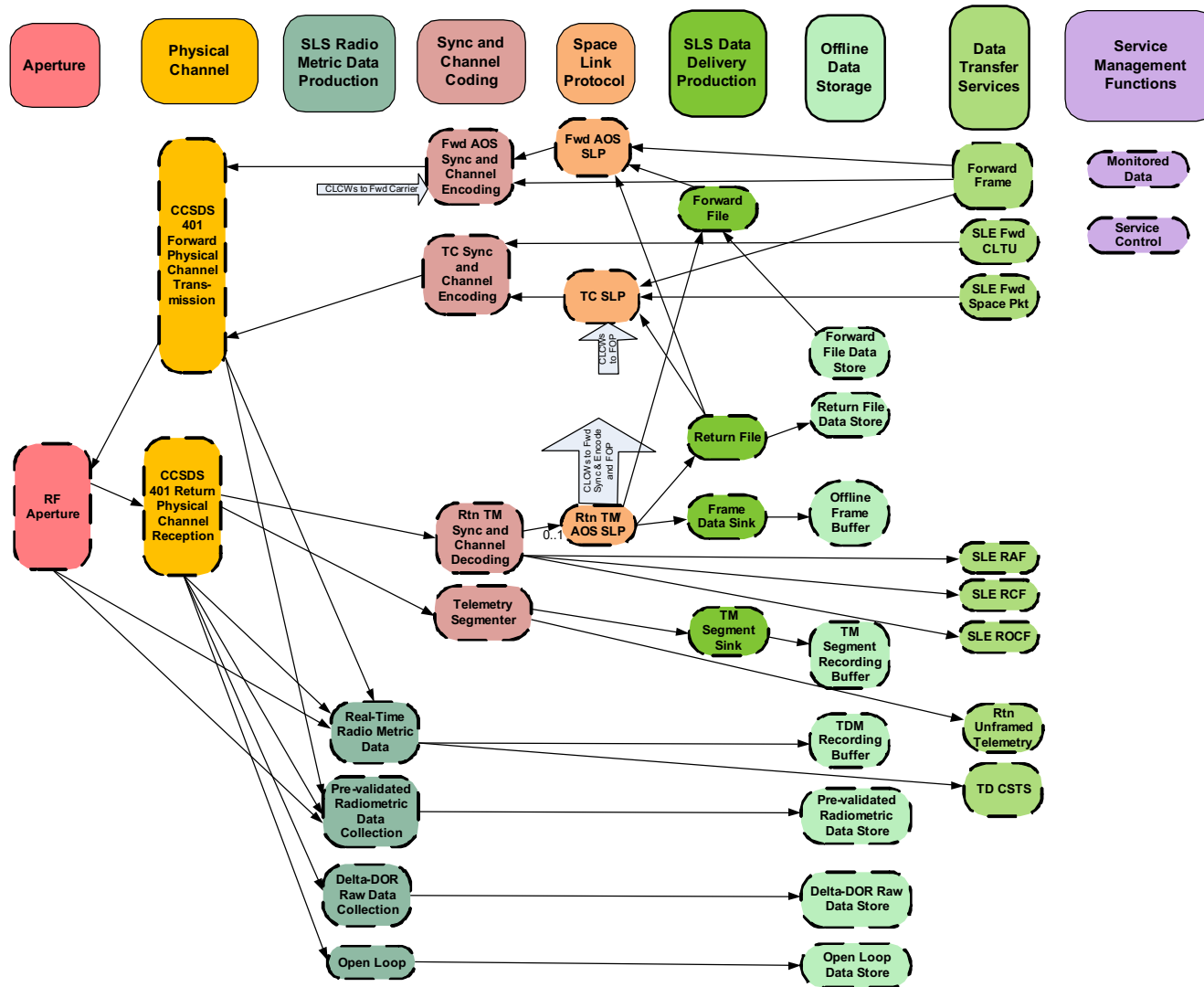

Figure 2-6: Connectivity of Functional Resource Sets in SLS Configurations

DRAFT TECHNICAL NOTE CONCERNING THE FUNCTIONAL RESOURCE REFERENCE MODEL

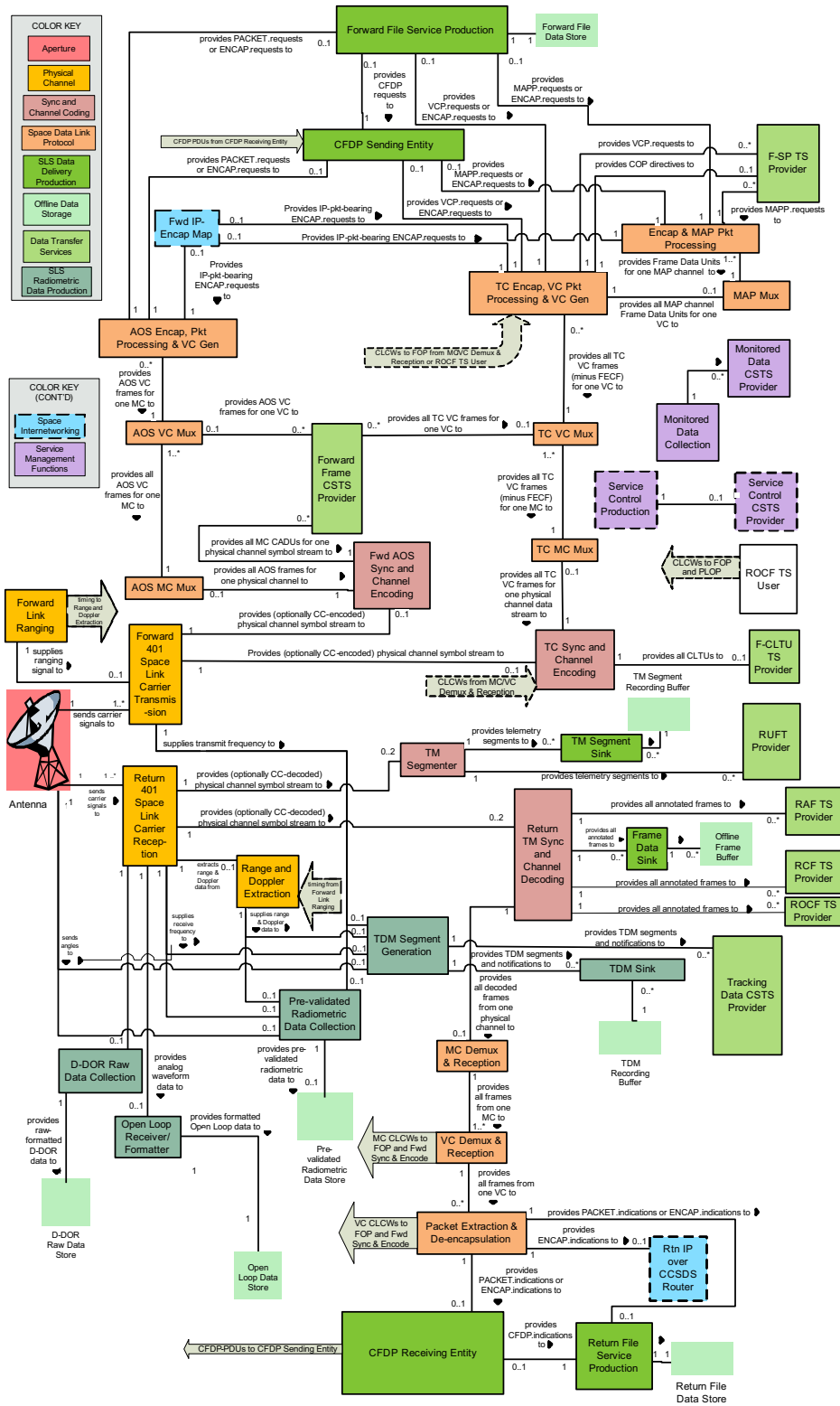

Figure 2-7: Functional Resource Types Used in SLS Configurations

2.5.2 RETRIEVAL CONFIGURATION CATEGORY

The retrieval configuration category does not require the above space link communications stack, although in some cases the space link stack may be present. The minimal retrieval configuration is composed of an Offline Data Storage SC and a Data Transfer Services SC. The data transfer services that are included in the retrieval configuration category include *offline* SLE Transfer Services (see reference [1]), *complete* CSTSes (see reference [4]), the Terrestrial File Transfer service, and the offline retrieval of space data files captured by the ESLT.

Figure 2-8 shows the ASCs used in the retrieval data delivery and retrieval metric data configurations. Figure 2-9 shows the connectivity among the specializations of those ASCs. Figure 2-10 shows the individual Functional Resource types that are used in retrieval configurations. The allocation of specific FR types to specific SC specializations is documented in section 4.

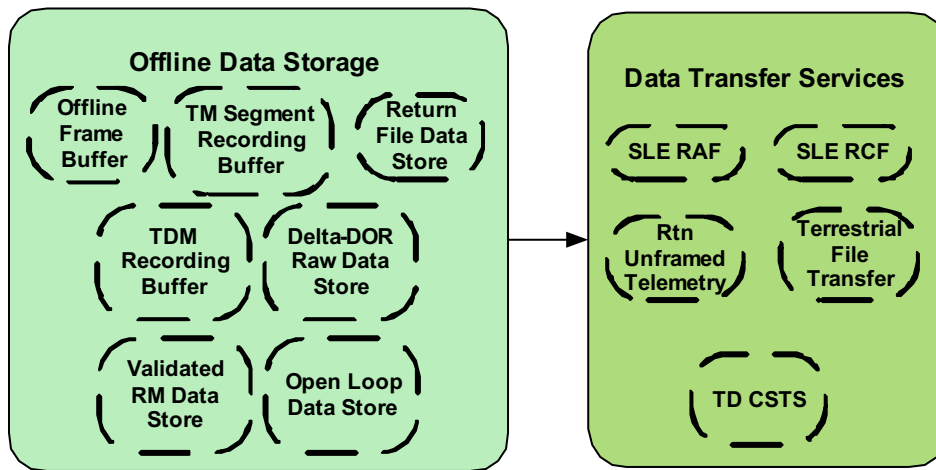

Figure 2-8: Functional Resource Strata Used in Retrieval Configurations

DRAFT TECHNICAL NOTE CONCERNING THE FUNCTIONAL RESOURCE REFERENCE MODEL

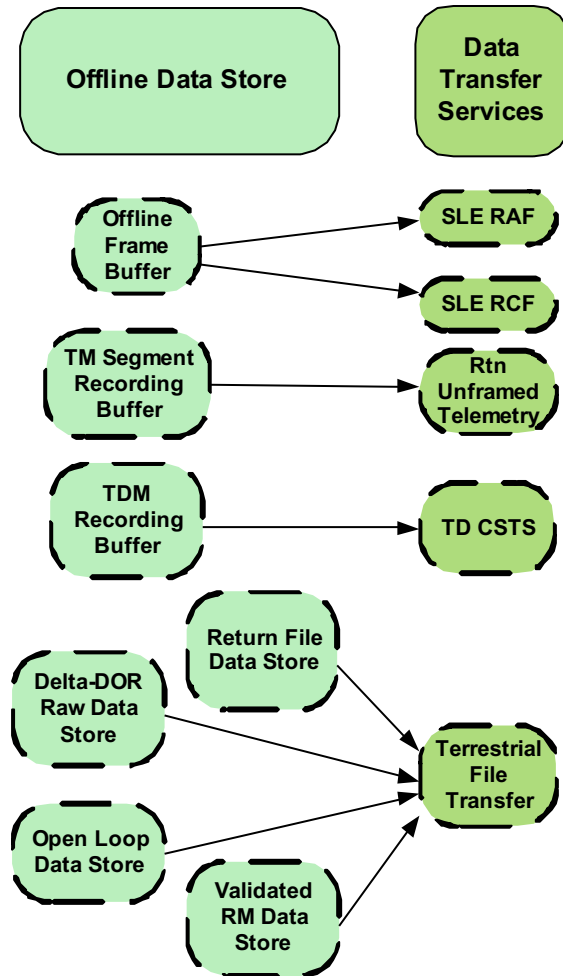

Figure 2-9: Connectivity of Functional Resource Sets in in Retrieval Configurations

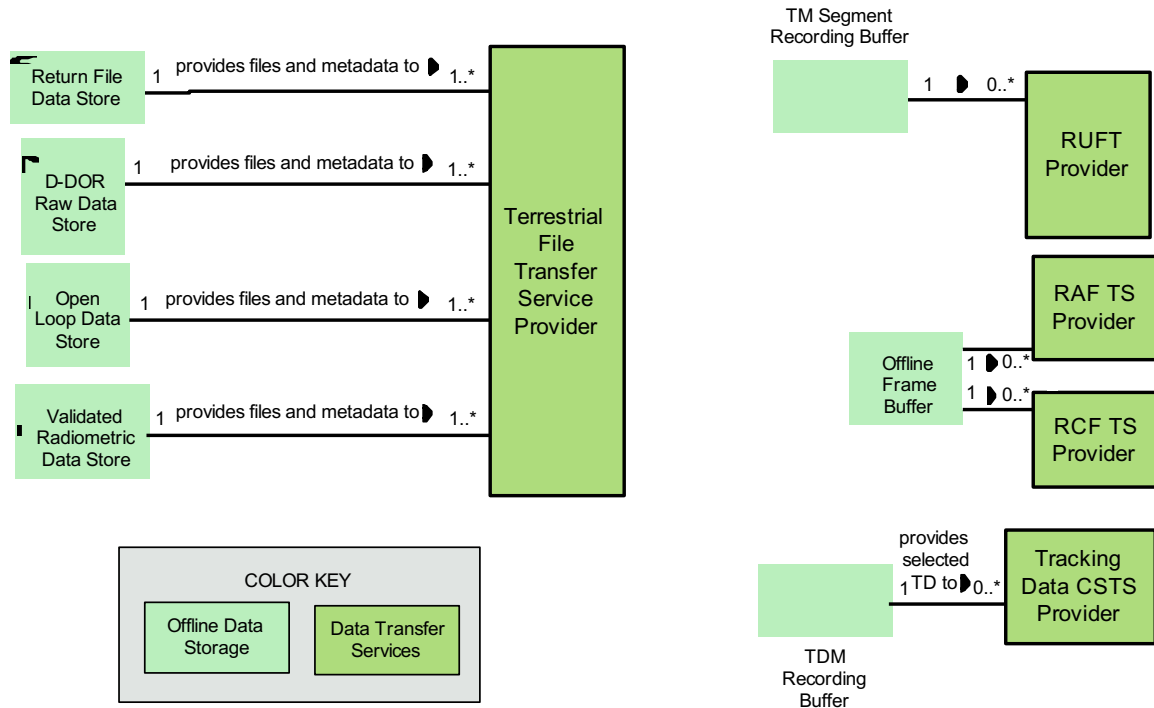

Figure 2-10: **Functional Resource Types Used in Retrieval Configurations**

2.5.3 FORWARD OFFLINE DATA DELIVERY CONFIGURATION

The forward offline data delivery configuration does not involve the space link communications stack – it is composed of a forward offline cross support transfer service and a forward space link data store.

There is only one IOAG Service Catalog 1 service that operates using the forward offline data delivery configuration, the Forward File service. Figure 2-11 shows the ASCs used in the forward offline data delivery configuration.

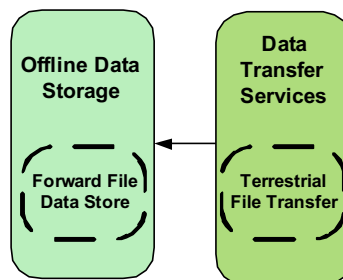

Figure 2-11: **Functional Resource Strata Used in Forward Offline Data Delivery Configurations**

Figure 2-12 shows the individual Functional Resource types that are used in the forward offline data delivery configuration. The allocation of specific FR types to specific SC specializations is documented in section 4.

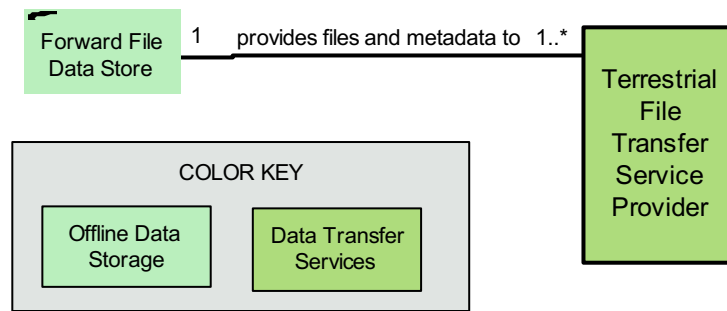

Figure 2-12: **Functional Resource Types Used in Forward Offline Data Delivery Configurations**

2.6 SERVICE PROFILES

A *Service Profile* identifies the SCs and FRs that are needed to provide a single instance of a cross support service such as SLE Return All Frames or Forward Frames CSTS.

A Service Profile identifies all of the SCs and FRs that could be used to provide an instance of the service. In many cases, a cross support service may use any of several SCs for a given ASC (although there may be constraints on the feasible combinations of specific SCs). The Service Profile identifies these different possible combinations of SCs. The Service Profile also identifies those ASCs (if any) for which future specializations could possibly substitute for those listed in the current Service Profile.

In some cases, a Service Profile for a given service may use part of a Service Component but not all of it. Any parts of a Service Component (either whole FRs or just a subset of the functionality of one or more FRs) that are never used in the provision of that service are so identified in its Service Profile.

The Service Profile is not itself implementable – it is a tool for identifying the SCs that must be present in Service Agreements and Configuration Profile Information Entities to provide the desired services. The Service Profiles for the IOAG Service Catalog #1 services are specified in sections 5, 6, and 7.

As an example of Service Component-level composition of a Service Profile, Figure 2-13 (a copy of figure 5-1) illustrates the composition of the Service Profile of the Forward CLTU service in the SLS Configuration. For each such service in in sections 5, 6, and 7, a comparable Service Profile diagram is provided.

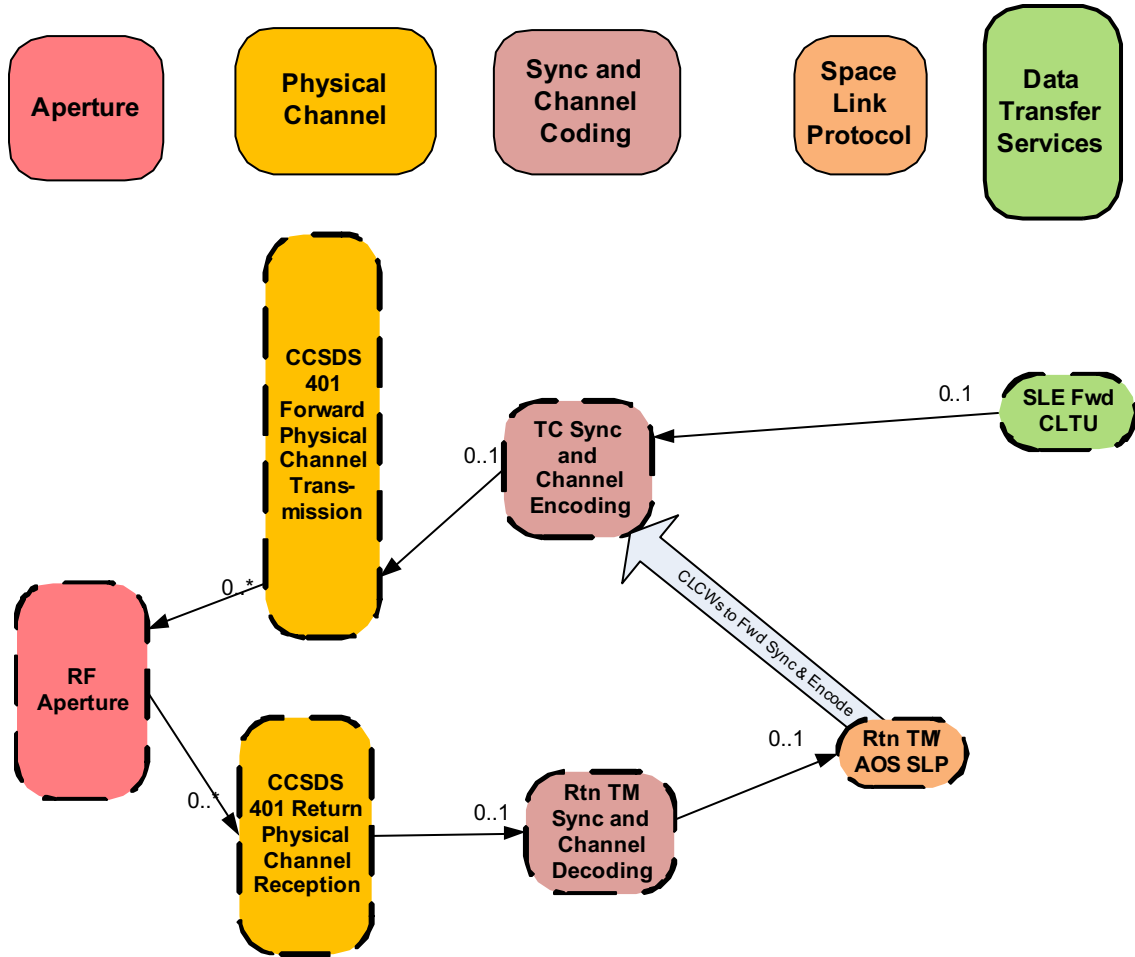

Figure 2-13: Functional Resource Sets Used in Forward CLTU SLS Configuration

Figure 2-14 goes within the Service Components in the Forward CLTU to show the functional resources within those Service Components, and how they are connected and used within the Forward CLTU SLS Configuration Service Profile. This diagram is provided here to illustrate the internal structure of Service Profiles, but similar diagrams are not provided for the Service Profiles in sections 5, 6, and 7. However, section 4 provides the internal Functional Resource structure for each Service Component, so the equivalent information can be obtained by combining the information in sections 4, 5, 6, and 7 as appropriate.

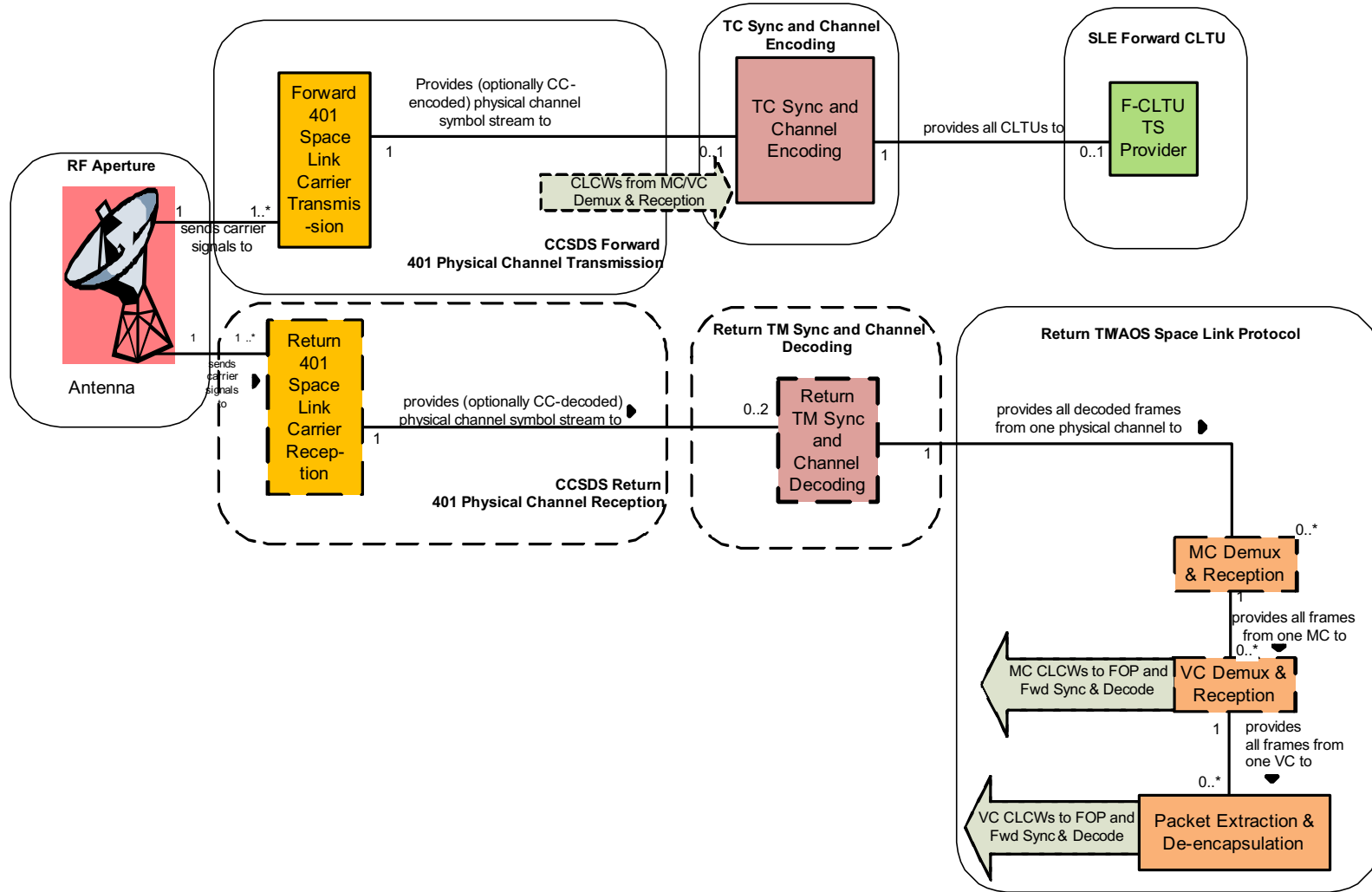

Figure 2-14: Functional Resource Types of the Forward CLTU Forward Data Delivery Service

2.7 SERVICE COMPONENT-BASED INFORMATION ENTITIES

Author's Note – This is just a collection of notes at this point. These will need to be fleshed out.

NOTE - Some of these Info Entities (e.g., Service Agreement and Configuration Profile) are themselves aggregations of other Info Entities. Some might argue that only the highest level “entities” should be Info Entities, but anything that can be separately addressed (and possibly altered and/or deleted) qualifies as an Info Entity.

2.7.1 SERVICE COMPONENT AGREEMENT

A Service Component Agreement defines the set of allowed values/ranges for parameters of a Service Component. A Service Agreement *may* have multiple Service Component Agreements for the same Service Component type (more on this in a moment), e.g., corresponding to X-band and S-band settings for the FRs in the CCSDS 401 Return Physical Channel Reception SC.

2.7.2 SERVICE COMPONENT PROFILE

A Service Component Profile defines the single specific value for each of the configurable parameters of the enabled functional resources of a Service Component. No port linkage information is specified.

2.7.3 SPACE COMMUNICATION SERVICE PROFILE

A Space Communication Service Profile is a collection of Service Component Profiles (by reference). The port linkage information *is* specified. F&Cs can also be specified among FRs in the SCSP (limited to space link carrier FRs?).

[It occurs to me that if a mission, for example, uses its X and S-band links in a coordinate fashion, it should be possible to create an SCSP with all SCs included: Forward S, Return S, Forward X, and Return X. The F&Cs for the SCSP could then link across the two chains. Would this complicate the composition rules?]

An SCSP *may* contain Data Transfer Service Components, but if it does those Data Transfer Service Components are dedicated to those SCSPs. Alternatively, An SCSP may contain Transfer Service Maps (what do these look like) that associate with transfer services that are configured and controlled via separately-instantiated Transfer Service Profiles. In this latter case, the Transfer Service instances persist independent of the SCSPs that associate with them. [We didn't get to talk about this on the telecon today, but it's something that I've been thinking about and am recording it here for future discussion.]

2.7.4 SERVICE AGREEMENT

A Service Agreement Info Entity consists of:

DRAFT TECHNICAL NOTE CONCERNING THE FUNCTIONAL RESOURCE REFERENCE
MODEL

- a. Zero or more Service Component Agreements, each with a unique identifier. Service Component Agreements are present **only** in cases where Service Component Profiles can subsequently be created in Configuration Profile Info Entities.
- b. Zero or more Service Component Profiles. These are present if (1) the Service Agreement itself contains operational configuration profiles (SCSPs and/or Transfer Service Profiles) and/or (2) there is the desire/capability to subsequently create Configuration Profile Info Entities and to use a “starter set” of SC Profiles; **and/or**
- c. Zero or more SCSPs. If any of these are present, they must be composed of the SC Profiles specified within the Service Agreement ((b), above). If any of these SCSPs contain TsMaps, then the Data Transfer Service Component Profiles to which they map must also be specified within the Service Agreement (see (b), above).

We discussed whether the Service Agreement should also have Space Communication Service Agreements to constrain the possible configurations of SC Agreements, and decided not to do so for simplicity. If reviewers see a need to specify such constraints, we will reconsider down the road.

2.7.5 CONFIGURATION PROFILE

A Configuration Profile Info Entity consists of:

- a. Zero or more Service Component Profiles. Each contained Service Component Profile must cross-reference the applicable SC Agreement; **and/or**
- b. Zero or more SCSPs. The SC Profiles must reference SC Profiles that (1) have been specified as part of the applicable Service Agreement, (2) have been specified in another Configuration Profile Info Entity, or (3) are specified in the same Config Profile Info Entity. If any of these SCSPs contain TsMaps, then the Data Transfer Service Component Profiles to which they map must also be specified within the Service Agreement, another Config Profile IE, or the same Config Profile IE.

[The TsMap is conceptually similar to a port, but it may have to have more persistent/global identification so that it can be reused by different SCSPs.]

3 FUNCTIONAL RESOURCE SETS, SERVICE ASSOCIATION ROLES, AND PROVIDED/REQUIRED INTERFACES

This section provides a “black box” view of the Functional Resource strata and the current set of Functional Resource sets for each Functional Resource stratum. If the FR stratum is defined as an Accessor of a specific service association, that role is identified. If the FR stratum provides SAPS for one or more essential service associations, those SAPS are identified. For each FR set, the SAP and Accessor roles of that FR set are named. If the FR set has Porvided or Required interface, those interfaces are also identified.

As new specializations of the ASCs are created, they will be added to this section.

3.1 FUNCTIONAL RESOURCE SETS OF THE APERTURE STRATUM

The Aperture FR stratum has no Accessor role because it terminates the configuration on the space link side. The Aperture FR stratum has the following essential SAPs:

- Forward Modulated Waveform;
- Return Modulated Waveform.

Table 3-1 identifies the current specializations of the Aperture ASC.

Table 3-1: Aperture Functional Resource Sets and Their Associated Accessor Role, SAPs and Required/Provided Interfaces

Functional Resource Set	Accessor Role	SAPs	Provided Interface	Required Interface
RF Aperture	n/a	Forward Modulated Waveform Return Modulated Waveform	Pointing Angles	n/a

3.2 SPECIALIZATIONS OF THE FORWARD PHYSICAL CHANNEL TRANSMISSION ASC

The Forward Physical Channel Transmission ASC has the following essential Accessor ports:

- Forward Modulated Waveform

The Forward Physical Channel Transmission ASC has the following essential SAP ports:

- Forward Channel Symbols
- Transmit Frequency

- Ranging Signal Timing

Table 3-2 identifies the current specializations of the Forward Physical Channel Transmission ASC.

Table 3-2: Forward Physical Channel Transmission ASC Service Component Specializations and Their Associated SAP and Accessor Ports

Specialization	Accessor Port	SAP Port(s)
CCSDS 401 Forward Physical Channel Transmission.	Forward Modulated Waveform (essential)	Forward Physical Channel Symbols (essential) Transmit Frequency (essential) Ranging Signal Timing (essential)

3.3 SPECIALIZATIONS OF THE FORWARD SYNC AND CHANNEL ENCODING ASC

The Forward Sync and Channel Encoding ASC has the following essential Accessor ports:

- Forward Physical Channel Symbols

The Forward Sync and Channel Encoding ASC has the following essential SAP ports:

- Forward All Transfer Frames

Table 3-3 identifies the current specializations of the Forward Sync and Channel Encoding ASC.

Table 3-3: Forward Sync and Channel Encoding ASC Service Component Specializations and Their Associated SAP and Accessor Ports

Specialization	Accessor Port	SAP Port(s)
TC Sync and Channel Encoding	Forward Physical Channel Symbols (essential) CLCW (specialization)	Forward All Transfer Frames (essential) CLTU (specialization)
AOS Sync and Channel Encoding	Forward Physical Channel Symbols (essential)	Forward All Transfer Frames (essential) Forward AOS CADU (specialization)

3.4 SPECIALIZATIONS OF THE FORWARD SPACE LINK PROTOCOL TRANSMISSION ASC

The Forward Space Link Protocol Transmission ASC has the following essential Accessor ports:

- Forward All Transfer Frames

The Forward Space Link Protocol Transmission ASC has the following essential SAP ports:

- Forward Packet

Table 3-4 identifies the current specializations of the Forward Space Link Protocol Transmission ASC.

Table 3-4: Forward Space Link Protocol Transmission ASC Service Component Specializations and Their Associated SAP and Accessor Ports

Specialization	Accessor Port	SAP Port(s)
TC Space Link Protocol Transmission	Forward All Transfer Frames (essential) CLCW (specialization)	Forward Packet (essential) TC VC Frames (specialization)
Forward AOS Space Link Protocol Transmission	Forward All Transfer Frames (essential)	Forward Packet (essential) Forward AOS VC Frames (specialization)

3.5 SPECIALIZATIONS OF THE RETURN PHYSICAL CHANNEL RECEPTION ASC

The Return Physical Channel Reception ASC has the following essential Accessor ports:

- Return Modulated Waveform
- Transmit Frequency

The Return Physical Channel Reception ASC has the following essential SAP ports:

- Return Physical Channel Symbols
- Receive Frequency
- Range and Doppler
- Analog Waveform

Table 3-5 identifies the current specializations of the Return Physical Channel Reception ASC.

Table 3-5: Return Physical Channel Reception ASC Service Component Specializations and Their Associated SAP and Accessor Ports

Specialization	Accessor Port	SAP Port(s)
CCSDS 401 Return Physical Channel Reception	Return Modulated Waveform (essential) Transmit Frequency (essential) Ranging Signal Timing (essential)	Return Physical Channel Symbols (essential) Range and Doppler (essential) Receive Frequency (essential) Analog Waveform (essential) DOR Tones (specialization)

3.6 SPECIALIZATIONS OF THE RETURN SYNC AND CHANNEL DECODING ASC

The Return Sync and Channel Decoding ASC has the following essential Accessor ports:

- Return Physical Channel Symbols

The Return Sync and Channel Decoding ASC has the following essential SAP ports:

- Return All Transfer Frames

Table 3-6 identifies the current specializations of the Return Sync and Channel Decoding ASC.

Table 3-6: Return Sync and Channel Decoding ASC Service Component Specializations and Their Associated SAP and Accessor Ports

Specialization	Accessor Port	SAP Port(s)
Return TM Synchronization and Channel Decoding	Return Physical Channel Symbols (essential)	Return All Transfer Frames (essential) Return All Annotated Transfer Frames (specialization)
Telemetry Segmenter	Return Physical Channel Symbols (essential)	Return All Transfer Frames (essential)

3.7 SPECIALIZATIONS OF THE RETURN SPACE LINK PROTOCOL RECEPTION ASC

The Return Space Link Protocol Reception ASC has the following essential Accessor ports:

- Return All Transfer Frames

The Return Space Link Protocol Reception ASC has the following essential SAP ports:

- Return Packet

Table 3-7 identifies the current specializations of the Return Space Link Protocol Reception ASC.

Table 3-7: Return Space Link Protocol Reception ASC Service Component Specializations and Their Associated SAP and Accessor Ports

Specialization	Accessor Port	SAP Port(s)
Return TM/AOS Space Link Protocol Reception	Return All Transfer Frames (essential)	Return Packet (essential) CLCW (specialization)

3.8 SPECIALIZATIONS OF THE SLS DATA DELIVERY PRODUCTION ASC

The SLS Data Delivery Production ASC has no essential Accessor ports. All Accessor ports are specific to the SC specializations Return Packet.

The SLS Data Delivery Production ASC has no essential SAP ports. All SAP ports are specific to the SC specializations.

Table 3-8 identifies the current specializations of the SLS Data Delivery Production ASC.

Table 3-8: SLS Data Delivery Production ASC Service Component Specializations and Their Associated SAP and Accessor Ports

Specialization	Accessor Port	SAP Port(s)
Forward File Data Delivery Production	Forward Packet (essential) Ack CFDP-PDU (specialization)	Forward Space Data File (specialization)
Frame Data Sink	Return All Annotated Transfer Frames (specialization)	Return Selected Transfer Frames (specialization)
TM Segment Sink	Return All Transfer Frames (specialization)	Return All TM Segments (specialization)
Return File Data Delivery Production	Return Packet (essential)	Return Space Data File (specialization) Ack CFDP-PDU (specialization)

3.9 SPECIALIZATIONS OF THE SLS RADIOMETRIC DATA PRODUCTION ASC

The Return Space Link Protocol Reception ASC has the following essential Accessor ports:

- Transmit Frequency
- Receive Frequency
- Range and Doppler

The SLS Radiometric Data Production ASC has no essential SAP ports. All SAP ports are specific to the SC specializations.

Table 3-9 identifies the current specializations of the SLS Radiometric Data Production ASC.

**Table 3-9: SLS Radiometric Data Production ASC Service Component Specializations
and Their Associated SAP and Accessor Ports**

Specialization	Accessor Port	SAP Port(s)
Pre-Validated Radiometric Data Collection	Range and Doppler (essential) Receive Frequency (essential) Transmit Frequency (essential) Pointing Angles (specialization)	Pre-Validated Radiometric Data (specialization)
Real-Time Radiometric Data Collection	Range and Doppler (essential) Receive Frequency (essential) Transmit Frequency (essential) Pointing Angles (specialization)	TDM Segments (specialization)
Delta-DOR Raw Data Collection	DOR Tones (specialization).	Raw-formatted D-DOR Data (specialization)
Open Loop Receiver/Formatter	Analog Waveform (specialization).	Formatted Open Loop Data (specialization)

3.10 SPECIALIZATIONS OF THE OFFLINE DATA STORAGE PRODUCTION ASC

The Offline Data Storage ASC has no essential Accessor ports. All Accessor ports are specific to the SC specializations.

Table 3-10 identifies the current specializations of the Offline Data Storage ASC.

**Table 3-10: Offline Data Storage ASC Service Component Specializations and Their
Associated SAP and Accessor Ports**

Specialization	Accessor Port	SAP Port(s)
Forward File Data Store	Forward Space Data File (specialization)	Forward File (specialization)
Offline Frame Buffer	Return Selected Transfer Frames (specialization)	Return All Buffered Transfer Frames (specialization)
TM Segment Recording Buffer	Return All TM Segments (specialization)	Return Buffered TM Segments (specialization)
Return File Data Store	Return Space Data File (specialization)	Return File (specialization)
Pre-Validated Radiometric Data Store	Pre-Validated Radiometric Data (specialization)	n/a
Validated Radiometric Data Store	n/a	Return File (specialization)
TDM Segment Recording Buffer	TDM Segments (specialization)	Buffered TDM Segments (specialization)
Delta-DOR Raw Data Store	Raw-formatted D-DOR Data (specialization)	Return File (specialization)
Open Loop Data Store	Formatted Open Loop Data	Return File (specialization)

3.11 SPECIALIZATIONS OF THE DATA TRANSFER SERVICES ASC

The Data Transfer Services ASC has no essential Accessor ports. All Accessor ports are specific to the SC specializations.

The Data Transfer Services ASC has no SAP Ports because it terminates the configuration on the ground side.

Table 3-11 identifies the current specializations of the Data Transfer Services ASC.

**Table 3-11: Data Transfer Services ASC Service Component Specializations and Their
Associated Accessor Ports**

Specialization	Accessor Port
Forward CLTU	CLTU (specialization)
Forward Space Packet	Forward Packet (specialization)
Forward Frame	TC VC Frames (specialization). Forward AOS VC Frames (specialization). Forward AOS CADU (specialization)
SLE Return All Frames	Return All Annotated Transfer Frames (specialization). Return All Buffered Transfer Frames (specialization)
SLE Return Channel Frames	Return All Annotated Transfer Frames (specialization) Return All Buffered Transfer Frames (specialization)
SLE ROCF	Return All Annotated Transfer Frames (specialization)
Return Unframed Telemetry (RUFT)	Return All Transfer Frames (specialization) Return Buffered Unframed Telemetry Segments (specialization)
Tracking Data CSTS	TDM Segments (specialization) Buffered TDM Segments (specialization)
Terrestrial File Transfer Service	Forward File (specialization) Return File (specialization)

4 FUNCTIONAL RESOURCE TYPES FOR FUNCTIONAL RESOURCE SETS

This section describes the Functional Resource Types that represent the functions that are performed by ESLTs. Primarily, these Functional Resource Types are the ones that represent the functions that are performed in providing IOAG Service Catalog 1 services. However, several other FR Types – corresponding to IOAG Service Catalog 2 services and another future service – are also described to illustrate how future capabilities can be accommodated.

In this section, the Functional Resource Types are organized by the Functional Resource Sets to which they belong. These FR sets are in turn organized by the FR strata that they specialize. For each Functional Resource Type, the corresponding Functional Resource Type Object Classifier is listed and the pertinent CCSDS Recommended Standard is identified. The Object Classifiers map to the Object Identifiers that are assigned to the Functional Resources in the SANA Functional Resource Registry, and the Object Classifiers serve as a key into that registry.

The Functional Resource Type OIDs are registered under the `crossSupportFunctionalities` branch of the CCSDS Object Identifier Tree, which is specified in [4] as:

```
{ iso-identified-organization(3) standards-producing-organization(112) ccsds(4) css(4)
crossSupportResources(2) crossSupportFunctionalities(1)}
```

Each FR stratum section begins with a table that summarizes the FR sets of that FR stratum and identifies the mapping of the Accessor role, and SAPs, Provided interface and required interfaces to the specific FRs within the FR set that implement those roles, SAPs, and interfaces.

Each FR set section includes a graphical representation of the FRs that comprise that FR set, the relationships among the FRs within the FR set, which FR has the Accessor role, and the assignment of the SAPs and interfaces of the FR set to its component FRs. These diagrams use the following graphical notation to depict the Accessor role, SAP, Provided Interface and Required interface.

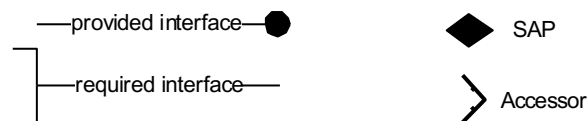

4.1 APERTURE FUNCTIONAL RESOURCE STRATUM

Table 3-1 identifies the port mappings of the current specializations of the Aperture FR Stratum.

Table 4-1: Aperture Functional Resource Sets and Their Associated Accessor, SAP and Interface Mapping

Functional Resource Set	Functional Resource: Accessor Role	Functional Resource: SAPs	Functional Resource: Provided Interface	Functional Resource: Required Interface
RF Aperture	n/a	Antenna: Forward Modulated Waveform Antenna: Return Modulated Waveform	Antenna: Pointing Angles	n/a

4.1.1 RF APERTURE FUNCTIONAL RESOURCE SET OF THE APERTURE FUNCTIONAL RESOURCE STRATUM

The RF Aperture FR set of the Aperture FR stratum consists of the Antenna FR Type. Figure 4-1 illustrates the internal composition of the RF Aperture FR set.

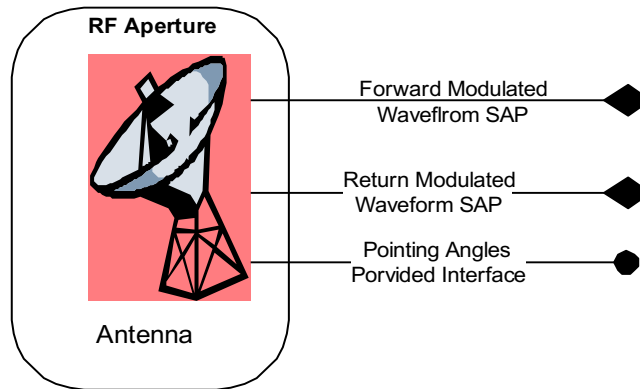

Figure 4-1: Internal Composition of the RF Aperture Functional Resource Set

4.1.1.1 Antenna

The Object Classifier of the Antenna type is antenna.

One antenna can be used by multiple forward and/or return space links simultaneously. The Antenna FR Type also encompasses the tracking receiver used to lock onto the RF signal for the purposes of autotracking.

4.2 FORWARD PHYSICAL CHANNEL ABSTRACT SERVICE COMPONENT

Table 3-2 identifies the port mappings of the current specializations of the Forward Physical Channel Transmission ASC.

Table 4-2: Forward Physical Channel Transmission ASC Service Component Specializations and Their Associated SAP and Accessor Port Mappings

Specialization	Functional Resource: Accessor Port	Functional Resource: SAP Port
CCSDS 401 Forward Physical Channel Transmission.	Forward 401 Space Link Carrier Transmission: Forward Modulated Waveform (essential)	Forward 401 Space Link Carrier Transmission: Forward Physical Channel Symbols (essential) Forward 401 Space Link Carrier Transmission: Transmit Frequency (essential) Forward Link Ranging: Ranging Signal Timing (essential)

4.2.1 CCSDS 401 FORWARD PHYSICAL CHANNEL TRANSMISSION SC SPECIALIZATION OF THE FORWARD PHYSICAL CHANNEL ABSTRACT SERVICE COMPONENT

The FR Types that comprise the CCSDS 401 Forward Physical Channel Transmission SC specialization of the Forward Physical Channel Transmission ASC are:

- a) Forward 401 Space Link Carrier Transmission; and
- b) Forward Link Ranging.

Figure 4-2 illustrates the internal composition of the CCSDS 401 Forward Physical Channel Transmission SC specialization.

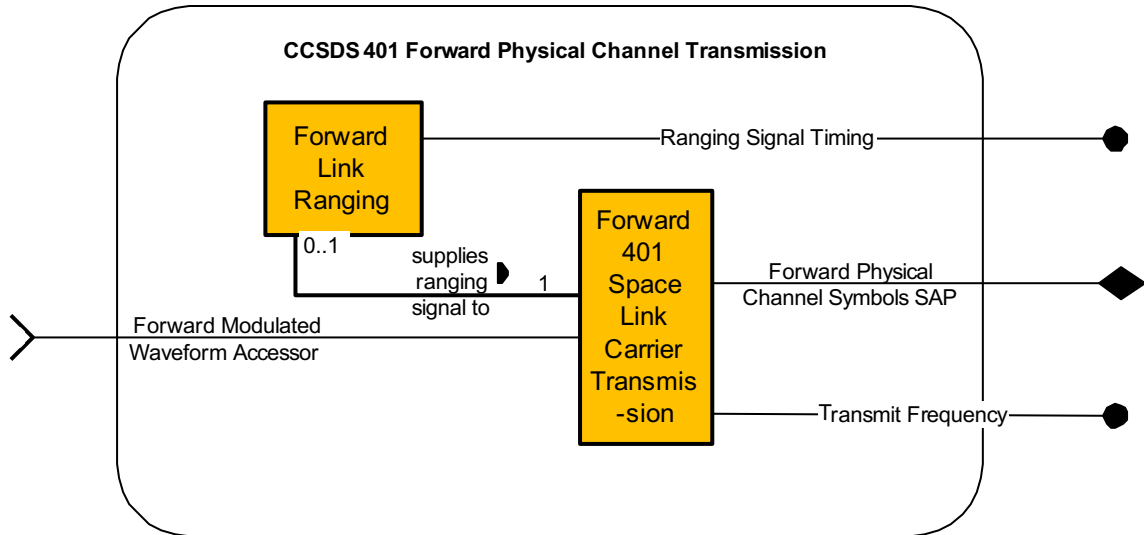

Figure 4-2: Internal Composition of the CCSDS 401 Forward Physical Channel Transmission Service Component

4.2.1.1 Forward 401 Space Link Carrier Transmission

The OID of the Forward 401 Space Link Carrier Transmission FR Type is {crossSupportFunctionalities fwdSpaceLinkCarrierTransmission (2)}.

The Forward 401 Space Link Carrier Transmission FR Type modulates one stream of forward physical channel symbols and/or a ranging signal into a forward electromagnetic waveform.

4.2.1.2 Forward Link Ranging

The OID of the Forward Link Ranging FR Type is {crossSupportFunctionalities fwdLinkRanging (3)}.

The Forward Link Ranging FR Type generates the ranging signal that is applied to the forward physical channel. Depending on the ranging technology used, the ranging signal takes the form of ranging tones as defined in CCSDS 401 (reference [23]), a pseudo-noise (PN) sequence as defined in CCSDS 414 (reference [24]), or a ranging code that is modulated onto the QPSK Q channel of a Code Division Multiple Access (CDMA) spread spectrum forward link as defined in CCSDS 415 (reference [25]). The time of radiation of the ranging signal is provided to the Range and Doppler Extraction FR type so that on reception of the ranging signal replica the round-trip delay can be determined.

4.3 FORWARD SYNCHRONIZATION AND CHANNEL ENCODING ASC

Table 3-3 identifies the port mappings of the current specializations of the Forward Sync and Channel Encoding ASC.

Table 4-3: Forward Sync and Channel Encoding ASC Service Component Specializations and Their Associated SAP and Accessor Port Mappings

Specialization	Functional Resource: Accessor Port	Functional Resource: SAP Port
TC Sync and Channel Encoding	TC Synchronization and Channel Encoding: Forward Physical Channel Symbols (essential) TC Synchronization and Channel Encoding: CLCW (specialization)	TC Synchronization and Channel Encoding: Forward All Transfer Frames (essential) TC Synchronization and Channel Encoding: CLTU (specialization)
AOS Sync and Channel Encoding	AOS Synchronization and Channel Encoding: Forward Physical Channel Symbols (essential)	AOS Synchronization and Channel Encoding: Forward All Transfer Frames (essential) AOS Synchronization and Channel Encoding: Forward AOS CADU (specialization)

4.3.1 FORWARD TC SYNCHRONIZATION AND CHANNEL ENCODING SC SPECIALIZATION OF THE FORWARD SYNCHRONIZATION AND CHANNEL ENCODING ASC

The TC Synchronization and Channel Encoding SC specialization of the Forward Synchronization and Channel Encoding ASC consists of the TC Synchronization and Channel Encoding FR Type. Figure 4-3 illustrates the internal composition of the TC Synchronization and Channel Encoding SC specialization.

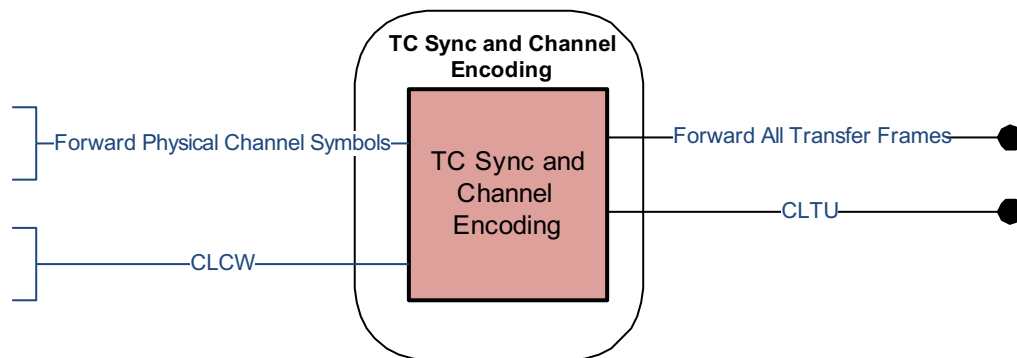

Figure 4-3: Internal Composition of the TC Synchronization and Channel Encoding Service Component

4.3.1.1 TC Synchronization and Channel Encoding

The OID of the TC Synchronization and Channel Encoding FR Type is {crossSupportFunctionalities tcSyncAndChnlEncoding (4)}.

The TC Synchronization and Channel Encoding FR Type corresponds to the following functions:

- a) the Physical Layer Operations Procedure (PLOP) as specified in the TC Synchronization and Channel Coding Recommended Standard; and
- b) the (optional) frame randomization, BCH encoding, and CLTU generation functions specified in the TC Synchronization and Channel Coding Recommended Standard.
- c) The Forward Link Ranging FR type implements the Ranging Signal Timing essential SAP port of the Forward Physical Channel Transmission ASC.

4.3.2 FORWARD AOS SYNCHRONIZATION AND CHANNEL ENCODING SC SPECIALIZATION OF THE FORWARD SYNCHRONIZATION AND CHANNEL ENCODING ASC

The Forward AOS Synchronization and Channel Encoding SC specialization of the Forward Synchronization and Channel Encoding ASC consists of the Forward AOS Synchronization and Channel Encoding FR Type. Figure 4-4 illustrates the internal composition of the TC Synchronization and Channel Encoding SC specialization.

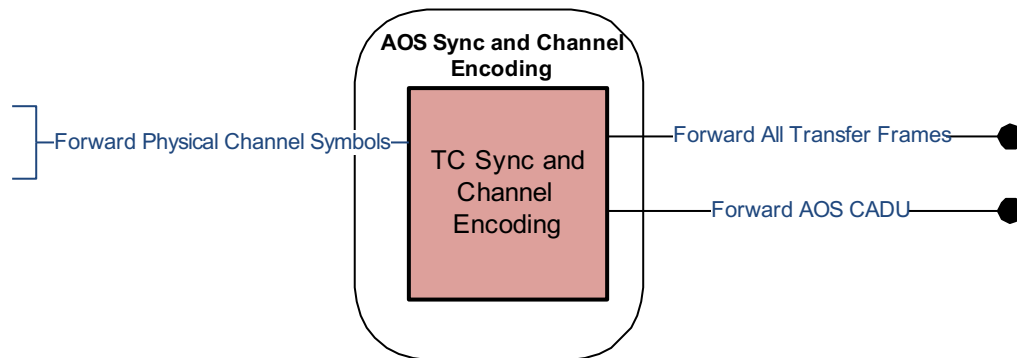

Figure 4-4: Internal Composition of the AOS Synchronization and Channel Encoding Service Component

4.3.2.1 Forward AOS Synchronization and Channel Encoding FR Type

The OID of the Forward AOS Synchronization and Channel Encoding FR Type is {crossSupportFunctionalities fwdAosSyncAndChnlEncoding (5)}.

The Forward AOS Synchronization and Channel Encoding FR Type corresponds to the following functions:

- a) the multiplexing and idle data unit insertion that is nominally specified in the AOS Space Data Link Recommended Standard to be performed on transfer frames. In the

IOAG service set, these functions are performed on already-coded and synch-markered channel access data units (CADUs) instead, in order to provide the CADU mode of the Forward Frames CSTS. The resultant waveform on the space link carrier is the same as that produced by conformance to the AOS Space Data Link Protocol and TM Synchronization and Channel Coding Recommended Standards.; and

- b) the (optional) frame randomization, block (Reed Solomon, Turbo, or LDPC) encoding, frame synchronization marker attachment, and (optional) convolutional encoding functions specified in the TM Synchronization and Channel Coding Recommended Standard.

4.4 FORWARD SPACE LINK PROTOCOL ASC

Table 3-4 identifies the port mappings of the current specializations of the Forward Space Link Protocol Transmission ASC.

Table 4-4: Forward Space Link Protocol Transmission ASC Service Component Specializations and Their Associated SAP and Accessor Port Mappings

Specialization	Functional Resource: Accessor Port	Functional Resource: SAP Port
TC Space Link Protocol Transmission	TC MC Multiplexing: Forward All Transfer Frames (essential) TC Encapsulation, VC Packet Processing and VC Generation: CLCW (specialization)	TC Encapsulation, VC Packet Processing and VC Generation: Forward Packet (essential) Encapsulation and MAP Packet Processing: Forward Packet (essential) TC VC Multiplexing: TC VC Frames (specialization)
Forward AOS Space Link Protocol Transmission	AOS MC Multiplexing: Forward All Transfer Frames (essential)	AOS Encapsulation, Packet Processing and VC Generation: Forward Packet (essential) AOS VC Multiplexing: Forward AOS VC Frames (specialization)

4.4.1 TC SPACE LINK PROTOCOL SPECIALIZATION OF THE FORWARD SPACE LINK PROTOCOL ASC

The FR Types that compose the TC Space Link Protocol specialization of the Forward Space Link Protocol ASC are:

- a) TC Master Channel (MC) Multiplexing;
- b) TC Virtual Channel (VC) Multiplexing;
- c) TC Encapsulation, VC Packet Processing and VC Generation;

- d) Multiplexer Access Point (MAP) Multiplexing; and
- e) Encapsulation and MAP Packet Processing.

Figure 4-5 illustrates the internal composition of the TC Space Link Protocol SC specialization.

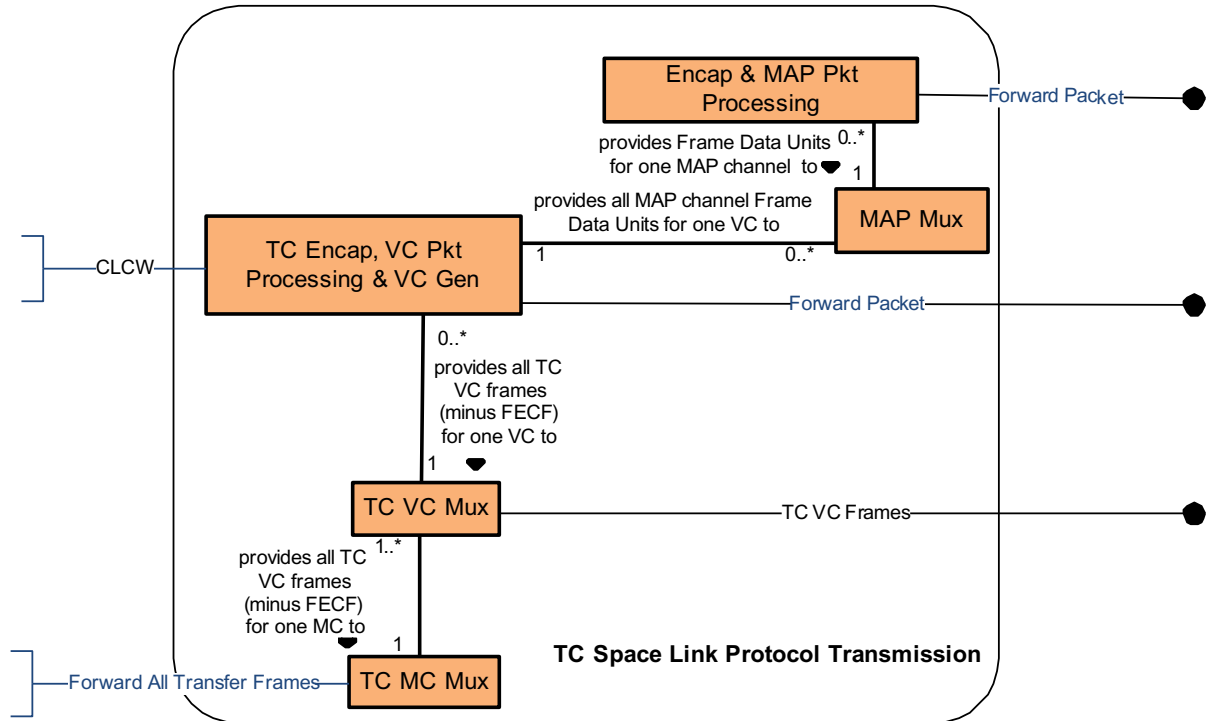

Figure 4-5: Internal Composition of the TC Space Link Protocol Transmission Service Component

4.4.1.1 TC Master Channel (MC) Multiplexing

The OID of the TC MC Multiplexing FR Type is {crossSupportFunctionalities tcMcMux (6)}.

The TC MC Multiplexing FR Type corresponds to the All Frames Generation frame error control function and the MC Multiplexing function of the TC Space Data Link Protocol Recommended Standard.

4.4.1.2 TC Virtual Channel (VC) Multiplexing

The OID of the TC VC Multiplexing FR Type is {crossSupportFunctionalities tcVcMux (7)}.

The TC VC Multiplexing FR Type corresponds to the Virtual Channel Multiplexing function of the TC Space Data Link Protocol Recommended Standard.

4.4.1.3 TC Encapsulation, VC Packet Processing and VC Generation

The OID of the TC Encapsulation, VC Packet Processing and VC Generation FR Type is {crossSupportFunctionalities tcEncapVcPktProcVcGen (8)}.

The TC Encapsulation, VC Packet Processing and VC Generation FR Type corresponds to the following functions:

- a) the Encapsulation function of the Encapsulation Recommended Standard (reference [22]). In this FR Type, the encapsulation occurs directly into TC VCs;

NOTE - The Encapsulation Recommended Standard allows data to be encapsulated in either Space Packets or Encapsulation Packets. The Encapsulation function for this FR Type uses the Encapsulation Packets.

- b) the VC Packet Processing function of the TC Space Data Link Protocol Recommended Standard;
- c) the Virtual Channel Generation function of the TC Space Data Link Protocol Recommended Standard; and
- d) the Frame Operation Procedure-1 (FOP-1) of the Communications Operation Procedure-1 Recommended Standard.

4.4.1.4 Multiplexer Access Point (MAP) Multiplexing

The OID of the MAP Multiplexing FR Type is {crossSupportFunctionalities mapMux (9)}.

The MAP Multiplexing FR Type corresponds to the MAP Multiplexing function of the TC Space Data Link Protocol Recommended Standard.

4.4.1.5 Encapsulation and MAP Packet Processing

The OID of the Encapsulation and MAP Packet Processing FR Type is {crossSupportFunctionalities EncapMapPktProc (10)}.

The Encapsulation and MAP Packet Processing FR Type corresponds to the following functions:

- a) the Encapsulation function of the Encapsulation Recommended Standard (reference [22]). In this FR Type, the encapsulation data are carried by Space Packets through a MAP channel; and
- b) the MAP Packet Processing function of the TC Space Data Link Protocol Recommended Standard.

4.4.2 FORWARD AOS SPACE LINK PROTOCOL SPECIALIZATION OF THE FORWARD SPACE LINK PROTOCOL ASC

The FR Types that compose the Forward AOS Space Link Protocol specialization of the Forward Space Link Protocol ASC are:

- a) AOS MC Multiplexing;
- b) AOS VC Multiplexing; and
- c) AOS Encapsulation, Packet Processing and VC Generation.

Figure 4-6 illustrates the internal composition of the Forward AOS Space Link Protocol Transmission SC specialization.

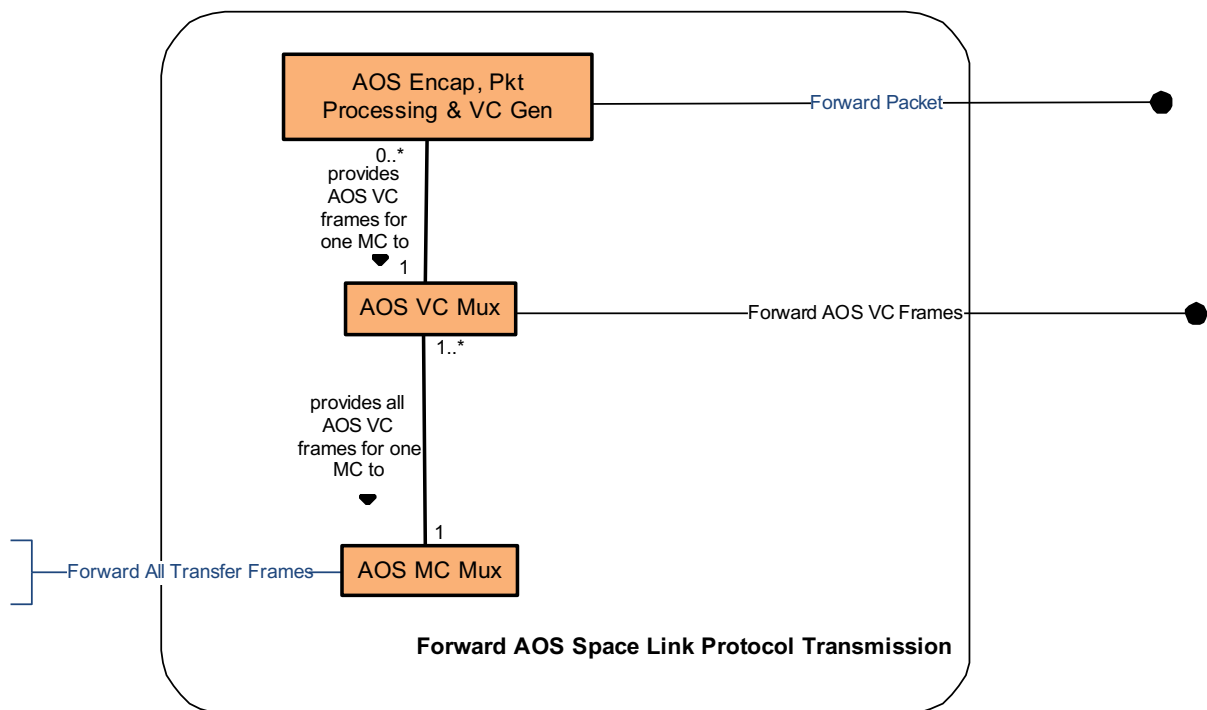

Figure 4-6: Internal Composition of the Forward AOS Space Link Protocol Transmission Service Component

4.4.2.1 AOS MC Multiplexing

The OID of the AOS MC Multiplexing FR Type is {crossSupportFunctionalities aosMcMux (11)}.

The AOS MC Multiplexing FR Type corresponds to the All Frames Generation frame error control function and the MC Multiplexing function of the AOS Space Data Link Protocol Recommended Standard.

NOTE - The AOS All Frames Generation represented by the AOS MC Multiplexing, Channel Synchronization and Encoding FR Type is also the insertion point for Insert service data units. If the Insert SLE transfer service (or an equivalent CSTS) were ever to be implemented, its functionality would be added to the AOS MC Multiplexing and Error Control Functional Resource Type.

4.4.2.2 AOS VC Multiplexing

The OID of the AOS VC Multiplexing FR Type is
{crossSupportFunctionalities aosVcMux (12)}.

The AOS VC Multiplexing FR Type corresponds to the Virtual Channel Multiplexing function of the AOS Space Data Link Protocol Recommended Standard.

4.4.2.3 AOS Encapsulation, Packet Processing and VC Generation

The OID of the AOS Encapsulation, Packet Processing and VC Generation FR Type is
{crossSupportFunctionalities aosEncapPktProcVcGen (13)}.

The AOS Encapsulation, Packet Processing and VC Generation FR Type corresponds to the following functions:

- a) the Encapsulation function of the Encapsulation Recommended Standard. In this FR Type, the encapsulation occurs into AOS VCs;
- b) the Packet Processing function of the AOS Space Data Link Protocol Recommended Standard; and
- c) the Virtual Channel Generation function of the AOS Space Data Link Protocol Recommended Standard.

4.5 RETURN PHYSICAL CHANNEL RECEPTION ASC

Table 3-5 identifies the port mappings of the current specializations of the Return Physical Channel Reception ASC.

**Table 4-5: Return Physical Channel Reception ASC Service Component Specializations
and Their Associated SAP and Accessor Port Mappings**

Specialization	Functional Resource: Accessor Port	Functional Resource: SAP Port
CCSDS 401 Return Physical Channel Reception	Return 401 Space Link Carrier Reception: Return Modulated Waveform (essential) Return 401 Space Link Carrier Reception: Transmit Frequency (essential) Range and Doppler Extraction: Ranging Signal Timing (essential)	Return 401 Space Link Carrier Reception: Return Physical Channel Symbols (essential) Range and Doppler Extraction: Range and Doppler (essential) Return 401 Space Link Carrier Reception: Receive Frequency (essential) Return 401 Space Link Carrier Reception: Analog Waveform (essential) Return 401 Space Link Carrier Reception: DOR Tones (specialization)

4.5.1 CCSDS 401 RETURN PHYSICAL CHANNEL RECEPTION SC SPECIALIZATION OF THE RETURN PHYSICAL CHANNEL RECEPTION ASC

The FR Types that compose the CCSDS 401 Return Physical Channel Reception SC specialization of the Return Physical Channel Reception ASC are:

- a) Return 401 Space Link Carrier Reception; and
- b) Range and Doppler Extraction.

Figure 4-7 illustrates the internal composition of the CCSDS 401 Return Physical Channel Reception SC specialization.

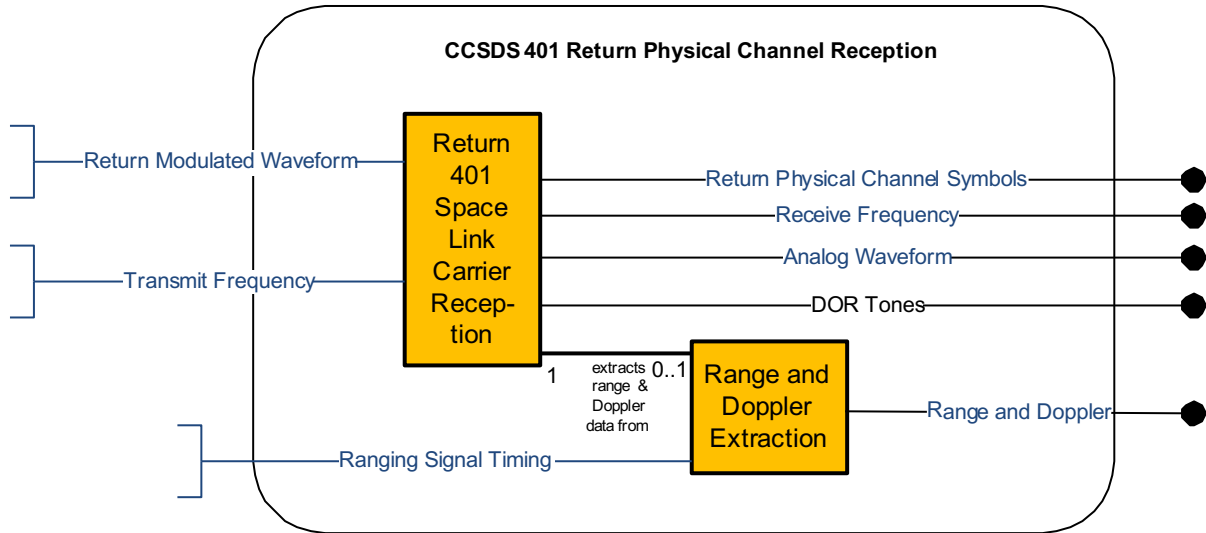

Figure 4-7: Internal Composition of the CCSDS 401 Return Physical Channel Reception Service Component

4.5.1.1 Return 401 Space Link Carrier Reception

The OID of the Return 401 Space Link Carrier Reception FR Type is {crossSupportFunctionalities rtnSpaceLinkCarrierReception (21)}.

The Return 401 Space Link Carrier Reception FR Type demodulates one or two streams of return physical channel symbols and/or a ranging signal from a return electromagnetic waveform.

4.5.1.2 Range and Doppler Extraction

The OID of the Range and Doppler Extraction FR Type is {crossSupportFunctionalities rangeAndDopplerExtraction (22)}.

[Author's Note – a description of how this relates to the relevant CCSDS standards is still needed].

4.6 RETURN SYNCHRONIZATION AND CHANNEL DECODING ASC

Table 3-6 identifies the port mappings of the current specializations of the Return Sync and Channel Decoding ASC.

Table 4-6: Return Sync and Channel Decoding ASC Service Component Specializations and Their Associated SAP and Accessor Port Mappings

Specialization	Functional Resource: Accessor Port	Functional Resource: SAP Port
Return TM Synchronization and Channel Decoding	Return TM Synchronization and Decoding: Return Physical Channel Symbols (essential)	Return TM Synchronization and Decoding: Return All Transfer Frames (essential) Return TM Synchronization and Decoding: Return All Annotated Transfer Frames (specialization)
Telemetry Segmenter	Telemetry Segmenter: Return Physical Channel Symbols (essential)	Telemetry Segmenter: Return All Transfer Frames (essential)

4.6.1 RETURN TM SYNCHRONIZATION AND CHANNEL DECODING SC SPECIALIZATION OF THE RETURN SYNCHRONIZATION AND CHANNEL DECODING ASC

The Return TM Synchronization and Channel Decoding SC specialization of the Return Synchronization and Channel Decoding ASC consists of the Return TM Synchronization and Decoding FR Type. Figure 4-8 illustrates the internal composition of the Return TM Synchronization and Channel Decoding SC specialization.

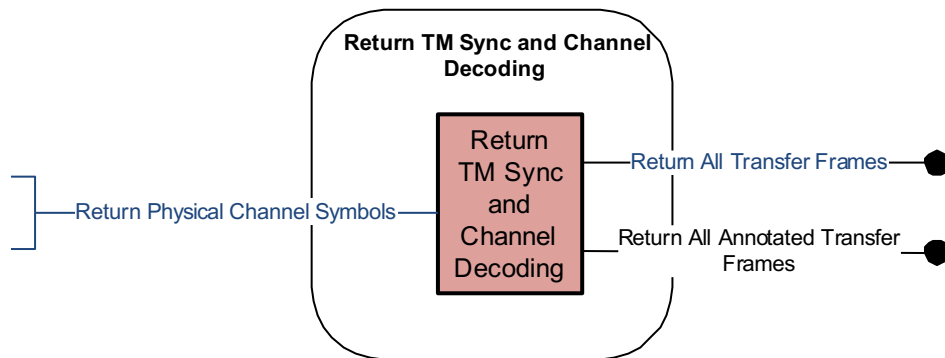

Figure 4-8: Internal Composition of the Return TM Synchronization and Channel Decoding Service Component

4.6.1.1 Return TM Synchronization and Channel Decoding

The OID of the Return TM Synchronization and Channel Decoding FR Type is {crossSupportFunctionalities rtnTmSynchAndDecode (23)}.

The Return TM Synchronization and Decoding FR Type corresponds to the frame synchronization, optional frame de-randomization, block decoding (Reed Solomon, Turbo, or

LDPC), and (optional) convolutional decoding functions specified in the TM Synchronization and Channel Coding Recommended Standard.

The Return TM Synchronization and Decoding FR Type also includes the All Frames Reception function (which performs Frame Error Control decoding) of the TM Space Data Link Protocol and AOS Space Data Link Protocol Recommended Standards.

4.6.2 TELEMETRY SEGMENTER SC SPECIALIZATION OF THE RETURN SYNCHRONIZATION AND CHANNEL DECODING ASC

The Telemetry Segmenter SC specialization of the Return Synchronization and Channel Decoding ASC consists of the Telemetry Segmenter FR Type. Figure 4-9 illustrates the internal composition of the Return TM Synchronization and Channel Decoding SC specialization.

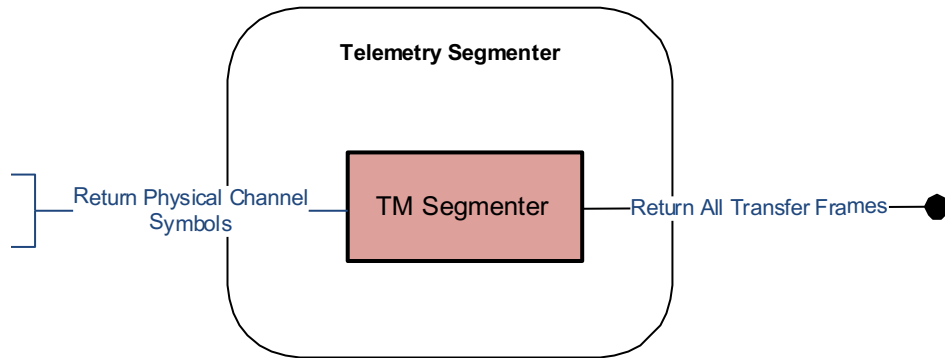

Figure 4-9: Internal Composition of the Telemetry Segmenter Service Component

4.6.2.1 Telemetry Segmenter

The OID of the Telemetry Segmenter FR Type is {crossSupportFunctionalities tlmSegmenter (24)}.

The Telemetry Segmenter constitutes the production functions associated with segmenting unframed telemetry streams for delivery via real-time and complete RUFT CSTS instances.

The Telemetry Segmenter FR Type corresponds to the Telemetry Segmenter production function to be defined in the future RUFT CSTS Recommended Standard.

4.7 RETURN SPACE LINK PROTOCOL RECEPTION ASC

Table 3-7 identifies the port mappings of the current specializations of the Return Space Link Protocol Reception ASC.

Table 4-7: Return Space Link Protocol Reception ASC Service Component Specializations and Their Associated SAP and Accessor Port Mappings

Specialization	Functional Resource: Accessor Port	Functional Resource: SAP Port
Return TM/AOS Space Link Protocol Reception	MC Demultiplexing and Reception: Return All Transfer Frames (essential)	Packet Extraction and De-encapsulation: Return Packet (essential) Packet Extraction and De-encapsulation: CLCW (specialization) VC Demultiplexing and Reception: CLCW (specialization)

4.7.1 RETURN TM/AOS SPACE LINK PROTOCOL RECEPTION SPECIALIZATION OF THE RETURN SPACE LINK PROTOCOL ASC

The FR Types that compose the Return TM/AOS Space Link Protocol Reception specialization of the Return Space Link Protocol Reception ASC are:

- a) MC Demultiplexing and Reception;
- b) VC Demultiplexing and Reception; and
- c) Packet Extraction and De-encapsulation.

Figure 4-10 illustrates the internal composition of the Return TM/AOS Space Link Protocol Reception SC specialization.

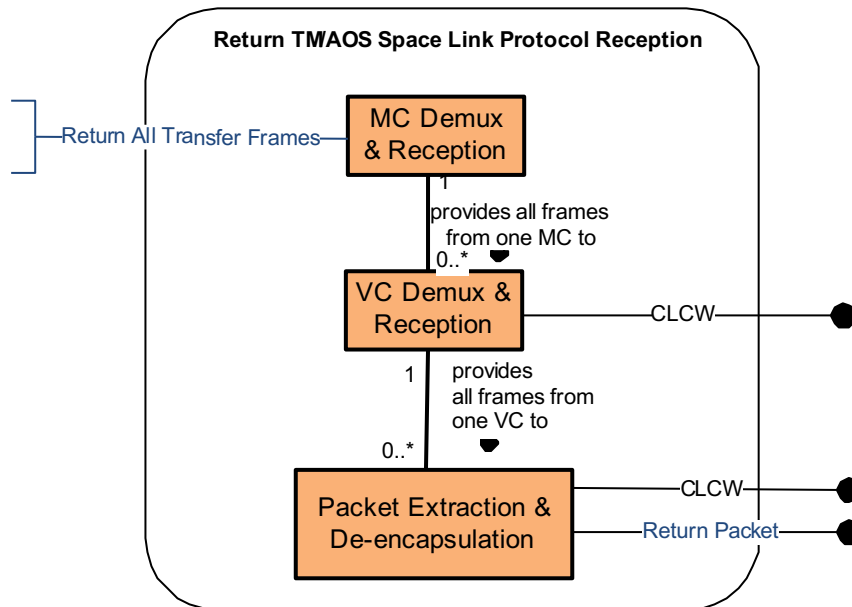

Figure 4-10: Internal Composition of the Return TM/AOS Space Link Protocol Reception Service Component

4.7.1.1 MC Demultiplexing and Reception

The OID of the MC Demultiplexing and Reception FR Type is
{crossSupportFunctionalities mcDemuxAndRcpt (26)}.

The MC Demultiplexing and Reception FR Type corresponds to the MC Reception, and MC Demultiplexing functions of the TM Space Data Link Protocol, and the MC Demultiplexing function of the AOS Space Data Link Protocol Recommended Standards.

NOTE - AOS Space Data Link Protocol Recommended Standard does not include the MC Reception function.

4.7.1.2 VC Demultiplexing and Reception

The OID of the VC Demultiplexing and Reception Type is
{crossSupportFunctionalities vcDemuxAndRcpt (27)}.

The VC Demultiplexing and Reception FR Type corresponds to the VC Demultiplexing and VC Reception functions of the TM Space Data Link Protocol and AOS Space Data Link Protocol Recommended Standards.

4.7.1.3 Packet Extraction and De-encapsulation

The OID of the Packet Extraction and De-encapsulation FR Type is
{crossSupportFunctionalities PktExtractAndDeEncap (28)}.

The Packet Extraction and De-encapsulation FR Type corresponds to the Packet Extraction function of the TM Space Data Link Protocol and AOS Space Data Link Protocol Recommended Standards and the De-encapsulation function of the Encapsulation Service Recommended Standard.

4.8 SLS DATA DELIVERY PRODUCTION ASC

The SLS Data Delivery Production ASC is the Abstract Service Component for FR Types representing production functions that are (a) associated with Data Delivery Transfer Services and (b) performed during a Space Link Session (i.e., during the execution of an SLS Service Package).

Table 3-8 identifies the port mappings of the current specializations of the SLS Data Delivery Production ASC.

Table 4-8: SLS Data Delivery Production ASC Service Component Specializations and Their Associated SAP and Accessor Port Mappings

Specialization	Functional Resource: Accessor Port	Functional Resource: SAP Port
Frame Data Sink	Frame Data Sink: Return All Annotated Transfer Frames (specialization)	Frame Data Sink: Return Selected Transfer Frames (specialization)
Telemetry Segment Sink	Telemetry Segment Sink: Return All Transfer Frames (specialization)	Telemetry Segment Sink: Return All TM Segments (specialization)
Forward File Data Delivery Production	CFDP Sending Entity: Forward Packet (essential) Forward File Service Production: Forward Packet (essential) CFDP Sending Entity: Ack CFDP-PDU (specialization)	Forward File Service Production: Forward Space Data File (specialization)
Return File Data Delivery Production	CFDP Receiving Entity: Return Packet (essential) Return File Service Production: Return Packet (essential)	Return File Service Production: Return Space Data File (specialization) CFDP Receiving Entity: Ack CFDP-PDU (specialization)

4.8.1 FRAME DATA SINK SC SPECIALIZATION OF THE SLS DATA DELIVERY PRODUCTION ASC

The Frame Data Sink SC specialization of the SLS Data Delivery Production ASC consists of the Frame Data Sink FR Type. Figure 4-11 illustrates the internal composition of the Frame Data Sink SC specialization.

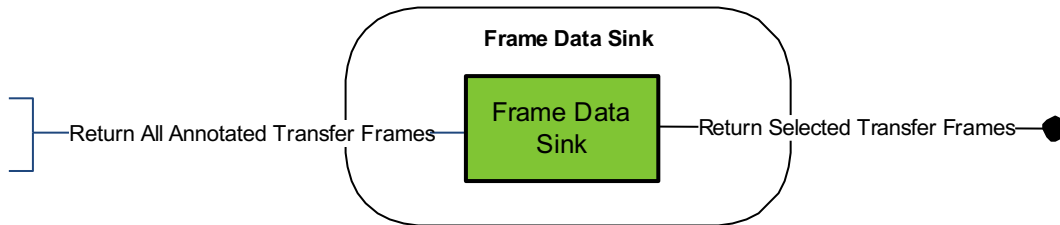

Figure 4-11: Internal Composition of the Frame Data Sink Service Component

4.8.1.1 Frame Data Sink

The OID of the Frame Data Sink FR Type is {crossSupportFunctionalities frameDataSink (29)}.

The Frame Data Sink FR Type comprises the functions performed during the Space Link Session to ensure that return transfer frames are recorded in a specific instance of the Offline Frame Buffer (see 4.10.1.1). Each instance of the Frame Data Sink is tied to (and scheduled as part of) a specific SLS Service Package, whereas the Offline Frame Buffer persists across the execution of multiple SLS Service Packages.

The Frame Data Sink FR Type corresponds to the Frame Data Sink managed object defined in the Space Communication Cross Support Service Management - Service Agreement and Configuration Profile Data Formats Recommended Standard.

4.8.2 TELEMETRY SEGMENT SINK SC SPECIALIZATION OF THE SLS DATA DELIVERY PRODUCTION ASC

The Telemetry Segment Sink SC specialization of the SLS Data Delivery Production ASC consists of the TM Segment Sink FR Type.

NOTE - The Telemetry Segment Sink SC is implemented in conjunction with the Return Unframed Telemetry (RUFT) CSTS.

Figure 4-12 illustrates the internal composition of the Telemetry Segment Sink SC specialization.

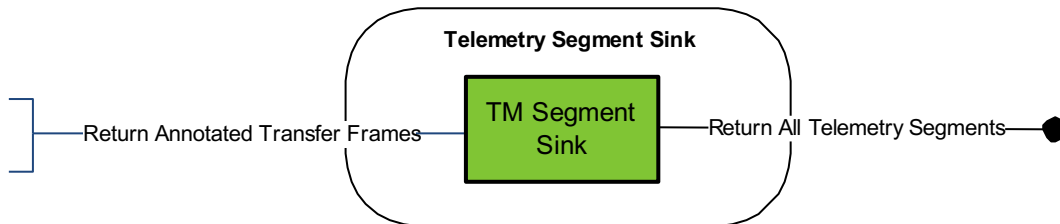

Figure 4-12: Internal Composition of the Telemetry Segment Sink Service Component

4.8.2.1 Telemetry Segment Sink

The OID of the Telemetry Segment Sink FR Type is {crossSupportFunctionalities tlmSegmentSink (30)}.

The Telemetry Segment Sink constitutes the functions performed during the Space Link Session to ensure that unframed telemetry data segments [7] are recorded in a specific instance of the Telemetry Segment Recorded Buffer type.

The Telemetry Segment Sink FR Type corresponds to the Telemetry Segment Sink managed object to be defined in a future version of the Extensible Space Communication Cross Support Service Management Service Specification Recommended Standard.

4.8.3 FORWARD FILE DATA DELIVERY PRODUCTION SC SPECIALIZATION OF THE SLS DATA DELIVERY PRODUCTION ASC

The FR Types that compose the Forward File Data Delivery Production SC specialization of the SLS Data Delivery Production ASC are:

- a) CFDP Sending Entity; and
- b) Forward File Service Production.

Figure 4-13 illustrates the internal composition of the Forward File Data Delivery Production SC specialization.

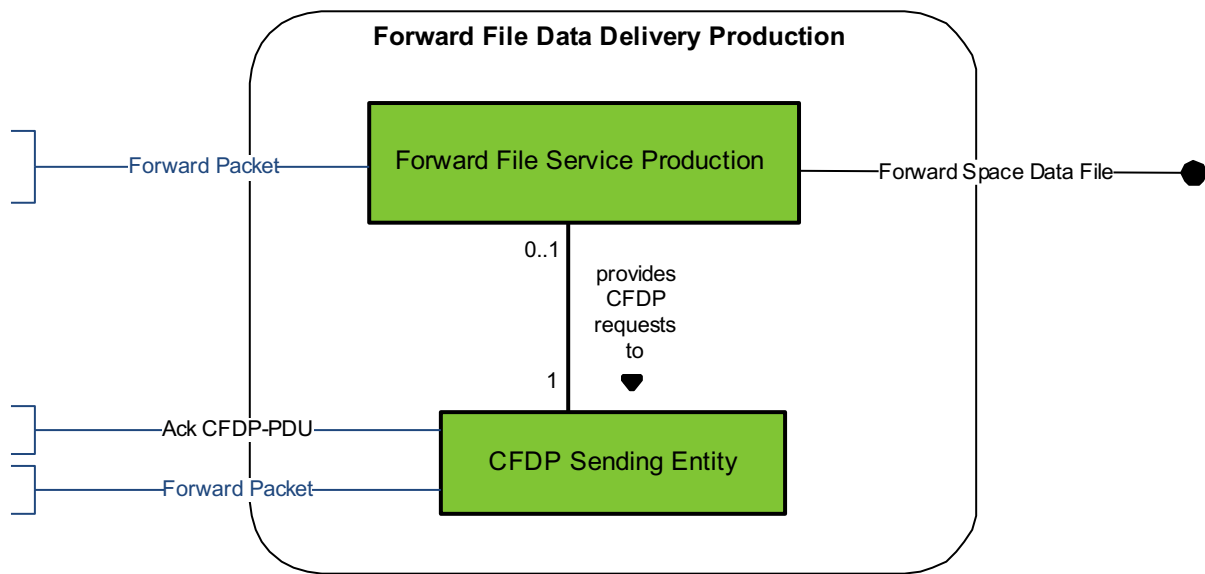

Figure 4-13: Internal Composition of the Forward File Data Delivery Production Service Component

4.8.3.1 CFDP Sending Entity

The OID of the CFDP Sending Entity FR Type is {crossSupportFunctionalities cfdpSendEntity (17)}.

The CFDP Sending Entity FR Type corresponds to the Sending Entity Core Delivery procedures of the CFDP Recommended Standard (reference [26]).

4.8.3.2 Forward File Service Production

The OID of the Forward File Service Production FR Type is {crossSupportFunctionalities fwdFileSvcProd (18)}.

The Forward File Service Production FR Type corresponds to the SLS production functions of the future Forward File Data Delivery Service. Because this service is not yet defined, these production functions have not yet been formally identified, but conceptually they deal with

- a) Extracting the file from the Forward File Data Store at the time that they are to be transmitted across the forward space link; and
- b) Sending the file using the protocols that have been specified for that file transmission (e.g., in Space Packets, in Encapsulation Packet, over CFDP).

4.8.4 RETURN FILE SC SPECIALIZATION OF THE SLS DATA DELIVERY PRODUCTION ASC

The FR Types that compose the Return File SC specialization of the SLS Data Delivery Production ASC are:

- a) CFDP Receiving Entity; and
- b) Return File Service Production.

Figure 4-14 illustrates the internal composition of the Return File Data Delivery Production SC specialization.

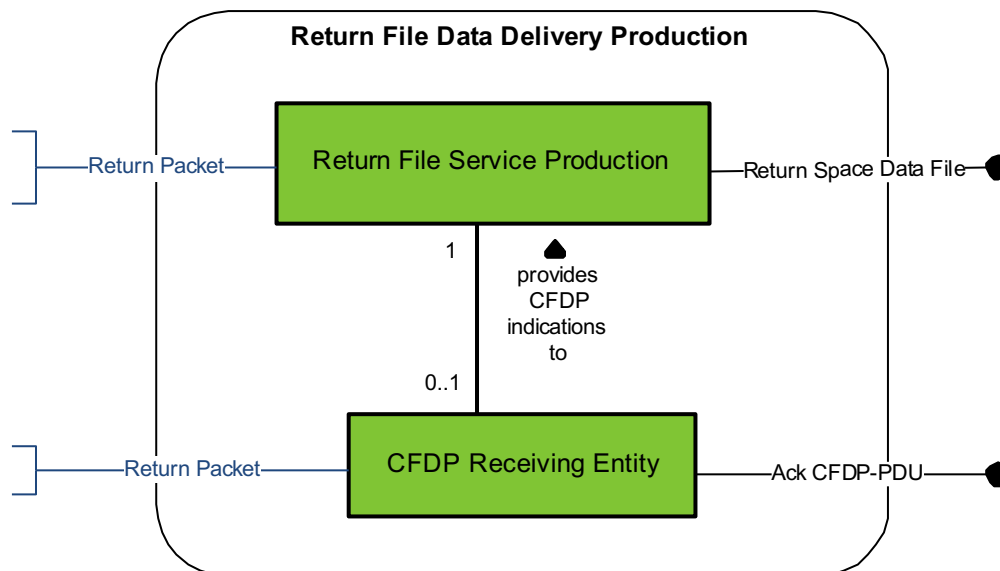

Figure 4-14: Internal Composition of the Return File Data Delivery Production Service Component

4.8.4.1 CFDP Receiving Entity

The OID of the CFDP Receiving Entity FR Type is {crossSupportFunctionalities cfdpSendEntity (37)}.

The CFDP Receiving Entity FR Type corresponds to the Receiving Entity Core Delivery procedures of the CFDP Recommended Standard (reference [26]).

4.8.4.2 Return File Service Production

The OID of the Return File Service Production FR Type is {crossSupportFunctionalities rtnFileSvcProd (38)}.

DRAFT TECHNICAL NOTE CONCERNING THE FUNCTIONAL RESOURCE REFERENCE
MODEL

The Return File Service Production FR Type corresponds to the SLS production functions of the future Return File Data Delivery Service. Because this service is not yet defined, these production functions have not yet been formally identified, but conceptually they deal with

- a) Receiving the file using the protocols that have been specified for that file reception (e.g., in Space Packets, in Encapsulation Packet, over CFDP); and
- b) Placing the file in the Return File Data Store for subsequent retrieval using the Terrestrial File Transfer Service.

4.9 SLS RADIOMETRIC DATA PRODUCTION ASC

Table 3-9 identifies the port mappings of the current specializations of the SLS Radiometric Data Production ASC.

Table 4-9: SLS Radiometric Data Production ASC Service Component Specializations and Their Associated SAP and Accessor Port Mappings

Specialization	Functional Resource: Accessor Port	Functional Resource: SAP Port
Real-Time Radiometric Data Collection	TDM Segment Generation: Range and Doppler (essential) TDM Segment Generation: Receive Frequency (essential) TDM Segment Generation: Transmit Frequency (essential) TDM Segment Generation: Pointing Angles (specialization)	TDM Segment Generation: TDM Segments (specialization) TDM Sink: TDM Segments (specialization)
Non-Validated Radiometric Data Collection	Non-validated Radiometric Data Collection: Range and Doppler (essential) Non-validated Radiometric Data Collection: Receive Frequency (essential) Non-validated Radiometric Data Collection: Transmit Frequency (essential) Non-validated Radiometric Data Collection: Pointing Angles (specialization)	Non-validated Radiometric Data Collection: Pre-Validated Radiometric Data (specialization)

Specialization	Functional Resource: Accessor Port	Functional Resource: SAP Port
Delta-DOR Raw Data Collection	D-DOR Raw Data Collection: DOR Tones (specialization).	D-DOR Raw Data Collection: Raw-formatted D-DOR Data (specialization)
Open Loop Receiver/Formatter	Open Loop Receiver/Formatter: Analog Waveform (specialization).	Open Loop Receiver/Formatter: Formatted Open Loop Data (specialization)

4.9.1 REAL-TIME RADIOMETRIC DATA COLLECTION SC SPECIALIZATION OF THE SLS RADIOMETRIC DATA PRODUCTION ASC

The FR Types that compose the Real-Time Radiometric Data Collection specialization of the SLS Radiometric Data Production ASC are:

- a) TDM Segment Generation; and
- b) TDM Sink.

Figure 4-15 illustrates the internal composition of the Real-Time Radiometric Data Collection SC specialization.

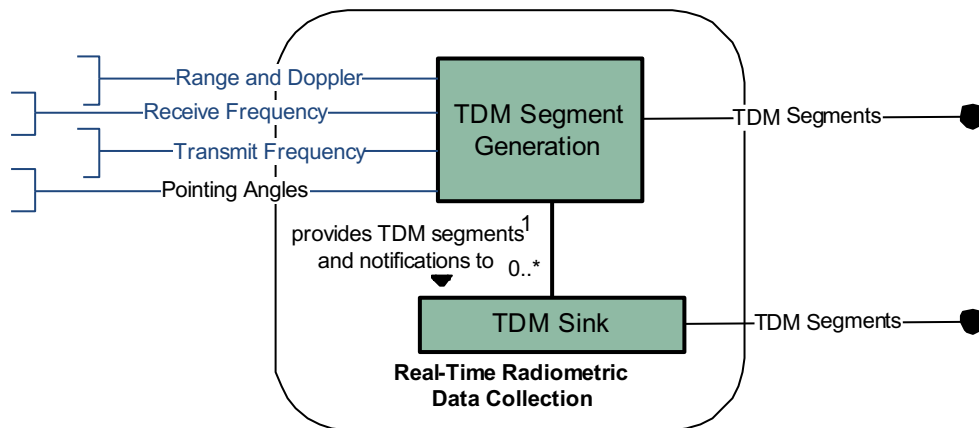

Figure 4-15: Internal Composition of the Real-Time Radiometric Data Collection Service Component

4.9.1.1 TDM Segment Generation

The OID of the TDM Segment Generation FR Type is {crossSupportFunctionalities tdmSegmentGen (40)}.

TDM Segment Generation constitutes the production functions associated with collecting angle measurements from the antenna, receive frequency and Doppler measurements from the return space link, range measurements from the forward and return space links, and

transmit frequency from the forward space link in order to generate Tracking Data Message (TDM) segments containing those measurements.

The TDM Segment Generation FR Type corresponds to the TDM Segment Generation production functions defined in the draft Tracking Data CSTS Recommended Standard (reference [8]).

4.9.1.2 TDM Sink

The OID of the TDM Sink FR Type is {crossSupportFunctionalities tdmSink (41)}.

The TDM Sink constitutes the functions performed during the Space Link Session to ensure that TDM segments [8] are recorded in a specific instance of the Tracking Data Recording Buffer type.

The TDM Sink FR Type corresponds to the TDM Sink managed object to be defined in the future *Space Communication Cross Support Service Management - Service Agreement and Configuration Profile Data Formats* Recommended Standard.

4.9.2 NON-VALIDATED RADIOMETRIC DATA COLLECTION SC SPECIALIZATION OF THE SLS RADIOMETRIC DATA PRODUCTION ASC

The Non-validated Radiometric Data Collection SC specialization of the SLS Radiometric Data Production ASC consists of the Non-validated Radiometric Data Collection FR Type. Figure 4-16 illustrates the internal composition of the Non-validated Radiometric Data Collection SC specialization.

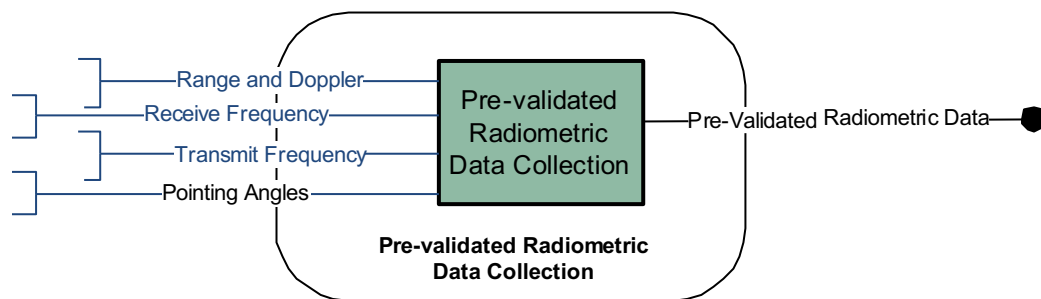

Figure 4-16: Internal Composition of the Non-validated Radiometric Data Collection Service Component

4.9.2.1 Non-validated Radio Metric Data Collection

The OID of the Non-validated Radiometric Data Collection FR Type is {crossSupportFunctionalities nonValRmDataCollect (48)}.

non-validated Radiometric Data Collection constitutes the production functions associated with the collection of raw radiometric data during a space link session.

NOTE - The radiometric validation process involves analyst interaction and is therefore not performed during the space link session. The performance of radiometric data validation is outside the scope of SCCS-SM.

4.9.3 DELTA-DOR RAW DATA COLLECTION SC SPECIALIZATION OF THE SLS RADIOMETRIC DATA PRODUCTION ASC

The Delta-DOR Raw Data Collection SC specialization of the SLS Radiometric Data Production ASC consists of the Delta-DOR Raw Data Collection FR Type. Figure 4-17 illustrates the internal composition of the Delta-DOR Raw Data Collection SC specialization.

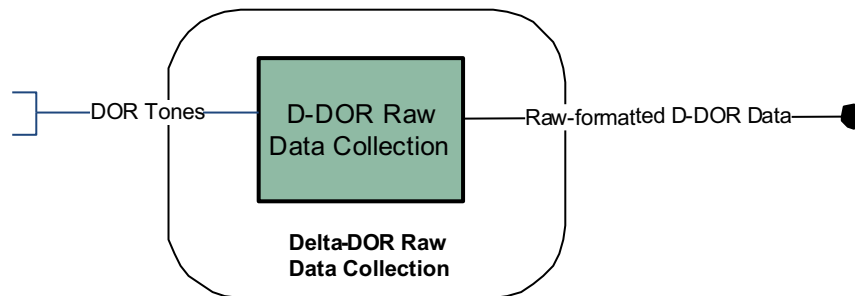

Figure 4-17: Internal Composition of the Delta-DOR Raw Data Collection Service Component

4.9.3.1 D-DOR Raw Data Collection

The OID of the D-DOR Raw Data Collection FR Type is {crossSupportFunctionalities dDorRawDataCollect (46)}.

D-DOR Raw Data Collection consists of the production functions associated with collecting the D-DOR raw data samples and organizing them in the standard D-DOR Raw Data file format (reference [32]) for storage.

4.9.4 OPEN LOOP RECEIVER/FORMATTER SC SPECIALIZATION OF THE SLS RADIO METRIC DATA PRODUCTION ASC

The Open Loop Receiver/Formatter SC specialization of the SLS Radiometric Data Production ASC consists of the Open Loop Receiver/Formatter FR Type. Figure 4-18 illustrates the internal composition of the Open Loop Receiver/Formatter SC specialization.

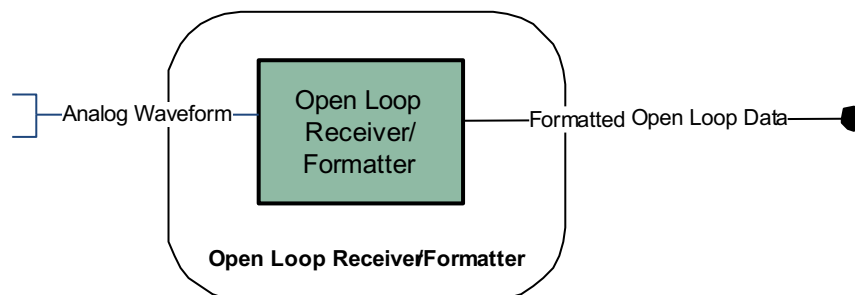

Figure 4-18: Internal Composition of the Open Loop Receiver/Formatter Service Component

4.9.4.1 Open Loop Receiver/Formatter

The OID of the Open Loop Receiver/Formatter FR Type is {crossSupportFunctionalities openLoopReceiver (44)}.

The Open Loop Receiver/Formatter constitutes the functions performed during the Space Link Session to receive the open loop signal of the return link, digitize the signal, and route the resulting data to a specific instance of the Open Loop Data Store type.

The Open Loop Receiver/Formatter FR Type corresponds to the Open Loop Receiver/Formatter managed object to be defined in the *Space Communication Cross Support Service Management - Service Agreement and Configuration Profile Data Formats Recommended Standard Recommended Standard*.

4.10 OFFLINE DATA STORAGE ASC

The Offline Data Storage ASC is the ASC for FR Types representing data storage functions that store forward link data for subsequent transmission during a Space Link Session and that store telemetry received during a Space Link Session for subsequent retrieval via offline or complete data delivery transfer services.

Table 3-10 identifies the port mappings of the current specializations of the Offline Data Storage ASC.

Table 4-10: Offline Data Storage ASC Service Component Specializations and Their Associated SAP and Accessor Port Mappings

Specialization	Functional Resource: Accessor Port	Functional Resource: SAP Port
Offline Frame Buffer	Offline Frame Buffer: Return Selected Transfer Frames (specialization)	Offline Frame Buffer: Return All Buffered Transfer Frames (specialization)
TM Segment Recording Buffer	Telemetry Segment Recording Buffer: Return All TM Segments (specialization)	Telemetry Segment Recording Buffer: Return Buffered TM Segments (specialization)
Forward File Data Store	Forward File Data Store: Forward Space Data File (specialization)	Forward File Data Store: Forward File (specialization)
Return File Data Store	Return File Data Store: Return Space Data File (specialization)	Return File Data Store: Return File (specialization)

DRAFT TECHNICAL NOTE CONCERNING THE FUNCTIONAL RESOURCE REFERENCE MODEL

Specialization	Functional Resource: Accessor Port	Functional Resource: SAP Port
TDM Segment Recording Buffer	TDM Recording Buffer: TDM Segments (specialization)	TDM Recording Buffer: Buffered TDM Segments (specialization)
Non-Validated Radiometric Data Store	Non-Validated Radiometric Data Store: Non-Validated Radiometric Data (specialization)	n/a
Validated Radiometric Data Store	n/a	Validated Radiometric Data Store: Return File (specialization)
Delta-DOR Raw Data Store	Delta-DOR Raw Data Store: Raw-formatted D-DOR Data (specialization)	Delta-DOR Raw Data Store: Return File (specialization)
Open Loop Data Store	Open Loop Data Store: Formatted Open Loop Data	Open Loop Data Store: Return File (specialization)

4.10.1 OFFLINE FRAME BUFFER SC SPECIALIZATION OF THE OFFLINE DATA DELIVERY PRODUCTION ASC

The Offline Frame Buffer specialization of the Offline Data Storage ASC consists of the Offline Frame Buffer FR Type. Figure 4-19 illustrates the internal composition of the Offline Frame Buffer SC specialization.

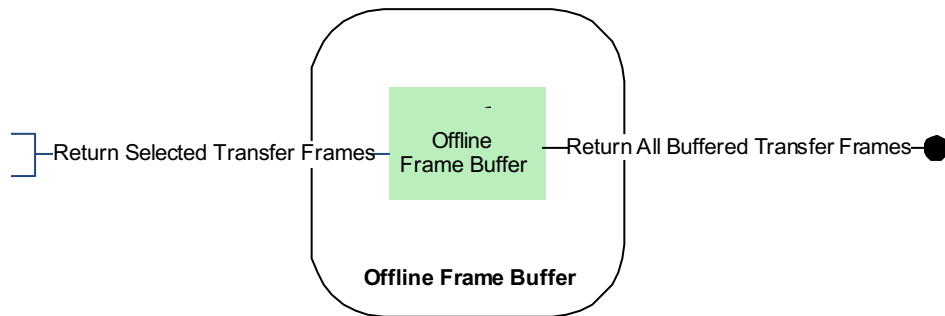

Figure 4-19: Internal Composition of the Offline Frame Buffer Service Component

4.10.1.1 Offline Frame Buffer

The OID of the Offline Frame Buffer FR Type is {crossSupportFunctionalities offlFrameBuffer (31)}.

The Offline Frame Buffer is a repository of return transfer frames that are subsequently retrieved by offline SLE transfer service instances that carry transfer frames or space link data units that have been transferred across the space link within those transfer frames.

The Offline Frame Buffer FR Type corresponds to the Offline Frame Buffer production entity defined in the SLE RAF and RCF Service Specification Recommended Standard.

NOTE - The Offline Frame Buffer for a given physical channel symbol stream may be shared by multiple offline RAF TS and/or Return Channel Frame TS service instances.

4.10.2 TELEMETRY SEGMENT RECORDING BUFFER SC SPECIALIZATION OF THE OFFLINE DATA STORAGE ASC

The Telemetry Segment Recording Buffer SC specialization of the Offline Storage Production ASC consists of the Telemetry Segment Recording Buffer FR Type.

NOTE - The Telemetry Segment Recording Buffer SC is implemented in conjunctions with the Return Unframed Telemetry CSTS.

Figure 4-20 illustrates the internal composition of the Telemetry Segment Recording Buffer SC specialization.

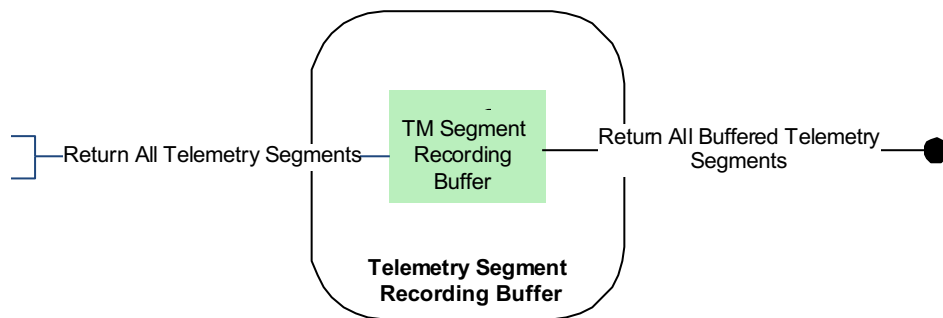

Figure 4-20: Internal Composition of the Telemetry Segment Recording Buffer Service Component

4.10.2.1 Telemetry Segment Recording Buffer

The OID of the Telemetry Segment Recording Buffer FR Type is {crossSupportFunctionalities tlmSegmentRcrdBuffer (32)}.

The Telemetry Segment Recording Buffer is a repository of unframed data segments that are subsequently retrieved by complete RUFT CSTS instances.

The Telemetry Segment Recording Buffer FR Type corresponds to the Recording Buffer production entity to be defined in the future RUFT CSTS Recommended Standard.

4.10.3 FORWARD FILE DATA STORE SC SPECIALIZATION OF THE OFFLINE DATA STORAGE ASC

The Forward File Data Store SC specialization of the Offline Data Storage ASC consists of the Forward File Data Store FR Type. Figure 4-21 illustrates the internal composition of the Forward File Data Store SC specialization.

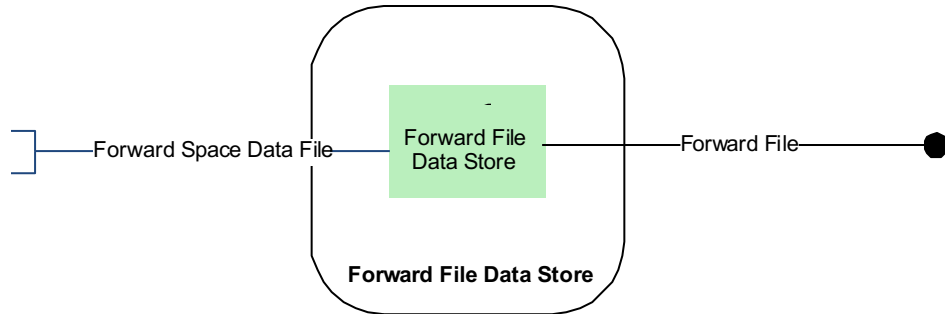

Figure 4-21: Internal Composition of the Forward File Data Store Service Component

4.10.3.1 Forward File Data Store

The OID of the Forward File Data Store FR Type is {crossSupportFunctionalities fwdFileDataStore (19)}.

The Forward File Data Store is the repository of space data files that are transmitted across the space link as part for the Forward File Service.

4.10.4 RETURN FILE DATA STORE SC SPECIALIZATION OF THE OFFLINE DATA STORAGE ASC

The Return File Data Store SC specialization of the Offline Data Storage ASC consists of the Return File Data Store FR Type. Figure 4-22 illustrates the internal composition of the Return File Data Store SC specialization.

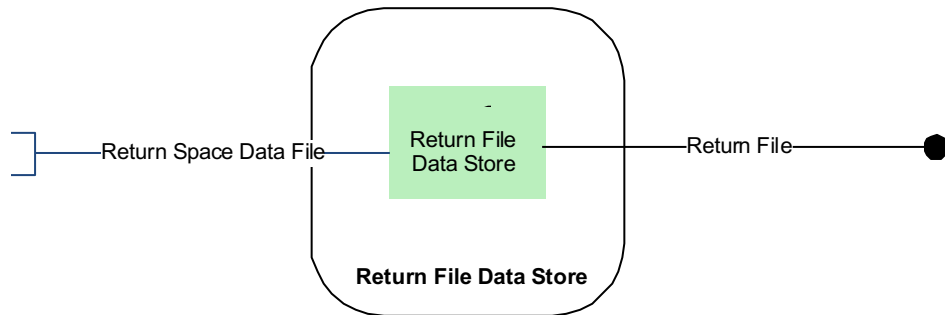

Figure 4-22: Internal Composition of the Return File Data Store Service Component

4.10.4.1 Return File Data Store

The OID of the Return File Data Store FR Type is {crossSupportFunctionalities rtnFileDataStore (39)}.

The Return File Server FR Type corresponds to the functions to be specified in a future Return File Service Specification Recommended Standard.

4.10.5 TRACKING DATA MESSAGE (TDM) RECORDING BUFFER SC SPECIALIZATION OF THE OFFLINE DATA STORAGE ASC

The TDM Recording Buffer SC specialization of the Offline Data Storage ASC consists of the TDM Recording Buffer FR Type. Figure 4-23 illustrates the internal composition of the TDM Recording Buffer SC specialization.

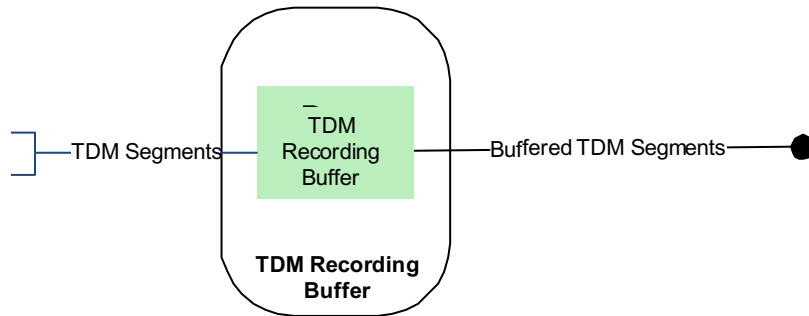

Figure 4-23: Internal Composition of the TDM Recording Buffer Service Component

4.10.5.1 TDM Recording Buffer

The OID of the TDM Recording Buffer FR Type is {crossSupportFunctionalities tdmRcrdBuffer (42)}.

The TDM Recording Buffer is a repository of tracking data segments that are subsequently retrieved by Complete Tracking Data CSTS Provider instances

The TDM Recording Buffer FR Type corresponds to the Recording Buffer production entity defined in the Draft Tracking Data CSTS Recommended Standard.

4.10.6 NON-VALIDATED RADIOMETRIC DATA STORE SC SPECIALIZATION OF THE OFFLINE DATA STORAGE ASC

The Non-validated Radiometric Data Store SC specialization of the Offline Data Storage ASC consists of the Non-validated Radiometric Data Store FR Type Figure 4-24 illustrates the internal composition of the Pre-validated Radiometric Data Store SC specialization.

NOTE - The Non-validated Radiometric Data Store has no SAP port, because there is no Service Component or functional resource that connects to it in any automated way for the purposes of acquiring the contents of the data store. The radiometric data validation process is a manual process that culminates in the creation of a validated radiometric dataset in a validated radiometric data store (see 4.10.7.14.10.7).

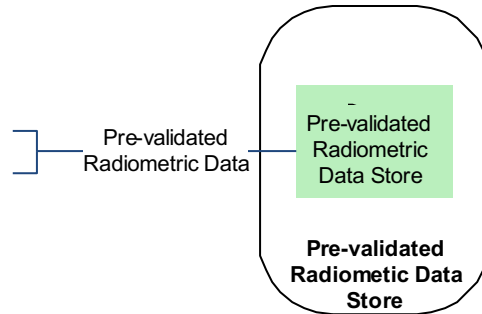

Figure 4-24: Internal Composition of the Non-validated Radiometric Data Store Service Component

4.10.6.1 Non-validated Radiometric Data Store

The OID of the Non-validated Radiometric Data Store FR Type is {crossSupportFunctionalities nonValRmDataStore (49)}.

The Non-validated Radiometric Data Store constitutes a repository of raw radiometric data that is awaiting validation processing.

4.10.7 VALIDATED RADIOMETRIC DATA STORE SC SPECIALIZATION OF THE OFFLINE DATA STORAGE ASC

The Validated Radiometric Data Store SC specialization of the Offline Data Storage ASC consists of the Validated Radiometric Data Store FR Type. Figure 4-25 illustrates the internal composition of the Validated Radiometric Data Store SC specialization.

NOTE - The Validated Radiometric Data Store has no Accessor port, because there is no Service Component or functional resource that connects to it in any automated way to be the source of the data. The radiometric data validation process is a manual process that transforms pre-validated radiometric data (see 4.10.6) culminates into a validated radiometric dataset.

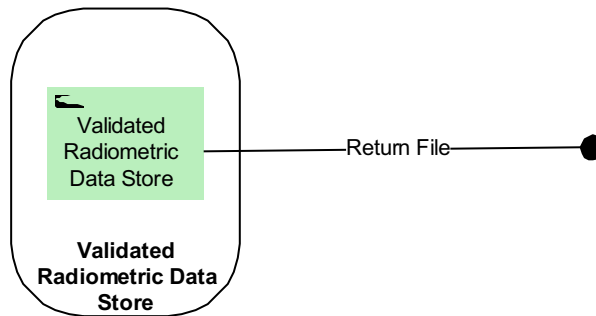

Figure 4-25: Internal Composition of the Validated Radiometric Data Store Service Component

4.10.7.1 Validated Radiometric Data Store

The OID of the Validated Radiometric Data Store FR Type is {crossSupportFunctionalities valRmDataStore (50)}.

The Validated Radiometric Data Store constitutes a repository of radiometric data that has undergone validation processing and is awaiting retrieval via the Terrestrial File Transfer Service.

4.10.8 D-DOR RAW DATA STORE SC SPECIALIZATION OF THE OFFLINE DATA STORAGE ASC

The D-DOR Raw Data Store SC specialization of the Offline Data Storage ASC consists of the D-DOR Raw Data Store FR Type. Figure 4-26 illustrates the internal composition of the D-DOR Raw Data Store SC specialization.

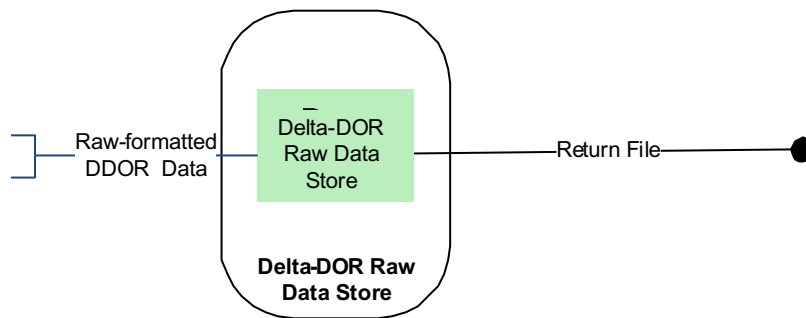

Figure 4-26: Internal Composition of the D-DOR Raw Data Store Service Component

4.10.8.1 D-DOR Raw Data Store

The OID of the D-DOR Raw Data Store FR Type is {crossSupportFunctionalities dDorRawDataStore (47)}.

The D-DOR Raw Data Store constitutes the repository of D-DOR raw data samples that have been organized in the standard D-DOR Raw Data format. D-DOR raw data stored in the D-DOR Raw Data Store is retrieved via the Terrestrial File Transfer Service.

4.10.9 OPEN LOOP DATA STORE SC SPECIALIZATION OF THE OFFLINE DATA STORAGE ASC

The Open Loop Data Store SC specialization of the Offline Data Storage ASC consists of the Open Loop Data Store FR Type. Figure 4-27 illustrates the internal composition of the Open Loop Data Store SC specialization.

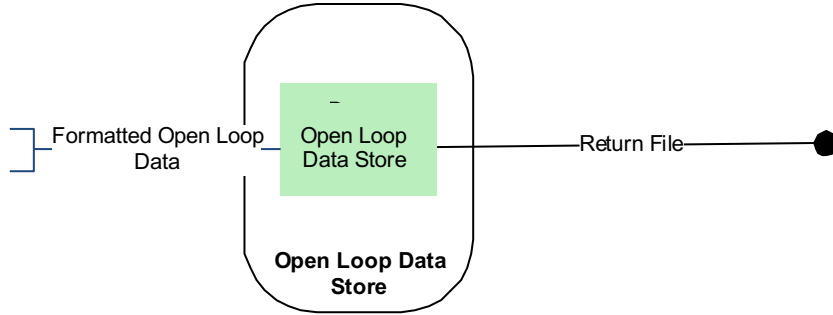

Figure 4-27: Internal Composition of the Open Loop Data Store Service Component

4.10.9.1 Open Loop Data Store

The OID of the Open Loop Data Store FR Type is {crossSupportFunctionalities openLoopDataStore (45)}.

The Open Loop Data Store is a repository of open loop data acquired by an Open Loop Receiver. The format of the open loop data is proprietary to the service provider. Open Loop data stored in the Open Loop Data Store is retrieved via the Terrestrial File Transfer Service.

4.11 DATA TRANSFER SERVICES ASC

Table 3-11 identifies the port mappings of the current specializations of the Data Transfer Services ASC.

Table 4-11: Data Transfer Services ASC Service Component Specializations and Their Associated Accessor Port Mappings

Specialization	Functional Resource: Accessor Port
SLE Forward Space Packet	F-SP Transfer Service Provider: Forward Packet (specialization)
SLE Forward CLTU	F-CLTU Transfer Service Provider: CLTU (specialization)
Forward Frame CSTS	Forward Frame CSTS Provider: TC VC Frames (specialization). Forward Frame CSTS Provider: Forward AOS VC Frames (specialization). Forward Frame CSTS Provider: Forward AOS CADU (specialization)
Terrestrial File Transfer Service	Terrestrial File Transfer Service Provider: Forward File (specialization) Terrestrial File Transfer Service Provider: Return File (specialization)
SLE Return All Frames	RAF TS Provider: Return All Annotated Transfer Frames (specialization). RAF TS Provider: Return All Buffered Transfer Frames (specialization)

Specialization	Functional Resource: Accessor Port
SLE Return Channel Frames	RCF TS Provider: Return All Annotated Transfer Frames (specialization) RCF TS Provider: Return All Buffered Transfer Frames (specialization)
SLE ROCF	ROCF TS Provider: Return All Annotated Transfer Frames (specialization)
Return Unframed Telemetry (RUFT)	RUFT CSTS Provider: Return All Transfer Frames (specialization) RUFT CSTS Provider: Return Buffered Unframed Telemetry Segments (specialization)
Tracking Data CSTS	Tracking Data CSTS Provider: TDM Segments (specialization) Tracking Data CSTS Provider: Buffered TDM Segments (specialization)

4.11.1 SLE FORWARD SPACE PACKET SPECIALIZATION OF THE DATA TRANSFER SERVICES ASC

The SLE Forward Space Packet (F-SP) SC specialization of the Data Transfer Service ASC consists of the F-SP Transfer Service Provider FR Type. Figure 4-28 illustrates the internal composition of the SLE Forward Space Packet SC specialization.

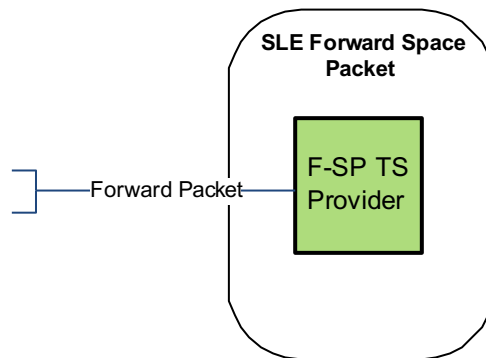

Figure 4-28: Internal Composition of the SLE Forward Space Packet Service Component

4.11.1.1 F-SP Transfer Service Provider

The OID of the FSP TS Provider FR Type is {crossSupportFunctionalities fspTsProvider (16)}.

The FSP TS Provider FR Type corresponds to the functions specified in the SLE Forward Space Packet Service Specification Recommended Standard (reference [28]).

4.11.2 SLE FORWARD CLTU SC SPECIALIZATION OF THE DATA TRANSFER SERVICES ASC

The SLE Forward CLTU SC specialization of the Data Transfer Services ASC consists of the F-CLTU Transfer Service Provider FR Type. Figure 4-29 illustrates the internal composition of the SLE Forward CLTU SC specialization.

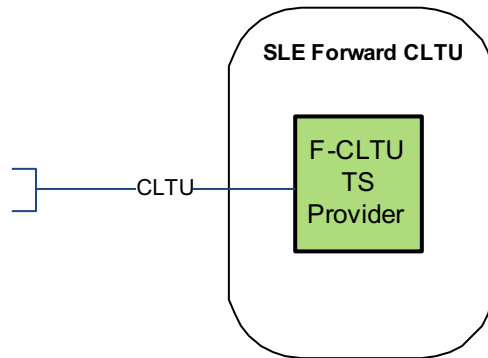

Figure 4-29: Internal Composition of the SLE Forward CLTU Service Component

4.11.2.1 F-CLTU Transfer Service Provider

The OID of the FCLTU TS Provider FR Type is {crossSupportFunctionalities fcltuTsProvider (14)}.

The FCLTU TS Provider FR Type corresponds to the functions specified in the SLE Forward CLTU Service Specification Recommended Standard (reference [27]).

4.11.3 FORWARD FRAMES CSTS SC SPECIALIZATION OF THE DATA TRANSFER SERVICES ASC

The Forward Frames CSTS SC specialization of the Data Transfer Services ASC consists of the Forward Frames CSTS Provider FR Type. Figure 4-30 illustrates the internal composition of the Forward Frames CSTS SC specialization.

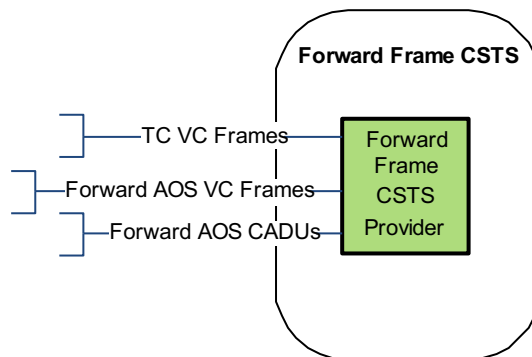

Figure 4-30: Internal Composition of the Forward Frames CSTS Service Component

4.11.3.1 Forward Frames CSTS Provider

The OID of the Forward Frames CSTS Provider FR Type is {crossSupportFunctionalities fwdFramesCstsProvider (15)}.

The Forward Frame CSTS Provider FR Type corresponds to the functions to be specified in a future Forward Frame CSTS Specification Recommended Standard.

4.11.4 TERRESTRIAL FILE TRANSFER SC SPECIALIZATION OF THE DATA TRANSFER SERVICES ASC

The Terrestrial File Transfer SC specialization of the Data Transfer Services ASC consists of the Terrestrial File Transfer Service Provider FR Type.

NOTE - As of the writing of this Technical Note, the Terrestrial File Transfer Service has not been defined, but it is assumed to be bidirectional (forward and return).

Figure 4-31 illustrates the internal composition of the Terrestrial File Transfer SC specialization.

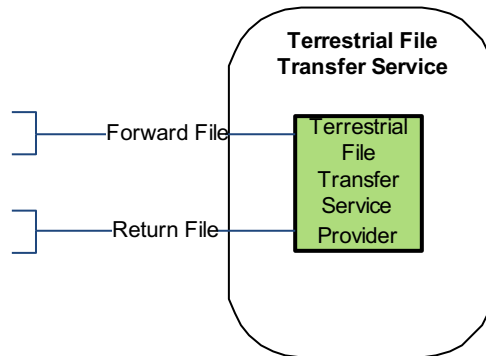

Figure 4-31: Internal Composition of the Terrestrial File Transfer Service Component

4.11.4.1 Terrestrial File Transfer Service Provider

The OID of the Terrestrial File Transfer Service Provider FR Type is {crossSupportFunctionalities terrFileXferSvcProvider (20)}.

The Terrestrial File Transfer Service Provider FR Type corresponds to the functions to be specified in a future Terrestrial File Transfer Service Specification Recommended Standard.

4.11.5 SLE RETURN ALL FRAMES SC SPECIALIZATION OF THE DATA TRANSFER SERVICES ASC

The Return All Frames (RAF) SC specialization of the Data Transfer Service ASC consists of the RAF TS Provider FR Type. Figure 4-32 illustrates the internal composition of the Return All Frames SC specialization.

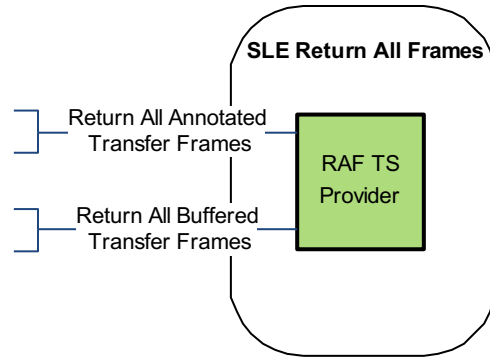

Figure 4-32: Internal Composition of the Return All Frames Service Component

4.11.5.1 RAF TS Provider

The OID of the RAF TS Provider FR Type is

{crossSupportFunctionalities raftTsProvider (33)}.

The RAF TS Provider FR Type corresponds to the functions specified in the SLE Return All Frames Service Specification Recommended Standard.

4.11.6 SLE RETURN CHANNEL FRAMES SC SPECIALIZATION OF THE DATA TRANSFER SERVICES ASC

The Return Channel Frames (RCF) SC specialization of the Data Transfer Services ASC consists of the RCF TS Provider TS Type. Figure 4-33 illustrates the internal composition of the Return Channel Frames SC specialization.

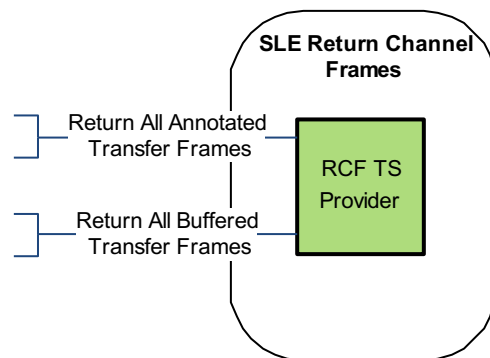

Figure 4-33: Internal Composition of the Return Channel Frames Service Component

4.11.6.1 RCF TS Provider

The OID of the RCF TS Provider FR Type is

{crossSupportFunctionalities rcfTsProvider (34)}.

The RCF TS Provider FR Type corresponds to the functions specified in the SLE Return Channel Frames Service Specification Recommended Standard.

4.11.7 SLE RETURN OPERATIONAL CONTROL FIELDS SC SPECIALIZATION OF THE DATA TRANSFER SERVICES ASC

The Return Operational Control Fields (ROCF) SC specialization of the Data Transfer Services ASC consists of the ROCF Transfer Service Provider FR Type. Figure 4-34 illustrates the internal composition of the Return Operational Control Fields SC specialization.

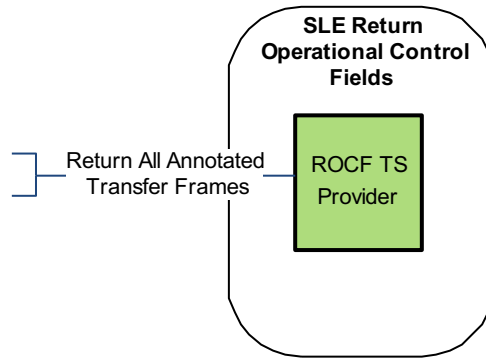

Figure 4-34: Internal Composition of the Return Operational Control Fields Service Component

4.11.7.1 ROCF Transfer Service Provider

The OID of the ROCF TS Provider FR Type is {crossSupportFunctionalities rcfTsProvider (35)}.

The ROCF TS Provider FR Type corresponds to the functions specified in the SLE Return Operational Control Fields Service Specification Recommended Standard (reference [29]).

4.11.8 RETURN UNFRAMED TELEMETRY SC SPECIALIZATION OF THE DATA TRANSFER SERVICES ASC

The Return Unframed Telemetry (RUFT) SC specialization of the Data Transfer Services ASC consists of the RUFT CSTS Provider FR Type. Figure 4-35 illustrates the internal composition of the Return Unframed Telemetry SC specialization.

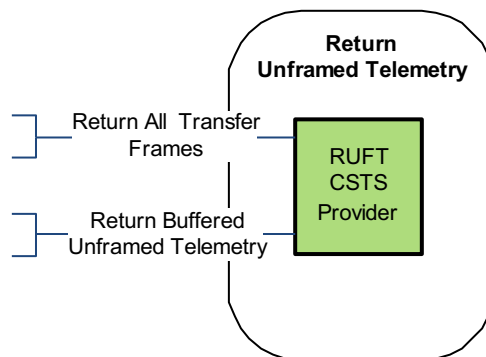

Figure 4-35: Internal Composition of the Return Unframed Telemetry Service Component

4.11.8.1 RUFT CSTS Provider

The OID of the RUFT CSTS Provider FR Type is {crossSupportFunctionalities ruftCstsProvider (36)}.

The RUFT CSTS Provider FR Type corresponds to the functions to be specified in the future RUFT CSTS Recommended Standard.

4.11.9 TRACKING DATA CSTS SC SPECIALIZATION OF THE DATA TRANSFER SERVICES ASC

The Tracking Data CSTS specialization of the Data Transfer Services ASC consists of the Tracking Data CSTS Provider FR Type. Figure 4-36 illustrates the internal composition of the Tracking Data CSTS SC specialization.

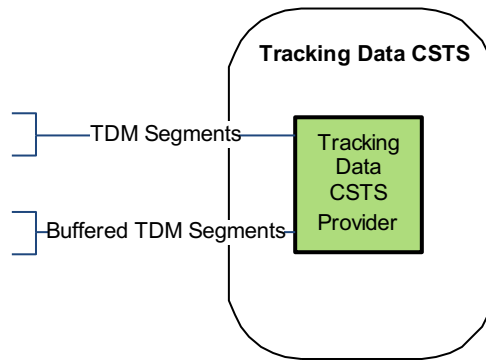

Figure 4-36: Internal Composition of the Tracking Data CSTS Service Component

4.11.9.1 Tracking Data CSTS Provider

The OID of the Tracking Data CSTS Provider FR Type is {crossSupportFunctionalities tdCstsProvider (43)}.

The Tracking Data CSTS Provider FR Type corresponds to the functions specified in the draft Tracking Data CSTS Recommended Standard (reference [8]).

NOTE - The TD-CSTS provides the IOAG Real-Time Data Radiometric service. In addition to delivering radiometric data in “real time” (that is, during the execution of the SLS), the TD-CSTS may also be used to deliver tracking data after the conclusion of the SLS. However, the tracking data measurements will have been sampled at a defined rate.

4.12 SERVICE MANAGEMENT FUNCTIONS ABSTRACT SERVICE COMPONENT

4.12.1 MONITORED DATA SPECIALIZATION OF THE SERVICE MANAGEMENT FUNCTIONS ASC

The FR Types that compose the Monitored Data specialization of the Service Management Functions ASC are:

- a) Monitored Data CSTS Provider;
- b) Monitored Data Collection.

Figure 4-37 illustrates the internal composition of the Monitored Data SC specialization.

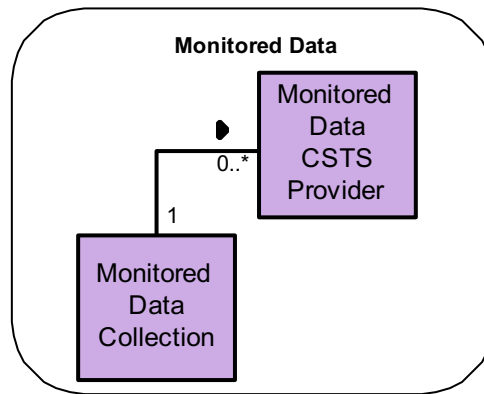

Figure 4-37: Internal Composition of the Monitored Data Service Component

4.12.1.1 Monitored Data CSTS Provider

The OID of the Monitored Data CSTS Provider FR Type is {crossSupportFunctionalities mdCstsProvider (51)}.

The Monitored Data CSTS Provider FR Type corresponds to the functions specified in the draft Monitored CSTS Recommended Standard.

The Monitored Data CSTS Provider FR Type and the Monitored Data CSTS are outside the scope of the Cross Support Reference Model.

4.12.1.2 Monitored Data Collection

The OID of the Monitored Data Collection FR Type is {crossSupportFunctionalities mdCollection (52)}.

Monitored Data Collection constitutes the Data Collection production functions associated with collecting periodically-sampled monitored data values, receiving event notifications, and retrieving the current values of the Functional Resources that are operating during a Space Link Session.

The Monitored Data Collection FR Type corresponds to the Data Collection production function identified in the draft Monitored Data CSTS Recommended Standard.

4.12.2 SERVICE CONTROL SPECIALIZATION OF THE SERVICE MANAGEMENT FUNCTIONS ASC

The FR Types that compose the Service Control specialization of the Service Management Functions ASC are:

- a) Service Control CSTS Provider FR Type;
- b) Service Control Production.

Figure 4-38 illustrates the internal composition of the Service Control SC specialization.

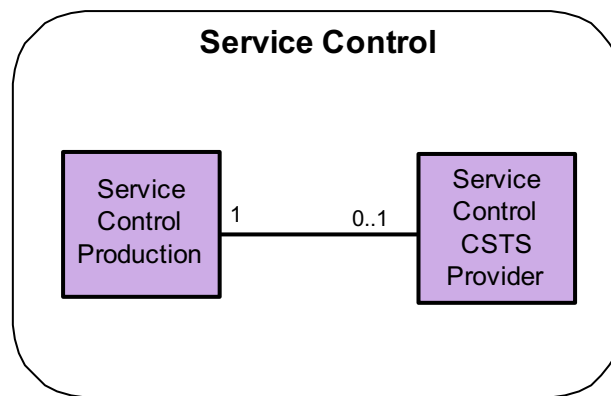

Figure 4-38: Internal Composition of the Service Control Service Component

4.12.2.1 Service Control CSTS Provider

The OID of the Service Control CSTS Provider FR Type is {crossSupportFunctionalities scCstsProvider (53)}.

The Service Control CSTS Provider FR Type corresponds to the functions to be specified in a future Service Control CSTS Specification Recommended Standard.

4.12.2.2 Service Control Production

The OID of the Service Control Production FR Type is {crossSupportFunctionalities scProduction (54)}.

Service Control Production constitutes the production functions associated with the Service Control CSTS.

The Service Control Production FR Type corresponds to the Service Control Production functions to be defined in the future Service Control CSTS Recommended Standard.

The Service Control Production FR Type and the Service Control Production functions are outside the scope of the Cross Support Reference Model.

4.13 SPACE INTERNETWORKING ABSTRACT SERVICE COMPONENT

The Space Internetworking ASC will support IOAG Service Catalog 2 (reference [16]). An early, Agency-specific implementation of Internet Protocol (IP) over CCSDS is represented by the IP over CCSDS specialization of the Space Internetworking ASC.

4.13.1 IP OVER CCSDS SPECIALIZATION OF THE SPACE INTERNETWORKING ABSTRACT SERVICE COMPONENT

The FR Types that compose the IP over CCSDS specialization of the Space Internetworking ASC are:

- a) Forward IP-VC Map; and
- b) Return IP over CCSDS Extractor/Router.

These FR types are not CCSDS-standard types. Rather, they correspond to Agency-specific (in this case, NASA) FR types. Figure 4-39 illustrates the internal composition of the IP over CCSDS SC specialization.

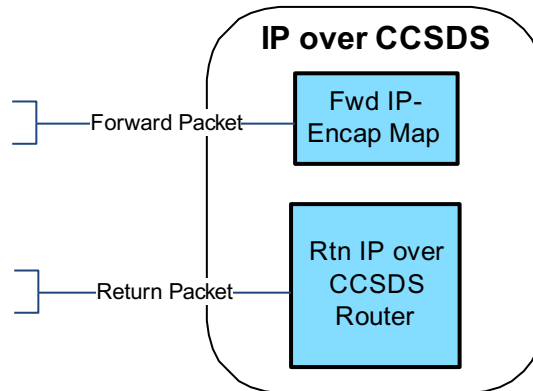

Figure 4-39: Internal Composition of the IP over CCSDS Service Component

Note that two functional resources in the SC are not connected to each other. They are included in the same SC because they are expected to be implemented in tandem.

4.13.1.1 Forward IP-VC Map

The Forward IP-VC Map FR Type will be registered under the NASA subnode of the {crossSupportResources agenciesFunctionalities (2)} subtree of the registration tree.

The Forward IP-VC Map constitutes the functions of identifying which IP addresses are to be routed to which virtual channels.

This FR Type corresponds to the IP Encapsulation over CCSDS service that is provided by the NASA Space Network Ground Segment Sustainment (SGSS) project.

4.13.1.1.1 Return IP over CCSDS Extractor/Router

The Return IP over CCSDS Extractor/Router FR Type will be registered under the NASA subnode of the {crossSupportResources agenciesFunctionalities (2)} subtree of the registration tree.

The Return IP over CCSDS Extractor/Router constitutes the function of identifying which VCs bear IP traffic that needs to be extracted and routed to the Internet.

This FR Type corresponds to the IP Encapsulation over CCSDS service that is provided by the NASA Space Network Ground Segment Sustainment (SGSS) project.

5 SERVICE PROFILES FOR SERVICES IN SLS CONFIGURATIONS

Table 5-1 summarizes the ASCs that are used by each of the services in the SLS configuration, and the conditions (if any) for that usage. “M” designates that the ASC is mandatory in all cases. “Cx” identifies the condition under which the ASC is used. Absence of any entry designates that the ASC plays no role in the production or provision of the service under any circumstances.

The following subsections map each of the SLS configuration services to the SCs that participate in the production and/or provision of that service in the SLS configuration. For each service, the following information each ASC that is associated with that service is identified, whether the ASC is mandatory or optional for that service, if optional, the conditions under which the ASC is included.

Table 5-1: Abstract Service Components Used in the SLS Configuration Services

ASC -> ----- SLS service v	Aperture	Forward Physical Channel Xmission	Forward Sync & Channel Encoding	Forward Space Link Protocol Xmission	Return Physical Channel Reception	Return Sync & Channel Decoding	Return Space Link Protocol Reception	SLS Data Delivery Production	SLS Radiometric Data Production	Offline Data Storage	Data Transfer Services
Forward CLTU	M	M	M	M	C 1	C 1	C 1				M
Forward Space Packet	M	M	M	M	C2	C2	C2				M
Forward Frame	M	M	M	C3	C5	C5	C5				M
SLS Fwd File Transmission	M	M	M	M	C4	C4	C4	M		M	
Fwd File Offline Delivery										M	M
SLS RAF	M				M	M					M
Return Frame Storage	M				M	M		M		M	
SLS RCF	M				M	M					M
ROCF	M				M	M					M
SLS RUFT	M				M	M					M
TM Segment Storage	M					M		M		M	
SLS Return File Storage	M	C4	C4	C4	M	M	M	M		M	
Pre-Validated RM Data Storage	C6	C7			M				M	M	
SLS Raw Data Radiometric	C6	C7			M				M		M
TDM Segment Storage	C6	C7			M				M	M	
Delta-DOR	M				M				M	M	
Open Loop	M				M				M	M	

DRAFT TECHNICAL NOTE CONCERNING THE FUNCTIONAL RESOURCE REFERENCE
MODEL

Conditions										
C1	Required if forward link status is required to control production status					C4	Required if the service is operating in Reliable Transfer mode			
C2	Required if forward link status is required to control production status or if the services is running over COP					C5	Required if the service is operating in TC Frame mode and forward link status is required to control production status			
C3	Required if service is transferring TC Frames or AOS frames					C6	Required if the service delivers Pointing Angles data			
C4	Required if the service is operating in Reliable Transfer					C7	Required if the service delivers Transmit Frequency or Doppler			
C5	Required if the service is operating in TC Frame mode and forward link status is required to control production status									

For each ASC used by a service, the following are identified:

- a. Whether the service will be able to use other future SC specializations of ASC or is limited to the existing specialization(s);
- b. The existing SC(s) that are to be used for the service. An existing specialization is one that is based on one or more published CCSDS Recommended Standards (or other standards) that are expected to be used for the service. Any constraints with respect to specific specializations are noted. If multiple specializations are identified, only one specialization can be used in any given Configuration Profile;
- c. For each specialization, the Accessor port(s), if any, used in the configuration of that service, and whether the port is an essential port (see below) of the parent ASC or defined for the SC; and
- d. For each SC specialization, the Service Access Point (SAP) port(s), if any, used in the configuration of that service, and whether the port is an essential port of the parent ASC or defined for the SC.

The SAP/Accessor ports are used to identify the relationships between instances of different SC types. These port pairs are necessary to eliminate the ambiguity when multiple instances of the same SC exist within a Service Package, or when a type of SC has different types of relationships with other types of SCs. Each port pair is named for the principal data type that is exchanged between the SC types, but the relationship is not necessarily limited to that data exchange.

The SC that possesses the SAP port is the SC that provides its “service” to other SCs¹. An SC with an Accessor port of a particular type is one that requires that service from an SC. The SAP port normally belongs to the SC “nearer to” the space link, and the Accessor port normally belongs to the SC of the pair that is “farther away.”

AUTHOR’S NOTE - In the following tables, the FRs of each SC that are actually used by the service will be added

¹ The term “service” in the context of SAP and Accessor ports is not to be confused with the use of the term in the larger Space Communication Cross Support sense. In the SAP/Accessor port context it is roughly equivalent to the notion of service between layers of the ISO OSI protocol stack. This is the inspiration for using *SAP* to designate the port at which the service is provided.

Some of the services have *modes* and/or *options* that determine which ASCs, SCs, and/or ports are involved in a particular configuration of the service. The modes of a service represent different variants of the service. The values of a *mode* are mutually exclusive at any given time. For example, the Forward Frame service has three Service Data Unit modes: Telecommand (TC) Frame mode, Advanced Orbiting System (AOS) AOS Frame mode, and AOS Channel Access Data Unit (CADU) mode. An instance of the Forward Frame service can be configured in only one of these modes at any given time. Services can even have multiple mode types, where any one configuration must have values specified for each of the mode types. As an abstract example, a service might have one of its mode types being the type of Service Data Unit carried, and another being the kind of space link protocol to use.

Options are additional capabilities that can be configured as part of the provision or production of the service. Options can exist for the service as a whole or they can be tied to specific modes of the service.

Each of the service descriptions includes the following:

- a. The name of each of the ASCs that are used to configure that service in an SLS configuration. If the ASC is optional or dependent on the mode of the service, those dependencies are also identified;
- b. A class diagram of the known or planned SC that will be used to configure that service;
- c. If the service has modes, a table that identifies the modes of the service. If the service has only one mode type, the syntax “M n ” is used, where n is an integer value that represents one possible mode value for that mode. If the service has multiple mode types, each mode type is designated using the syntax “MX n ”, where X is an alphabetic character identifying the mode type and where n is an integer value that represents one possible mode value for that mode type. The Mode table lists the mode identifiers, the mode names (qualified by mode type if multiple mode type if multiple mode types are available in the service), and a brief description of the mode value;
- d. If the service has options, a table that identifies the options for the service. The syntax “O n ” is used, where n is an integer value that represents the individual option. The Option table lists the option identifiers, the option names, and a brief description of the option. If the option is predicated on specific modes, that conditional dependency is identified as a predicate of the option; and
- e. A table that specifies:
 1. The name of each ASC that is used to configure that service in an SLS configuration. If the use of that ASC for that service is dependent on particular modes or options, the name is prefixed by those modes or options using the following syntax: a logical OR selection among mode or options is represented by commas between the identifiers of those modes or options, and a logical AND is represented by “&” between the identifiers. Thus “M1, M2” means that the ASC is used if either mode 1 or mode 2 is configured, and “M3 & O2” means that the ASC is used only if both mode 3 and option 2 are configured.. Any mode

or option designation also applies to all SC specializations, Accessor ports, and SAP ports of that ASC.

2. Whether new SC specializations can be substituted for the known SCs (Yes) or not (No) in the future.
3. Identification of the SC specializations of the ASC that are known or planned. There may be multiple known or planned SCs, the use of which is dependent on the mode and/or options of the service. If so, the identification of each SC is prefixed with the mode and/or option identifiers using the syntax described above;

NOTE - If multiple SCs are known or planned, the selection of the SC is tied to a mode type.

4. Identification of the Service Access Ports that are used by the ASC in the SLS configuration of the service. If the use of the SAP port is conditional on one or more modes or options in addition to any conditions on use of that entire ASC, that conditional dependency prefixes the name of the SAP port using the syntax described above; and
5. Identification of the Accessor Ports that are used by the ASC. If the use of the Accessor port is conditional on one or more modes or options in addition to any conditions on use of that entire ASC, that conditional dependency prefixes the name of the SAP port using the syntax described above.
6. If notes are needed for clarification, they are designated by integers enclosed in parentheses that index the notes, which immediately follow the table.

5.1 FORWARD DATA DELIVERY SERVICES

5.1.1 FORWARD CLTU SERVICE

The Forward CLTU service is equivalent to the IOAG Service Catalog #1 Forward CLTU Forward Data Delivery service.

The Forward CLTU service is configured using the following ASCs:

- a. Aperture;
- b. Forward Physical Channel Transmission,
- c. Forward Sync and Channel Encoding;
- d. Data Transfer Services;
- e. Return Physical Channel Reception (optional);
- f. Return Sync and Channel Decoding (optional); and
- g. Return Space Link Protocol Reception (optional).

Figure 3-3 illustrates the ASCs and SCs used in the SLS the Forward CLTU service.

DRAFT TECHNICAL NOTE CONCERNING THE FUNCTIONAL RESOURCE REFERENCE MODEL

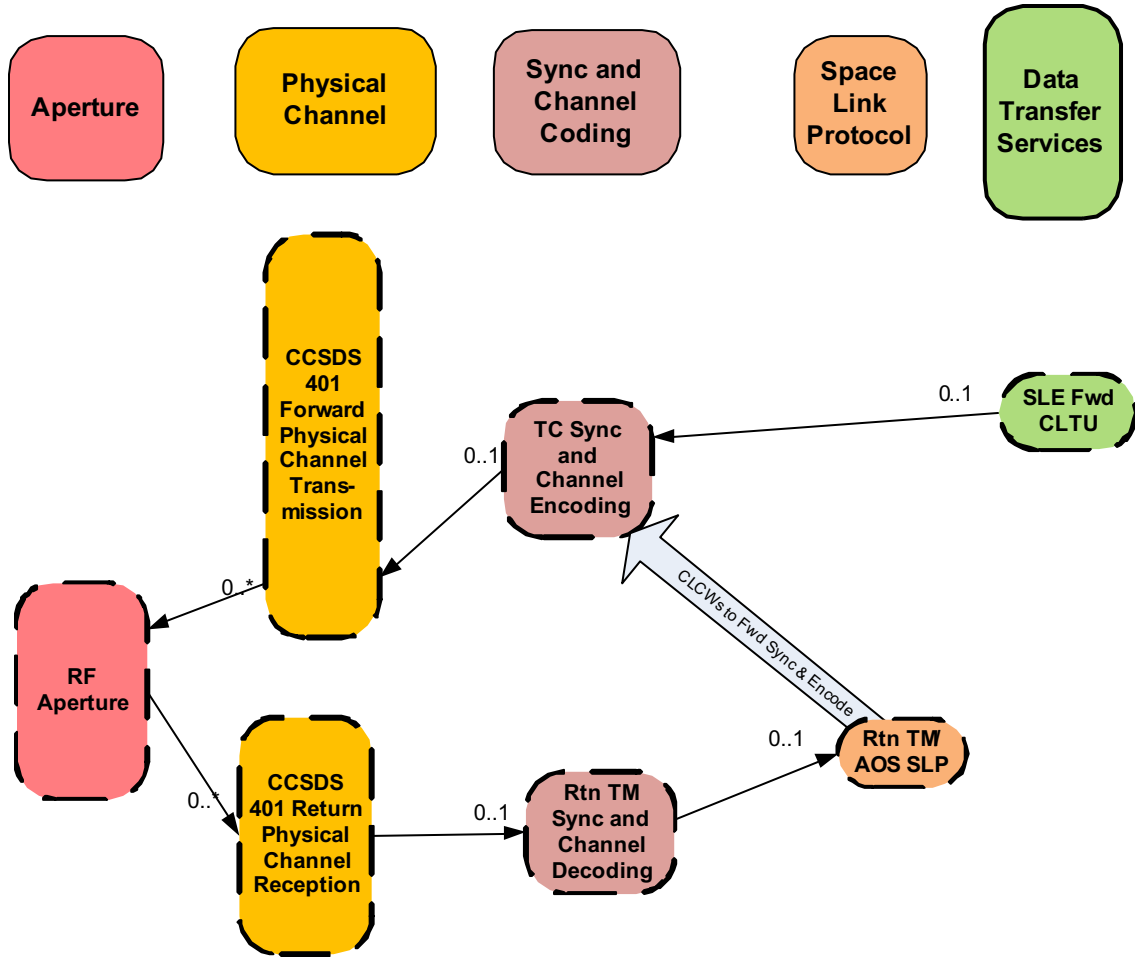

Figure 5-1: SCs Used in Forward CLTU Service

The Forward CLTU service does not support different operating modes.

Table 5-2: Service Options for Forward CLTU Service

Option	Name	Description	Predicate
O1	With Forward Link Status	Transfer of CLTUs is gated based on forward link status information that is reported in the CLCWs of transfer frames received on the return link.	
O1A	With Forward Link Status in MC CLCWs	Transfer of CLTUs is gated based on forward link status information that is reported in the CLCWs of transfer frames received on a master channel of the return link.	
O1B	With Forward Link Status in VC CLCWs	Transfer of CLTUs is gated based on forward link status information that is reported in the CLCWs of transfer frames received on a virtual channel of the return link.	

Table 5-3: ASC Characteristics in Forward CLTU Service

ASC	Future Replaceable	Known Specialization	SAP Port Used	Accessor Port Used
Aperture	Yes	RF Aperture	Forward Modulated Waveform (essential) O1: Return Modulated Waveform (essential).	none
Forward Physical Channel Transmission	Yes	CCSDS 401 Forward Physical Channel Transmission	Forward Physical Channel Symbols (essential).	Forward Modulated Waveform (essential) O1: CLCW (specialization).
Forward Sync and Channel Encoding	Yes (1)	TC Sync and Channel Encoding	CLTU (specialization)	Forward Physical Channel Symbols (essential)
Data Transfer Services	No	Forward CLTU	n/a	CLTU (specialization).
O1: Return Physical Channel Reception	Yes	CCSDS 401 Return Physical Channel Reception.	Return Physical Channel Symbols (essential).	Return Modulated Waveform (essential).
O1: Return Sync and Channel Decoding	Yes	Return TM Synchronization and Channel Decoding	Return All Transfer Frames (essential).	Return Physical Channel Symbols (essential).
O1: Return Space Link Protocol Reception	Yes (2)	Return TM/AOS Space Link Protocol Reception	CLCW (specialization)	Return All Transfer Frames (essential).

NOTES -

- 1 Due to the TC-specific nature of the Forward CLTU service, it is nominally tied to the TC Sync and Channel Encoding specialization. However, the SLE Forward CLTU service specification has an escape clause that allows it to be used to transfer any block of octets, so theoretically it could be used for a non TC CLTU forward service (such as a pseudo-serial command stream service).

- 1 Any future SC specialization of the Return Space Link Protocol Reception ASC must provide a CLCW SAP if it is to be used to support Forward CLTU service that is gated by forward link status information.

5.1.2 FORWARD SPACE PACKET SERVICE

The Forward Space Packet service is equivalent to the IOAG Service Catalog #1 Forward Space Packet Forward Data Delivery service.

The Forward Space Packet service is configured using the following ASCs:

- a. Aperture;
- b. Forward Physical Channel Transmission,
- c. Forward Sync and Channel Encoding;
- d. Forward Space Link Protocol;
- e. Data Transfer Services;
- f. Return Physical Channel Reception (optional);
- g. Return Sync and Channel Decoding (optional);
- h. Return Sync and Channel Decoding (optional); and
- i. Return Space Link Protocol Reception (optional).

Figure 5-2 illustrates the ASCs and SCs used in the Forward Space Packet service.

DRAFT TECHNICAL NOTE CONCERNING THE FUNCTIONAL RESOURCE REFERENCE MODEL

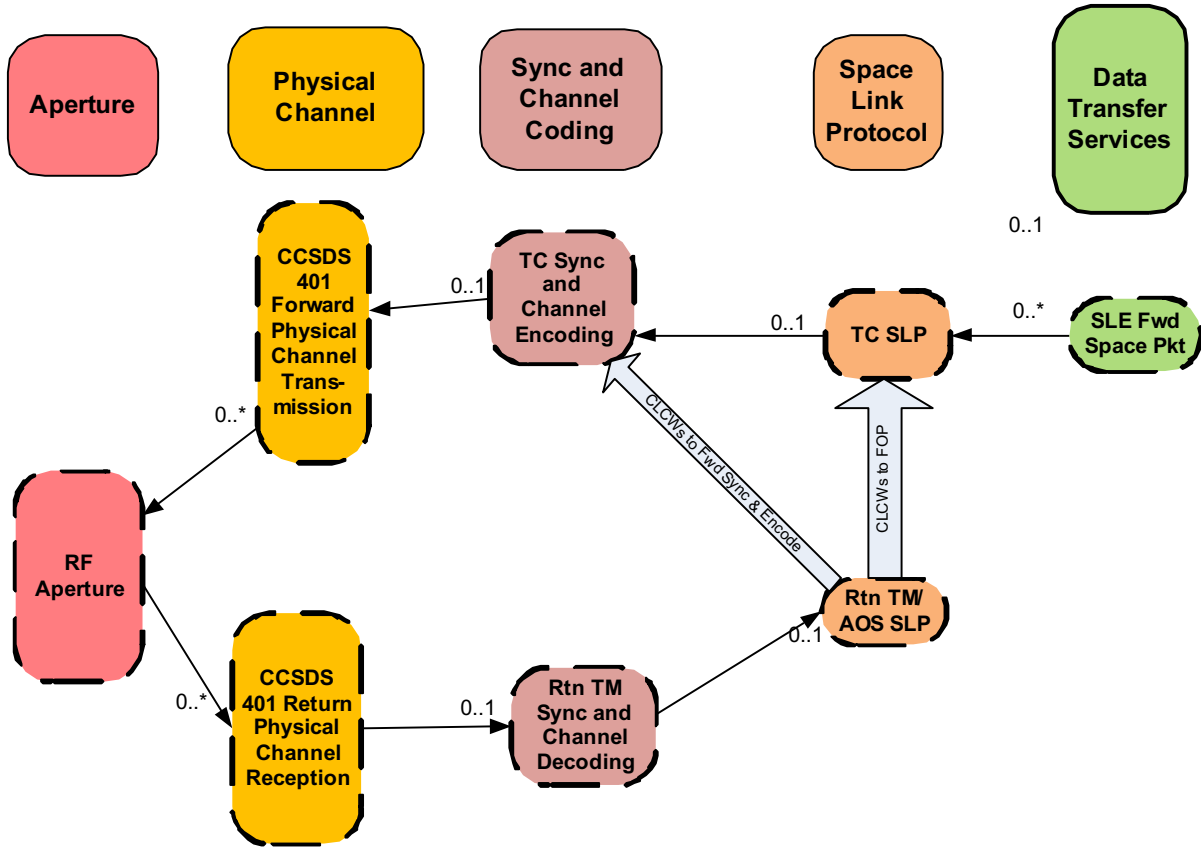

Figure 5-2: SCs Used in Forward Space Packet Service

The Forward Space Packet service does not support different service modes. The service options are listed in Table 5-4.

Table 5-4: Service Options for Forward Space Packet Service

Option	Name	Description	Predicate
O1	With Forward Link Status	Transfer of CLTUs is gated based on forward link status information that is reported in the CLCWs of transfer frames received on the return link.	
O1A	With Forward Link Status in MC CLCWs	Transfer of CLTUs is gated based on forward link status information that is reported in the CLCWs of transfer frames received on a master channel of the return link.	
O1B	With Forward Link Status in VC CLCWs	Transfer of CLTUs is gated based on forward link status information that is reported in the CLCWs of transfer frames received on a virtual channel of the return link.	

DRAFT TECHNICAL NOTE CONCERNING THE FUNCTIONAL RESOURCE REFERENCE
MODEL

O2	COP-1	COP-1 is used for reliable transmission of the Space Packets.	

Table 5-5: ASC Characteristics in Forward Space Packet Service

ASC	Future Replaceable	Known Specialization	SAP Port Used	Accessor Port Used
Aperture	Yes	RF Aperture	Forward Modulated Waveform (essential) O1, O2: Return Modulated Waveform (essential).	none
Forward Physical Channel Transmission	Yes	CCSDS 401 Forward Physical Channel Transmission.	Forward Physical Channel Symbols (essential).	Forward Modulated Waveform (essential) O1: CLCW (specialization).
Forward Sync and Channel Encoding	Yes (1)	TC Sync and Channel Encoding	Forward All Transfer Frames (essential)	Forward Physical Channel Symbols (essential)
Forward Space Link Protocol Transmission	Yes	TC Space Link Protocol Transmission (1)	Forward Packet (essential)	Forward All Transfer Frames (essential) O2: CLCW (specialization).
Data Transfer Services	No	Forward Space Packet	n/a	Forward Packet (specialization).
O1, O2: Return Physical Channel Reception	Yes	CCSDS 401 Return Physical Channel Reception.	Return Physical Channel Symbols (essential).	Return Modulated Waveform (essential).

DRAFT TECHNICAL NOTE CONCERNING THE FUNCTIONAL RESOURCE REFERENCE
MODEL

O1, O2: Return Sync and Channel Decoding	Yes	Return TM Synchronization and Channel Decoding	Return All Transfer Frames (essential).	Return Physical Channel Symbols (essential).
O1, O2: Return Space Link Protocol Reception	Yes (2)	Return TM/AOS Space Link Protocol Reception	CLCW (specialization)	Return All Transfer Frames (essential).

NOTES

- 1 -As currently defined, the SLE Forward Space Packet service operates only over TC space link protocols and TC sync and channel coding. However, the Cross Support Reference Model (reference [1]) also allows Forward Space Packet service to operate over AOS forward links, and other sync and coding schemes may arise in the future.
- 1 Any future SC specialization of the Return Space Link Protocol Reception ASC must provide a CLCW SAP if it is to be used to support Forward Space Packet service that operates over COP-1 and/or is gated by forward link status information.

5.1.3 FORWARD FRAMES SERVICE

The Forward Frames service is equivalent to the OIAG Service Catalog #2 Forward Frames Forward Data Delivery service, and as such includes the functionality of the IOAG Service Catalog #1 Forward Synchronous Encoded Frames Forward Data Delivery service.

NOTE - IOAG SC #1 calls for a Forward Synchronous Encoded Frame (FSEF) service. However, the FSEF service is a subset of the Forward Frames (FF) service which is included in IOAG SC #2. As a practical consideration CCSDS is currently planning to develop only the FF service.

The Forward Frames service is configured using the following ASCs:

- a. Aperture;
- b. Forward Physical Channel Transmission,
- c. Forward Sync and Channel Encoding;
- d. Forward Space Link Protocol;
- e. Data Transfer Services;
- f. Return Physical Channel Reception (optional);
- g. Return Sync and Channel Decoding (optional); and
- h. Return Space Link Protocol Reception (optional).

Figure 5-3 illustrates the ASCs and SCs used in the Forward Frames service.

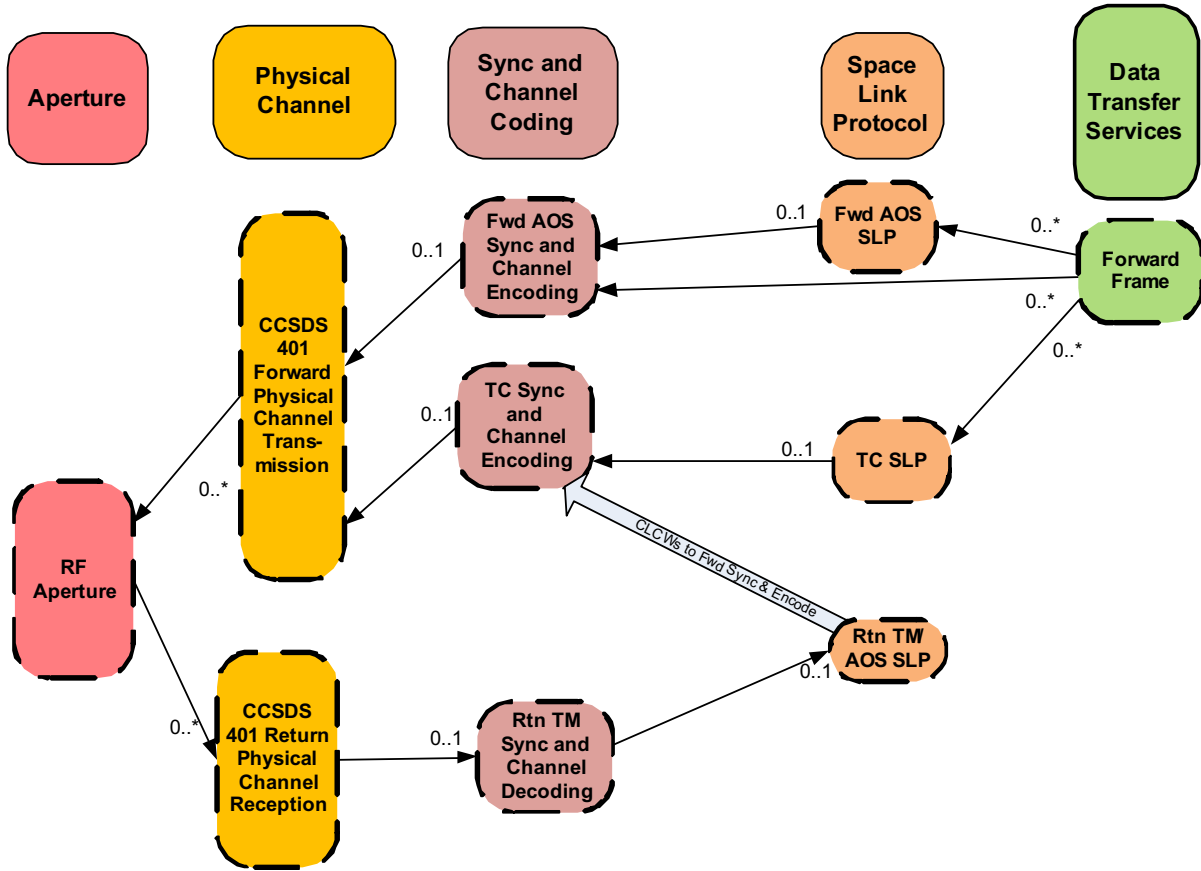

Figure 5-3: SCs Used in Forward Frame Service

Table 5-6: Service Modes for Forward Frame Service

Mode	Name	Description
M1	TC Frame Mode	Transfer of frames in TC Frame mode
M2	AOS Frame Mode	Transfer of frames in AOS Frame mode
M3	AOS CADU Mode	Transfer of frames embedded in CADUs in AOS CADU mode

Table 5-7: Service Options for Forward Frame Service

Option	Name	Description	Predicate
O1	With Forward Link Status	Transfer of frames in TC Frame mode, where transmission of the CLTUs containing those TC frames is gated based on forward link status information that is reported in the CLCWs of transfer frames received on	M1

	the return link.	
--	------------------	--

Table 5-8: ASC Characteristics in Forward Frame Service

ASC	Future Replace-able	Known Specialization	SAP Port Used	Accessor Port Used
Aperture	Yes	RF Aperture	Forward Modulated Waveform (essential) O1: Return Modulated Waveform (essential).	n/a
Forward Physical Channel Transmission	Yes	CCSDS 401 Forward Physical Channel Transmission	Forward Physical Channel Symbols (essential).	Forward Modulated Waveform (essential).
Forward Sync and Channel Encoding	Yes	M1: TC Sync and Channel Encoding M2, M3: AOS Sync and Channel Encoding	M1, M2: Forward All Transfer Frames (essential) M3 - Forward AOS CADU (specialization)	Forward Physical Channel Symbols (essential). O1: CLCW (specialization).
M1, M2: Forward Space Link Protocol Transmission	Yes	M1: TC Space Link Protocol Transmission M2: Forward AOS Space Link Protocol Transmission	M1: TC VC Frames (specialization) M2: Forward AOS VC Frames (specialization)	Forward All Transfer Frames (essential).

DRAFT TECHNICAL NOTE CONCERNING THE FUNCTIONAL RESOURCE REFERENCE
MODEL

ASC	Future Replace-able	Known Specialization	SAP Port Used	Accessor Port Used
Data Transfer Services	No	Forward Frame	n/a	M1: TC VC Frames (specialization). M2: Forward AOS VC Frames (specialization). M3: Forward AOS CADU (specialization).
O1: Return Physical Channel Reception	Yes	CCSDS 401 Return Physical Channel Reception.	Return Physical Channel Symbols (essential port).	Return Modulated Waveform (essential).
O1: Return Sync and Channel Decoding	Yes	Return TM Synchronization and Channel Decoding	Return All Transfer Frames (essential).	Return Physical Channel Symbols (essential).
O1: Return Space Link Protocol Reception	Yes	Return TM/AOS Space Link Protocol Reception.	CLCW (specialization)	Return All Transfer Frames (essential).

5.1.4 SLS FORWARD FILE TRANSMISSION SERVICE

The IOAG definition of the Forward File service spans two of the service configurations: SLS and forward offline. Because the Forward File service will have to be treated separately by Service Management for each of these configurations, the IOAG Forward File service is treated as two different services: SLS Forward File Transmission service (covering the functions that are performed when the space link is active) and Forward File Offline Delivery service (covering the functions performed to get the file to the ESLT, perhaps before the time that the space link is available).

IOAG SC#1 defines² the Forward File service as follows:

This Service enables a mission to send the contents of a file to a spacecraft by allowing a Control Center to provide a Ground Tracking Asset with files for uplink. Within Catalog #1, usage of this service is limited to a spacecraft directly reachable from a Ground Tracking Asset (i.e. single hop

² This definition has been modified to include material that was merely referenced in the original IOAG SC#1 definition.

DRAFT TECHNICAL NOTE CONCERNING THE FUNCTIONAL RESOURCE REFERENCE
MODEL

space link). It relies on the following Space Link Interface Standards and Ground Link Interface Standards.

- CSTS Forward File Service [CFFS] over CSTS Transfer File Service [CFXS]
- Space Packet Protocol [SPP]
- Encapsulation Service [ENC]
- CCSDS File Delivery Protocol [CFDP]
- AOS Space Data Link Protocol [AOS]
- TC Space Data Link Protocol [TC-DLP]³
- TM Synchronization and Channel Coding [TM-S&C]
- TC Synchronization and Channel Coding [TC-S&C]
- Radio Frequency and Modulation [RFM] limited to modules for “Earth-to-Space Radio Frequency (Forward Link)” and “Telecommand (Forward Link)”

Remark - The two CSTS File Services listed above are “to be written”. It is assumed that a generic transfer file service allowing to transfer files between two units, i.e. [CFXS], will be available and - on top of this generic service – more “specialized” file services will allow requesting the dedicated processing for the file being transferred. Therefore, it is expected that the CSTS Forward File Service will allow the Control Center to inform whether the file contains

- a collection of Space Packets,
- a collection of Encapsulation Packets, or
- a file to be processed into CFDP PDUS to be embedded either in Space Packets or Encapsulation Packets.

Additionally the CSTS Forward File Service will allow the Control Center to state how the Space/Encapsulation Packets shall be forwarded to the spacecraft either within TC Frames or AOS Frames.

This section addresses the SLS Forward File Transmission service. The Forward File Offline Delivery service is covered in 7.1.1.

The SLS Forward File Transmission service is configured using the following ASCs:

- a. Aperture;
- b. Forward Physical Channel Transmission,
- c. Forward Sync and Channel Encoding;
- d. Forward Space Link Protocol;
- e. SLS Data Delivery Production;
- f. Offline Data Storage;
- g. Return Physical Channel Reception (optional);
- h. Return Sync and Channel Decoding (optional);
- i. Return Sync and Channel Decoding (optional); and
- j. Return Space Link Protocol Reception (optional).

³ The IOAG SC#1 definition of the Forward File service does not contain the TC Space Data Link Protocol in its list of component Space Link Interface Standards. However, the inclusion of the TC Synchronization and Channel Coding standard and the mention of “TC Frames” in the final paragraph of the quote implies that the Forward Frames service was intended to run over the TC stack as well as the Forward AOS stack.

Figure 5-4 illustrates the ASCs and SCs used in the SLS Forward File Transmission service.

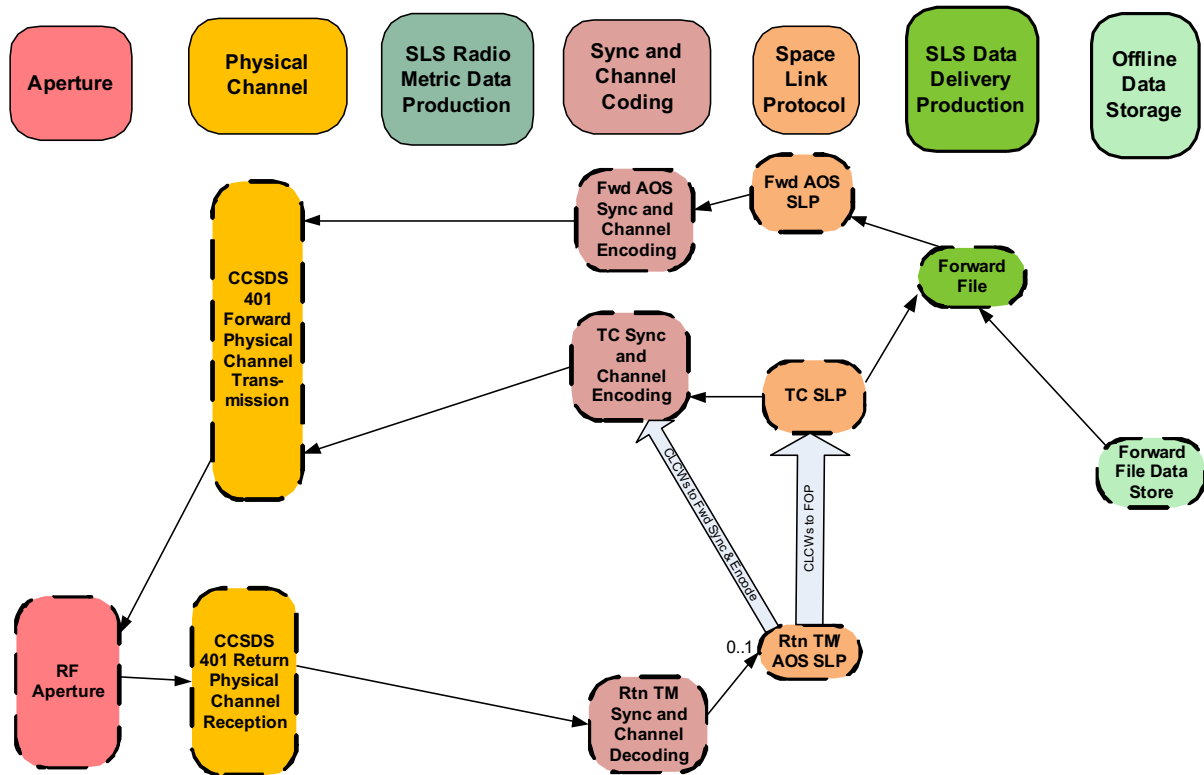

Figure 5-4: SCs Used in SLS Forward File Transmission Service

Table 5-9: Service Modes for SLS Forward File Transmission Service

Mode	Name	Description
MA1	Space Link Protocol: TC Mode	Use of TC Space Link Protocol for forward transfer
MA2	Space Link Protocol: AOS Mode	Use of AOS Forward Space Link Protocol for forward transfer

Table 5-10: Service Options for SLS Forward File Transmission Service

Option	Name	Description	Predicate
O1	Reliable CFDP	Files are transmitted via CFDP operating in reliable mode	
O2	With Forward Link Status	Transfer of CLTUs is gated based on forward link status information that is reported in the CLCWs of transfer frames received on the return link.	MA1

DRAFT TECHNICAL NOTE CONCERNING THE FUNCTIONAL RESOURCE REFERENCE
MODEL

O3	COP-1	COP-1 is used for reliable transmission of the Space Packets.	MA1
----	-------	---	-----

NOTE - If the file transfer is performed using reliable CFDP (option O1), COP-1 (option O3) will not be used.

Table 5-11: ASC Characteristics in SLS Forward File Transmission Service

ASC	Future Replace-able	Known Specialization	SAP Port Used	Accessor Port Used
Aperture	Yes	RF Aperture	Forward Modulated Waveform (essential) O1, O2, O3: Return Modulated Waveform (essential).	n/a
Forward Physical Channel Transmission	Yes	CCSDS 401 Forward Physical Channel Transmission	Forward Physical Channel Symbols (essential).	Forward Modulated Waveform (essential).
Forward Sync and Channel Encoding	Yes	MA1: TC Sync and Channel Encoding MA2: AOS Sync and Channel Encoding	Forward All Transfer Frames (essential)	Forward Physical Channel Symbols (essential) O2: CLCW (specialization).
Forward Space Link Protocol Transmission	Yes	MA1: TC Space Link Protocol Transmission MA2: Forward AOS Space Link Protocol Transmission	Forward Packet (essential)	Forward All Transfer Frames (essential). O3: CLCW (specialization).

DRAFT TECHNICAL NOTE CONCERNING THE FUNCTIONAL RESOURCE REFERENCE
MODEL

ASC	Future Replaceable	Known Specialization	SAP Port Used	Accessor Port Used
SLS Data Delivery Production	No	Forward File Data Delivery Production	Forward Space Data File (specialization)	Forward Packet (essential) O1: Ack CFDP-PDU (specialization).
Offline Data Storage	No	Forward File Data Store	n/a	Forward Space Data File (specialization)
O1, O2, O3: Return Physical Channel Reception	Yes	CCSDS 401 Return Physical Channel Reception.	Return Physical Channel Symbols (essential port).	Return Modulated Waveform (essential).
O1, O2, O3: Return Sync and Channel Decoding	Yes	Return TM Synchronization and Channel Decoding	Return All Transfer Frames (essential).	Return Physical Channel Symbols (essential).
O1, O2, O3: Return Space Link Protocol Reception	Yes	Return TM/AOS Space Link Protocol Reception.	Return Packet (essential). O2, O3: CLCW (specialization)	Return All Transfer Frames (essential).

5.2 RETURN DATA DELIVERY SERVICES

5.2.1 SLS RETURN ALL FRAMES SERVICE

The IOAG definition of the Return All Frames Return Data Delivery service spans two of the service configurations: SLS and retrieval. Because the RAF service will have to be treated separately by Service Management for each of these configurations, the service is treated as three different services: SLS RAF service (covering the functions that are performed when the RAF service is operating in ‘online’ mode), Return Frame Capture service (covering the

functions that are performed to capture transfer frames for subsequent transfer), and RAF Retrieval service (covering the functions performed to transfer the frames out of the ESLT in ‘offline’ mode).

This section addresses the SLS RAF service. The Return Frame Capture service is described in 5.2.2. The RAF Retrieval service is described in 6.1.1.

The SLS Return All Frames service is configured using the following ASCs:

- a. Aperture;
- b. Return Physical Channel Reception;
- c. Return Sync and Channel Decoding; and
- d. Data Transfer Services.

Figure 5-5 illustrates the ASCs and SCs used in the SLS Return All Frames service.

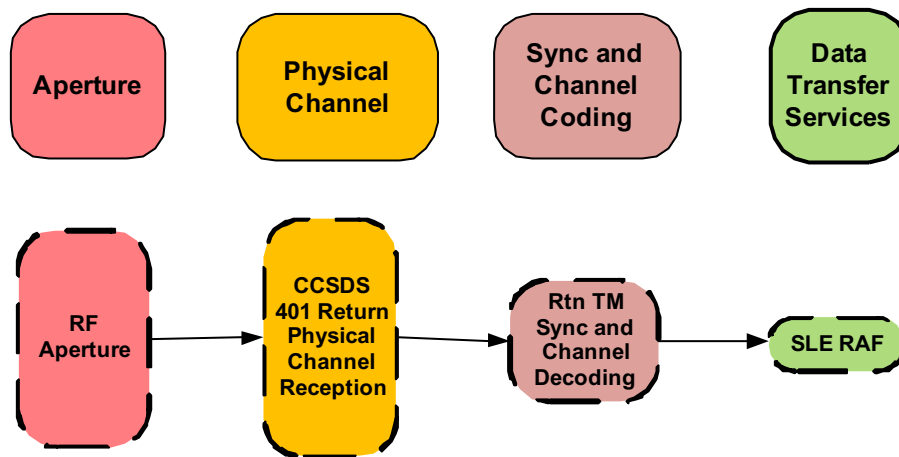

Figure 5-5: SCs Used in SLS Return All Frames Service

Table 5-12: ASC Characteristics in SLS Return All Frames Service

ASC	Future Replaceable	Known Specialization	SAP Port Used	Accessor Port Used
Aperture	Yes	RF Aperture	Return Modulated Waveform (essential)	n/a
Return Physical Channel Reception	Yes	CCSDS 401 Return Physical Channel Reception.	Return Physical Channel Symbols (essential).	Return Modulated Waveform (essential).

ASC	Future Replaceable	Known Specialization	SAP Port Used	Accessor Port Used
Return Sync and Channel Decoding	Yes	Return TM Synchronization and Channel Decoding	Return All Annotated Transfer Frames (specialization)	Return Physical Channel Symbols (essential).
Data Transfer Services	No	SLE Return All Frames	n/a	Return All Annotated Transfer Frames (specialization).

5.2.2 RETURN FRAME CAPTURE SERVICE

The Return Frame Capture service is configured using the following ASCs:

- a. Aperture;
- b. Return Physical Channel Reception;
- c. Return Sync and Channel Decoding;
- d. SLS Data Delivery Production;
- e. Offline Data Storage

Figure 5-5 illustrates the ASCs and SCs used in the Return Frame Capture service.

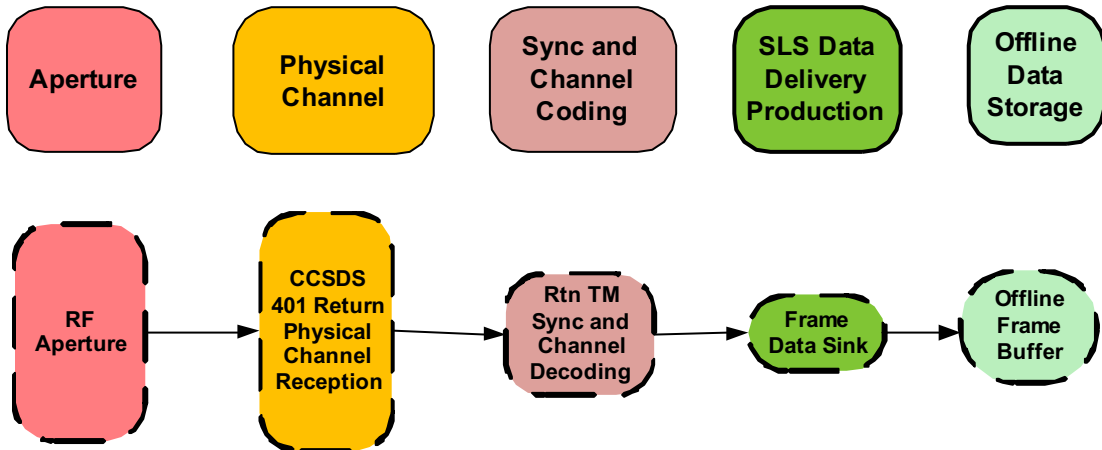

Figure 5-6: SCs Used in Return Frame Capture Service

Table 5-13: ASC Characteristics in Return Frame Capture Service

ASC	Future Replaceable	Known Specialization	SAP Port Used	Accessor Port Used
Aperture	Yes	RF Aperture	Return Modulated Waveform (essential)	n/a

DRAFT TECHNICAL NOTE CONCERNING THE FUNCTIONAL RESOURCE REFERENCE
MODEL

ASC	Future Replaceable	Known Specialization	SAP Port Used	Accessor Port Used
Return Physical Channel Reception	Yes	CCSDS 401 Return Physical Channel Reception.	Return Physical Channel Symbols (essential).	Return Modulated Waveform (essential).
Return Sync and Channel Decoding	Yes	Return TM Synchronization and Channel Decoding	Return All Annotated Transfer Frames (specialization)	Return Physical Channel Symbols (essential).
SLS Data Delivery Production	No	Transfer Frame Data Sink	Return Selected Transfer Frames (specialization)	Return All Annotated Transfer Frames (specialization).
Offline Data Storage	No	Offline Frame Buffer	n/a	Return Selected Transfer Frames (specialization)

5.2.3 SLS RETURN CHANNEL FRAMES SERVICE

The IOAG definition of the Return Channel Frames Return Data Delivery service spans two of the service configurations: SLS and retrieval. Because the RCF service will have to be treated separately by Service Management for each of these configurations, the service is treated as three different services: SLS RCF service (covering the functions that are performed when the RCF service is operating in ‘online’ mode), Return Frame Capture service (which has already been addressed in 5.2.2), and RCF Retrieval service (covering the functions performed to transfer the frames out of the ESLT in ‘offline’ mode).

This section addresses the SLS RCF service. The RCF Retrieval service is described in 6.1.2.

The SLS Return Channel Frames service is configured using the following ASCs:

- a. Aperture;
- b. Return Physical Channel Reception;
- c. Return Sync and Channel Decoding; and
- d. Data Transfer Services.

Figure 5-7 illustrates the ASCs and SCs used in the SLS Return Channel Frames service.

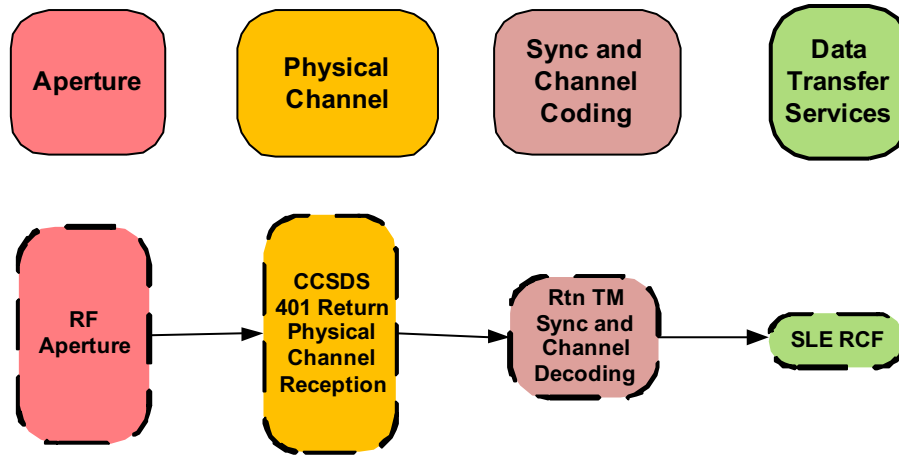

Figure 5-7: SCs Used in SLS Return Channel Frames Service

Table 5-14: ASC Characteristics in SLS Return Channel Frames Service

ASC	Future Replaceable	Known Specialization	SAP Port Used	Accessor Port Used
Aperture	Yes	RF Aperture	Return Modulated Waveform (essential)	n/a
Return Physical Channel Reception	Yes	CCSDS 401 Return Physical Channel Reception.	Return Physical Channel Symbols (essential).	Return Modulated Waveform (essential).
Return Sync and Channel Decoding	Yes	Return TM Synchronization and Channel Decoding	Return All Annotated Transfer Frames (specialization)	Return Physical Channel Symbols (essential).
Data Transfer Services	No	SLE Return Channel Frames	n/a	Return All Annotated Transfer Frames (specialization).

5.2.4 RETURN OPERATIONAL CONTROL FIELDS SERVICE

The ROCF service is equivalent to the IOAG Service Catalog #1 ROCF Return Data Delivery service.

The ROCF service operates in the SLS configuration only, and is configured using the following ASCs:

- a. Aperture;
- b. Return Physical Channel Reception;

- c. Return Sync and Channel Decoding; and
- d. Data Transfer Services.

Figure 5-8 illustrates the ASCs and SCs used in the SLS configuration of the ROCF service.

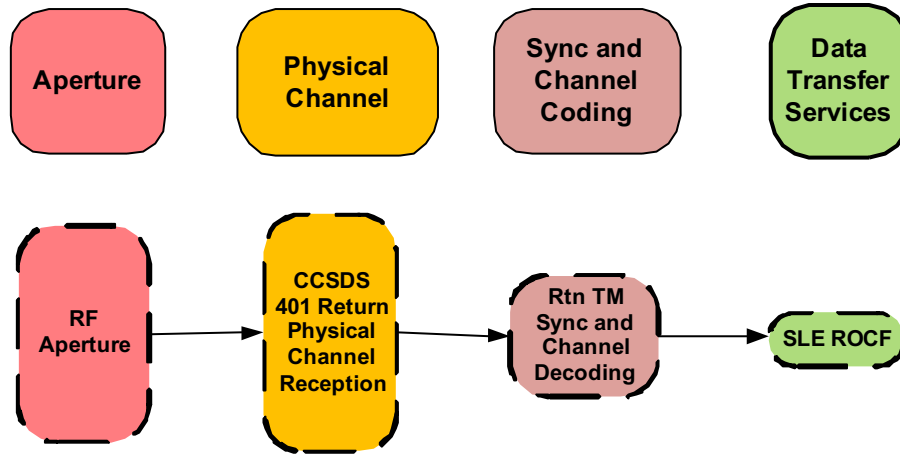

Figure 5-8: SCs Used in ROCF Service

The ROCF service has no choice of service modes and no options.

Table 5-15: ASC Characteristics in ROCF Service

ASC	Future Replaceable	Known Specialization	SAP Port Used	Accessor Port Used
Aperture	Yes	RF Aperture	Return Modulated Waveform (essential)	n/a
Return Physical Channel Reception	Yes	CCSDS 401 Return Physical Channel Reception.	Return Physical Channel Symbols (essential).	Return Modulated Waveform (essential).
Return Sync and Channel Decoding	Yes	Return TM Synchronization and Channel Decoding	Return All Annotated Transfer Frames (specialization)	Return Physical Channel Symbols (essential).
Data Transfer Services	No	SLE ROCF	n/a	Return All Annotated Transfer Frames (specialization).

5.2.5 SLS RETURN UNFRAMED TELEMETRY SERVICE

The IOAG definition of the Return Unframed Telemetry Return Data Delivery service spans two of the service configurations: SLS and retrieval, and the service is treated as three

DRAFT TECHNICAL NOTE CONCERNING THE FUNCTIONAL RESOURCE REFERENCE
MODEL

different services: SLS RUFT service (covering the functions that are performed when the RUFT service is operating in ‘real time’ mode), TM Segment Capture service (covering the functions that are performed to capture the unframed telemetry data for subsequent transfer), and RUFT Retrieval service (covering the functions performed to transfer the unframed telemetry out of the ESLT in ‘complete’ mode).

This section documents the SLS RUFT service. The Telemetry Segment Capture service is addressed in 5.2.6. The RUFT Retrieval service is addressed in 6.1.3.

The SLS RUFT service is configured using the following ASCs:

- a. Aperture;
- b. Return Physical Channel Reception;
- c. Return Sync and Channel Decoding; and
- d. Data Transfer Services.

Figure 5-9 illustrates the ASCs and ASCs used in the SLS RUFT service.

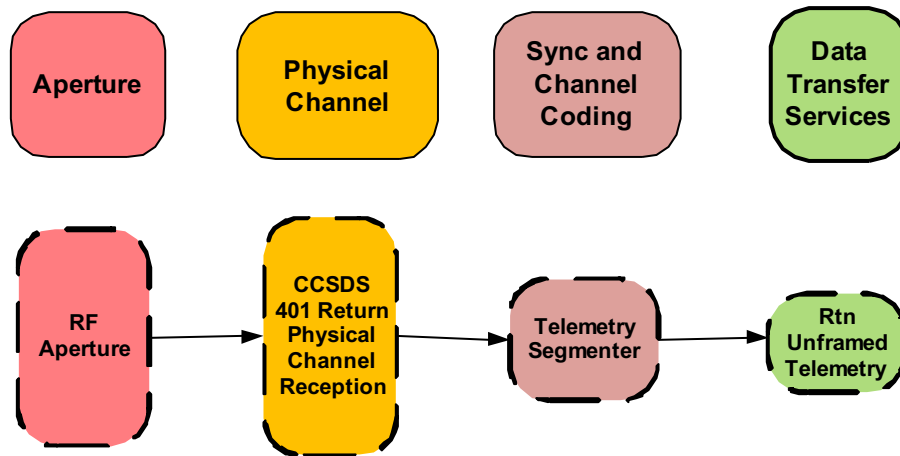

Figure 5-9: SCs Used in SLS RUFT Service

Table 5-16: ASC Characteristics in SLS RUFT Service

ASC	Future Replaceable	Known Specialization	SAP Port Used	Accessor Port Used
Aperture	Yes	RF Aperture	Return Modulated Waveform (essential)	n/a
Return Physical Channel Reception	Yes	CCSDS 401 Return Physical Channel Reception.	Return Physical Channel Symbols (essential).	Return Modulated Waveform (essential).

ASC	Future Replaceable	Known Specialization	SAP Port Used	Accessor Port Used
Return Sync and Channel Decoding	No	Telemetry Segmenter	Return All Transfer Frames (essential) (1)	Return Physical Channel Symbols (essential).
O1: Data Transfer Services	No	Return Unframed Telemetry	n/a	Return All Transfer Frames (specialization) (1)

NOTE 1 - For the purposes of the RUFT service and its associated SCs, the telemetry segments are treated as Transfer Frames. Therefore the Telemetry Segmenter, TM Segment Sink, TM Segment Recording Buffer, and Return Unframed Telemetry SCs use the Return All Transfer Frames ports.

5.2.6 TELEMETRY SEGMENT CAPTURE SERVICE

The TM Segment Capture service is configured using the following ASCs:

- a. Aperture;
- b. Return Physical Channel Reception;
- c. Return Sync and Channel Decoding;
- d. SLS Data Delivery Production; and
- e. Offline Data Storage.

Figure 5-10 illustrates the ASCs and ASCs used in the TM Segment Capture service.

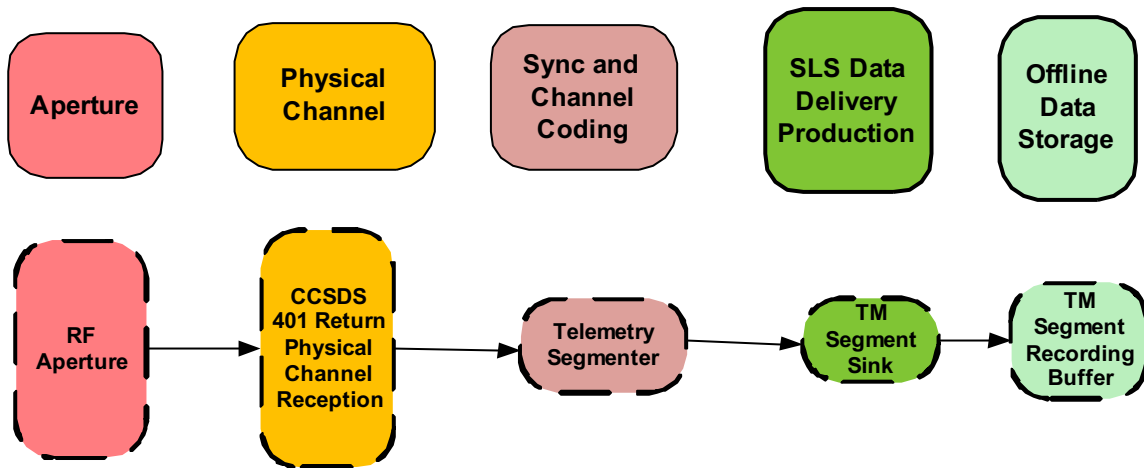

Figure 5-10: SCs Used in TM Segment Capture Service

Table 5-17: ASC Characteristics in TM Segment Capture Service

ASC	Future Replaceable	Known Specialization	SAP Port Used	Accessor Port Used
-----	--------------------	----------------------	---------------	--------------------

DRAFT TECHNICAL NOTE CONCERNING THE FUNCTIONAL RESOURCE REFERENCE
MODEL

ASC	Future Replaceable	Known Specialization	SAP Port Used	Accessor Port Used
Aperture	Yes	RF Aperture	Return Modulated Waveform (essential)	n/a
Return Physical Channel Reception	Yes	CCSDS 401 Return Physical Channel Reception.	Return Physical Channel Symbols (essential).	Return Modulated Waveform (essential).
Return Sync and Channel Decoding	No	Telemetry Segmenter	Return All Transfer Frames (essential)	Return Physical Channel Symbols (essential).
SLS Data Delivery Production	No	TM Segment Sink	Return All TM Segments (specialization)	Return All Transfer Frames (specialization)
Offline Data Storage	No	TM Segment Recording Buffer	n/a	Return All TM Segments (specialization)

5.2.7 RETURN FILE CAPTURE SERVICE

The IOAG definition of the Return File service spans two of the service configurations: SLS and retrieval, and so the service is treated as two different services: Return File Capture service (covering the functions that are performed when the space link is active) and Return File Retrieval service (covering the functions performed to transfer the file out of ESLT storage).

NOTE 1 - The Return File service has not yet been specified. The description in this subsection describes one possible configuration of SCs. The actual Return File service configuration may or may not resemble this strawman description. **The following description is still very much a work in progress, with numerous issues that still need to be worked out.**

NOTE 2 - In this strawman conception, it is assumed that the Return File service can acknowledge receipt of files from space only through CFDP operating in reliable mode, and that in doing so COP-1 is not used.

This section addresses the Return File Capture service. The Return File Retrieval service is addressed in 6.1.4.

The Return File Capture service is configured using the following ASCs:

- a. Aperture;
- b. Return Physical Channel Reception;
- c. Return Sync and Channel Decoding;

- d. Return Sync and Channel Decoding; and
- e. Return Space Link Protocol Reception;
- f. SLS Data Delivery Production;
- g. Offline Data Storage;
- h. Forward Physical Channel Transmission (optional),
- i. Forward Sync and Channel Encoding (optional); and
- j. Forward Space Link Protocol (optional).

Figure 5-4 illustrates the ASCs and SCs used in the SLS configuration of the Return File Capture service.

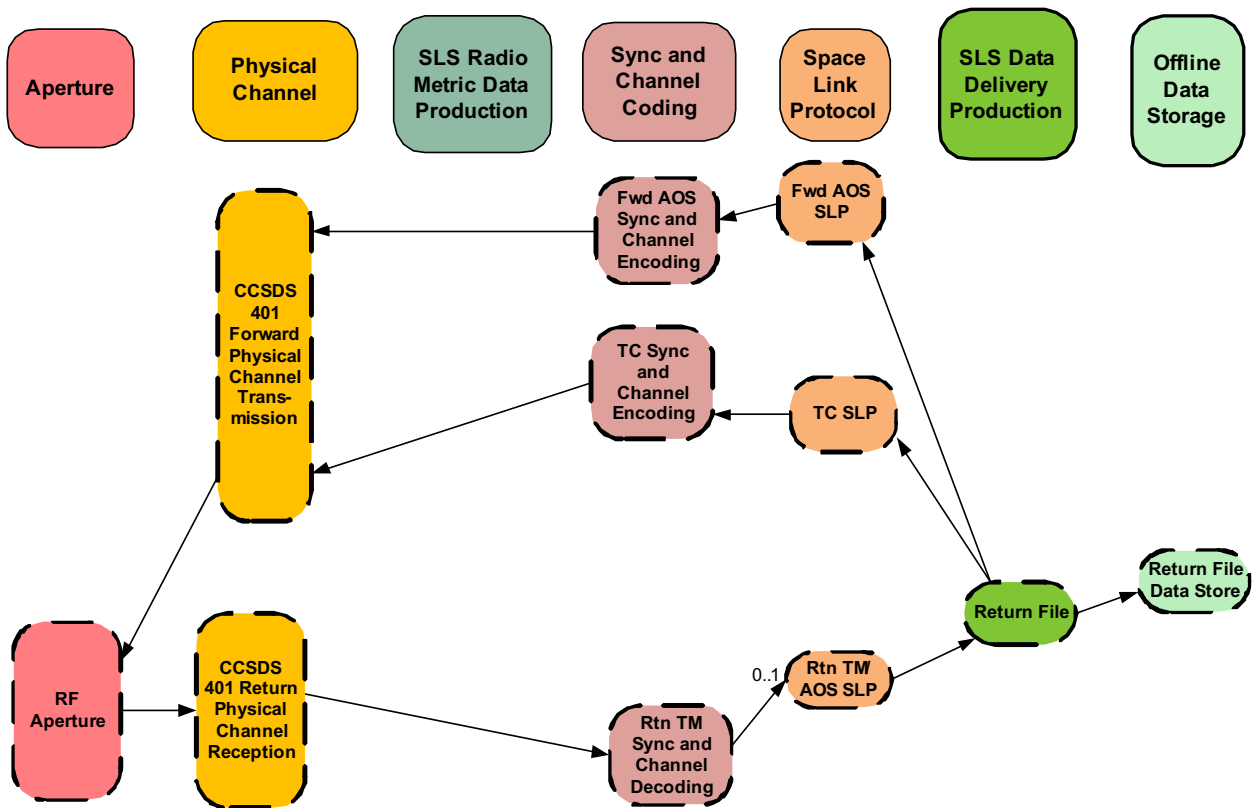

Figure 5-11: SCs Used in Return File Capture Service

Table 5-18: Service Options for Return File Capture Service

Option	Name	Description	Predicate
O1	Reliable CFDP	Files are transmitted via CFDP operating in reliable mode,	
O1.1	AOS Mode	Files are transmitted via CFDP operating in reliable mode, with the acknowledgements over an AOS forward channel	O1

DRAFT TECHNICAL NOTE CONCERNING THE FUNCTIONAL RESOURCE REFERENCE
MODEL

O1.2	TC Mode	Files are transmitted via CFDP operating in reliable mode, with the acknowledgements over a TC forward channel	O1
O1.2A	With Forward Link Status	Transfer of CLTUs is gated based on forward link status information that is reported in the CLCWs of transfer frames received on the return link.	O1.2
O1.2B	COP-1	COP-1 is used for reliable transmission on the forward link.	O1.2

NOTE - If O1 is selected, precisely one of O1.1 and O1.2 must be selected.

NOTE - Either of O1.2A and O1.2B may independently be selected in combination with O1.2.

Table 5-19: ASC Characteristics in Return File Capture Service

ASC	Future Replaceable	Known Specialization	SAP Port Used	Accessor Port Used
Aperture	Yes	RF Aperture	Return Modulated Waveform (essential). O1: Forward Modulated Waveform (essential)	none
Return Physical Channel Reception	Yes	CCSDS 401 Return Physical Channel Reception.	Return Physical Channel Symbols (essential port).	Return Modulated Waveform (essential).
Return Sync and Channel Decoding	Yes	Return TM Synchronization and Channel Decoding	Return All Transfer Frames (essential).	Return Physical Channel Symbols (essential).
Return Space Link Protocol Reception	Yes	Return TM/AOS Space Link Protocol.	Return Packet (essential). O1.2A, O1.2B: CLCW (specialization)	Return All Transfer Frames (essential).

DRAFT TECHNICAL NOTE CONCERNING THE FUNCTIONAL RESOURCE REFERENCE
MODEL

ASC	Future Replaceable	Known Specialization	SAP Port Used	Accessor Port Used
SLS Data Delivery Production	No	Return File Data Delivery Production	Return Space Data File (specialization)	Return Packet (essential). O1: Ack CFDP-PDU (specialization)
Offline Data Storage	No	Return File Data Store	n/a	Return Space Data File (specialization)
O1: Forward Physical Channel Transmission	Yes	CCSDS 401 Forward Physical Channel Transmission	Forward Physical Channel Symbols (essential).	Forward Modulated Waveform (essential).
O1: Forward Sync and Channel Encoding	Yes	O1.1: AOS Sync and Channel Encoding O1.2: TC Sync and Channel Encoding	Forward All Transfer Frames (essential)	Forward Physical Channel Symbols (essential). O1.2A: CLCW (specialization).
O1: Forward Space Link Protocol Transmission	Yes	O1.1: Forward AOS Space Link Protocol O1.2: TC Space Link Protocol	M1: Forward Space Packet (essential) M2: Forward Encapsulation Packet (essential)	Forward All Transfer Frames (essential). O1.2B: CLCW (specialization).

5.3 RADIOMETRIC SERVICES

5.3.1 PRE-VALIDATED RADIOMETRIC DATA CAPTURE SERVICE

IOAG SC#1 defines the Validated Data Radiometric service as:

This Service enables a Control Center to receive the data involved in orbit computation as received and validated by a Ground Tracking Asset. Validated data include traditional and Pseudo-Noise ranging results as well as correlated Delta-DOR data. Such data are provided to a Control Center within files assembled by the Ground Tracking Asset. This Service relies on the following Space Link Interface Standards and Ground Link Interface Standards.

- Radio Frequency and Modulation [RFM] limited to module for “Radio Metric”

DRAFT TECHNICAL NOTE CONCERNING THE FUNCTIONAL RESOURCE REFERENCE MODEL

- Pseudo-Noise (PN) Ranging Systems [PNR]
- Delta-Differential One Way Ranging (Delta-DOR) Operations [DDORO]
- CSTS Offline Radio Metric Service [CORS] over
- CSTS Transfer File Service [CFXS]

Remark - The two CSTS File Services listed above are “to be written”. It is assumed that a generic transfer file service allowing to transfer files between two units, i.e. [CFXS], will be available and - on top of this generic service – more “specialized” file services will allow requesting the dedicated processing for the file being transferred. In this case, it is expected that the CSTS Offline Radio Metric Service will allow the Ground Tracking Asset to inform the Control Center about applied processing and file contents (i.e. Tracking Data Messages (TDM) according to the [TDM] standard specifying a format for use in exchanging spacecraft tracking data).

The IOAG definition of the Validated Data Radiometric service spans two of the service configurations: SLS and retrieval, and so the service is treated as two different services: Pre-validated Radiometric Data Capture service (covering the functions that are performed when the space link is active) and Validated Radiometric Data Retrieval service (covering the functions performed to transfer the file out of the ESLT).

This section addresses the Pre-validated Radiometric Data Capture service. The Validated Radiometric Data Retrieval service is addressed in 6.2.1.

The Pre-validated Radiometric Data Capture service is configured using the following ASCs:

- a. Aperture;
- b. Forward Physical Channel Transmission (optional);
- c. Return Physical Channel Reception;
- d. SLS Radiometric Data Production; and
- e. Offline Data Storage..

Figure 5-12 illustrates the ASCs and SCs used in the SLS configuration of the Pre-validated Radiometric Data Capture service.

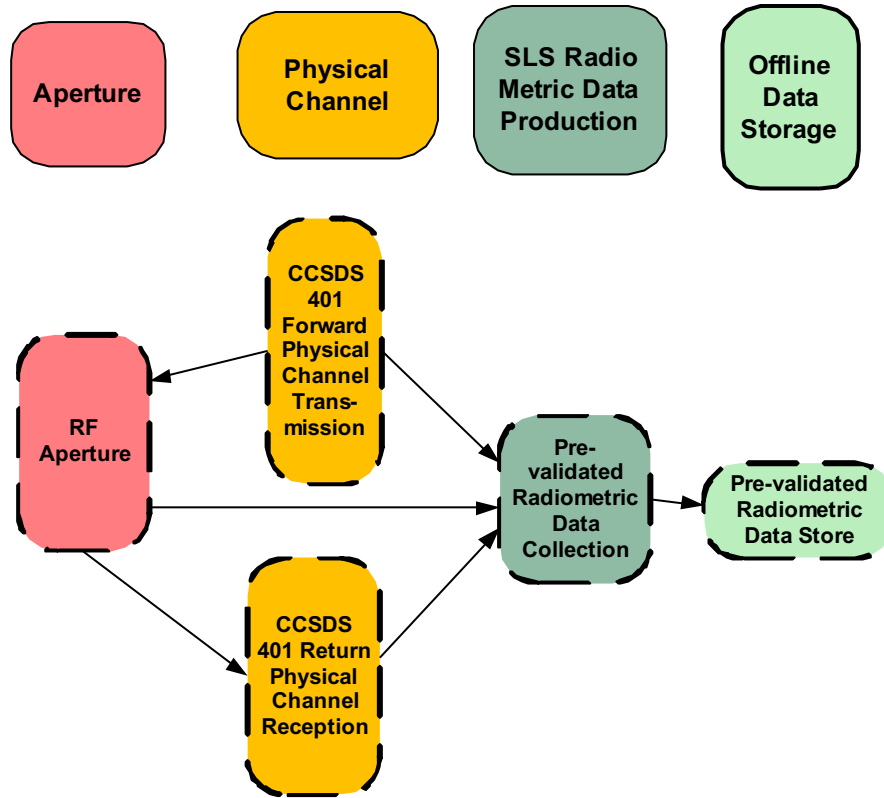

Figure 5-12: SCs Used in Pre-validatedData Radiometric Data Capture Service

Table 5-20: Service Options for Pre-validated Radiometric Data Capture Service

Option	Name	Description	Predicate
O1	Ranging		
O2	Pointing Angles		
O3.1	One-way Doppler		
O3.2	Two-way Doppler		

NOTE - At least one of O1, O2, and either O3.1 or O3.2 must be included.

Table 5-21: ASC Characteristics in Pre-validated Radiometric Data Capture Service

ASC	Future Replaceable	Known Specialization	SAP Port Used	Accessor Port Used

DRAFT TECHNICAL NOTE CONCERNING THE FUNCTIONAL RESOURCE REFERENCE
MODEL

ASC	Future Replaceable	Known Specialization	SAP Port Used	Accessor Port Used
Aperture	Yes	RF Aperture	Return Modulated Waveform (essential) O1, O3.2: Forward Modulated Waveform (essential) O2: Pointing Angles (specialization)	n/a
Return Physical Channel Reception	Yes	CCSDS 401 Return Physical Channel Reception.	Range and Doppler (essential) Receive Frequency (essential)	Return Modulated Waveform (essential) O1, O3.2: Ranging Signal Timing (essential).
O1, O3.2: Forward Physical Channel Transmission	Yes	CCSDS 401 Forward Physical Channel Transmission.	Transmit Frequency (essential). Ranging Signal Timing (essential)	Forward Modulated Waveform (essential).
SLS Radiometric Data Production	No	Pre-Validated Radiometric Data Collection	Pre-Validated Radiometric Data (specialization)	Range and Doppler (essential). Receive Frequency (essential) O2: Pointing Angles (specialization) O1, O3.2: Transmit Frequency (essential).
Offline Data Storage	No	Pre-Validated Radiometric Data Store	n/a	Pre-Validated Radiometric Data (specialization)

ALTERNATE APPROACH using different options and generic “Forward Radiometric Data” and “Return Radiometric Data” ports.

Table 5-22: ALTERNATE Service Options for Pre-validated Radiometric Data Capture Service

Option	Name	Description	Predicate
O1	Forward Radiometric	Radiometric data to be collected includes data requiring the use of the forward physical channel, including (but not limited to) transmit frequency, range, and two-way Doppler.	
O2	Return Radiometric	Radiometric data to be collected includes data requiring the use of the return physical channel, including (but not limited to) receive frequency, range, and two-way Doppler.	
O3	Pointing Angles	Radiometric data to be collected includes aperture pointing angles.	

NOTE - At least one of O1, O2, or O3 must be included.

NOTE - A radiometric configuration may implement the Forward Radiometric option (O1) but not the Return Radiometric option (O2) in cases of 3-wat Doppler tracking, where the configuration is for the ESLT that generates the forward link. In such a configuration, the relevant forward link data (e.g., the transmit frequency) can be supplied to the ESLT that receives the return link (and generates the Doppler measurements) via the tracking data service, where the receiving ESLT is configured to be a user of the tracking data service. SUCH A RECEIVING ESLT CONFIGURATION IS NOT YET INCLUDED IN THIS MODEL!

Table 5-23: ALTERNATE ASC Characteristics in Pre-validated Radiometric Data Capture Service

ASC	Future Replaceable	Known Specialization	SAP Port Used	Accessor Port Used
Aperture	Yes	RF Aperture	O2: Return Modulated Waveform (essential) O1: Forward Modulated Waveform (essential) O3: Pointing Angles (specialization)	n/a

DRAFT TECHNICAL NOTE CONCERNING THE FUNCTIONAL RESOURCE REFERENCE
MODEL

ASC	Future Replaceable	Known Specialization	SAP Port Used	Accessor Port Used
O2: Return Physical Channel Reception	Yes	CCSDS 401 Return Physical Channel Reception.	Return Radiometric Data (essential)	Return Modulated Waveform (essential) O1: Forward Radiometric Data (essential).
O1: Forward Physical Channel Transmission	Yes	CCSDS 401 Forward Physical Channel Reception.	Forward Radiometric Data (essential).	Forward Modulated Waveform (essential)
SLS Radiometric Data Production	No	Raw Radiometric Data Collection	Raw Radiometric Data (specialization)	O2: Return Radiometric Data (essential) O3: Pointing Angles (specialization) O1: Forward Radiometric Data (essential).
Offline Data Storage	No	Raw Radiometric Data Store	n/a	Raw Radiometric Data (specialization)

5.3.2 SLS RAW RADIOMETRIC DATA SERVICE

The IOAG definition of the Raw Data Radiometric Data Delivery service spans two of the service configurations: SLS and retrieval, and the service is treated as three different services: SLS Raw Radiometric Data service (covering the functions that are performed when TDM segments containing raw radiometric data are delivered through the Tracking Data CSTS operating in ‘real time’ mode), TDM Segment Capture service (covering the functions that are performed to capture the TDM segments for subsequent transfer), and Raw Radiometric Data Retrieval service (covering the functions performed to transfer the TDM segments out of the ESLT through the Tracking Data CSTS operating in ‘complete’ mode).

This section addressed the SLS Raw Radiometric Data service. The TDM Segment Capture service is addressed in 5.3.3. The Raw Radiometric Data Retrieval service is addressed in 6.2.2.

The SLS Raw Radiometric Data service is configured using the following ASCs:

- a. Aperture;
- b. Forward Physical Channel Transmission;
- c. Return Physical Channel Reception;
- d. SLS Radiometric Production;
- e. Data Transfer Services.

Figure 5-13 illustrates the ASCs and SCs used in the SLS Raw Radiometric Data service.

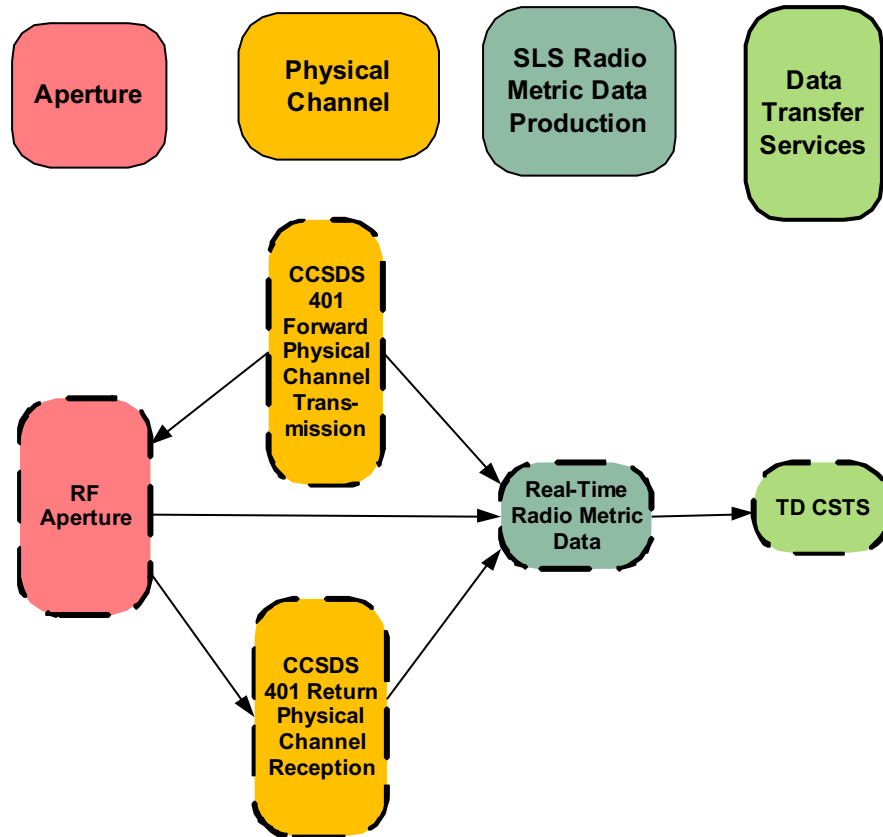

Figure 5-13: SCs Used in SLS Raw Radiometric Data Service

Table 5-24: Service Options for SLS Raw Radiometric Data Service

Option	Name	Description	Predicate
O1	Ranging		
O2	Pointing Angles		
O3.1	One-way Doppler		
O3.2	Two-way		

DRAFT TECHNICAL NOTE CONCERNING THE FUNCTIONAL RESOURCE REFERENCE
MODEL

Option	Name	Description	Predicate
	Doppler		

NOTE - At least one of O1, O2, and either O3.1 or O3.2 must be included.

NOTE - At most one of O3.1 and O3.2 may be included.

Table 5-25: ASC Characteristics in SLS Raw Radiometric Data Service

ASC	Future Replaceable	Known Specialization	SAP Port Used	Accessor Port Used
Aperture	Yes	RF Aperture	Return Modulated Waveform (essential) O1, O3.2: Forward Modulated Waveform (essential) O2: Pointing Angles (specialization)	n/a
Return Physical Channel Reception	Yes	CCSDS 401 Return Physical Channel Reception.	Range and Doppler (essential) Receive Frequency (essential)	Return Modulated Waveform (essential) O1, O3.2: Ranging Signal Timing (essential)
O1, O3.2: Forward Physical Channel Transmission	Yes	CCSDS 401 Forward Physical Channel Transmission	Transmit Frequency (essential) Ranging Signal Timing (essential)	Forward Modulated Waveform (essential).
SLS Radiometric Data Production	No	Real-Time Radiometric Data	TDM Segments (specialization)	Range and Doppler (essential) Receive Frequency (essential) O2: Pointing Angles (specialization) O1, O3.2: Transmit Frequency (essential).
Data Transfer Services	No	Tracking Data-CSTS	n/a	TDM Segments (specialization)

Table 5-26: ALTERNATE Service Options for SLS Raw Radiometric Data Service

Option	Name	Description	Predicate
O1	Forward Radiometric	Radiometric data to be collected includes data requiring the use of the forward physical channel, including (but not limited to) transmit frequency, range, and two-way Doppler.	
O2	Return Radiometric	Radiometric data to be collected includes data requiring the use of the return physical channel, including (but not limited to) receive frequency, range, and two-way Doppler.	
O3	Pointing Angles	Radiometric data to be collected includes aperture pointing angles.	
O4	Online	The service includes real-time instances of the Tracking Data CSTS	
O5	Storage	Tracking data is to be stored for subsequent retrieval	

NOTE - At least one of O1, O2, or O3 must be included.

NOTE - At least one of O4 and O5 must be included.

Table 5-27: ASC Characteristics in SLS Raw Radiometric Data Service

ASC	Future Replaceable	Known Specialization	SAP Port Used	Accessor Port Used
Aperture	Yes	RF Aperture	O2: Return Modulated Waveform (essential) O1: Forward Modulated Waveform (essential) O3: Pointing Angles (specialization)	n/a
O2: Return Physical Channel Reception	Yes	CCSDS 401 Return Physical Channel Reception.	Return Radiometric Data (essential).	Return Modulated Waveform (essential) O1: Forward Radiometric Data (essential)

DRAFT TECHNICAL NOTE CONCERNING THE FUNCTIONAL RESOURCE REFERENCE
MODEL

ASC	Future Replace-able	Known Specialization	SAP Port Used	Accessor Port Used
O1: Forward Physical Channel Transmission	Yes	CCSDS 401 Forward Physical Channel Reception.	Forward Radiometric Data (essential).	Forward Modulated Waveform (essential).
SLS Radiometric Data Production	No	Real-Time Radiometric Data	TDM Segments (specialization)	O2: Return Radiometric Data (essential) O3: Pointing Angles (specialization) O1: Forward Radiometric Data (essential).
O5: Offline Data Storage		TDM Recording Buffer	n/a	TDM Segments (specialization)
O4: Data Transfer Services	No	TD-CSTS	n/a	TDM Segments (specialization)

5.3.3 TDM SEGMENT CAPTURE SERVICE

The TDM Segment Capture service is configured using the following ASCs:

- a. Aperture;
- b. Forward Physical Channel Transmission;
- c. Return Physical Channel Reception;
- d. SLS Radiometric Production; and
- e. Offline Data Storage.

Figure 5-13 illustrates the ASCs and SCs used in the SLS configuration of the TDM Segment Capture service.

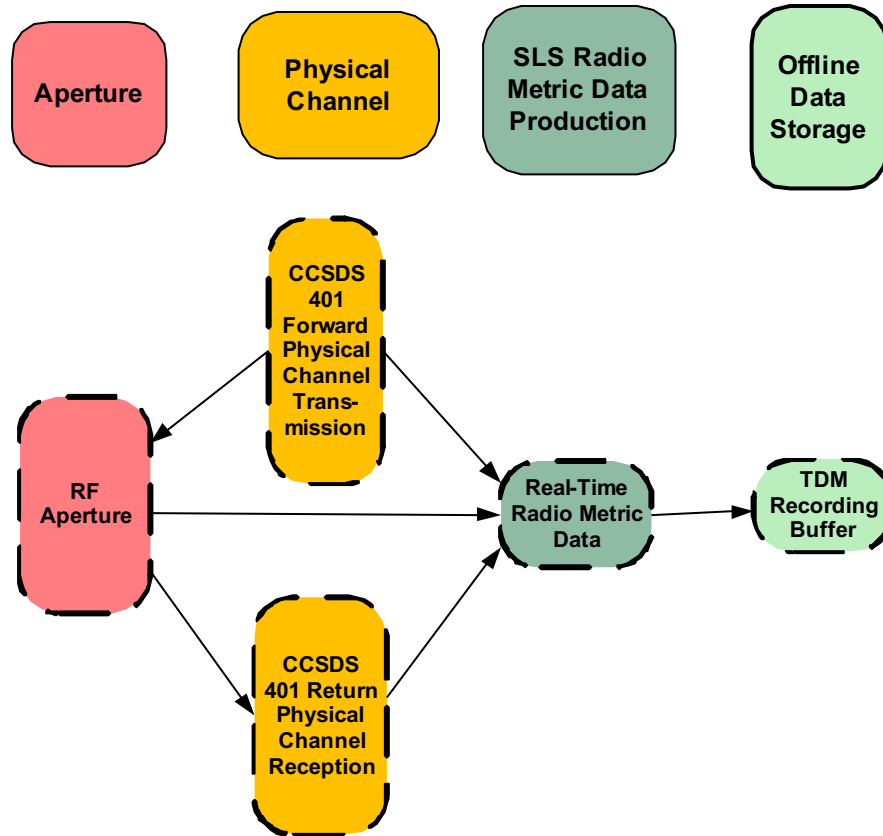

Figure 5-14: SCs Used in TDM Segment Capture Service

Table 5-28: Service Options for TDM Segment Capture Service

Option	Name	Description	Predicate
O1	Ranging		
O2	Pointing Angles		
O3.1	One-way Doppler		
O3.2	Two-way Doppler		

NOTE - At least one of O1, O2, and either O3.1 or O3.2 must be included.

NOTE - At most one of O3.1 and O3.2 may be included.

Table 5-29: ASC Characteristics in TDM Segment Capture Service

ASC	Future Replaceable	Known Specialization	SAP Port Used	Accessor Port Used
Aperture	Yes	RF Aperture	Return Modulated Waveform (essential) O1, O3.2: Forward Modulated Waveform (essential) O2: Pointing Angles (specialization)	n/a
Return Physical Channel Reception	Yes	CCSDS 401 Return Physical Channel Reception.	Range and Doppler (essential) Receive Frequency (essential)	Return Modulated Waveform (essential) Ranging Signal Timing (essential)
O1, O3.2: Forward Physical Channel Transmission	Yes	CCSDS 401 Forward Physical Channel Transmission	Transmit Frequency (essential) Ranging Signal Timing (essential)	Forward Modulated Waveform (essential).
SLS Radiometric Data Production	No	Real-Time Radiometric Data	TDM Segments (specialization)	Range and Doppler (essential) Receive Frequency (essential) O2: Pointing Angles (specialization) O1, O3.2: Transmit Frequency (essential).
O5: Offline Data Storage		Telemetry Segment Recording Buffer	Buffered TDM Segments (specialization)	TDM Segments (specialization)

Table 5-30: ALTERNATE Service Options for TDM Segment Capture Service

Option	Name	Description	Predicate
O1	Forward Radiometric	Radiometric data to be collected includes data requiring the use of the forward physical channel, including (but not limited to) transmit frequency, range, and two-way Doppler.	

DRAFT TECHNICAL NOTE CONCERNING THE FUNCTIONAL RESOURCE REFERENCE
MODEL

Option	Name	Description	Predicate
O2	Return Radiometric	Radiometric data to be collected includes data requiring the use of the return physical channel, including (but not limited to) receive frequency, range, and two-way Doppler.	
O3	Pointing Angles	Radiometric data to be collected includes aperture pointing angles.	
O4	Online	The service includes real-time instances of the Tracking Data CSTS	
O5	Storage	Tracking data is to be stored for subsequent retrieval	

NOTE - At least one of O1, O2, or O3 must be included.

NOTE - At least one of O4 and O5 must be included.

Table 5-31: ASC Characteristics in TDM Segment Capture Service

ASC	Future Replace-able	Known Specialization	SAP Port Used	Accessor Port Used
Aperture	Yes	RF Aperture	O2: Return Modulated Waveform (essential) O1: Forward Modulated Waveform (essential) O3: Pointing Angles (specialization)	n/a
O2: Return Physical Channel Reception	Yes	CCSDS 401 Return Physical Channel Reception.	Return Radiometric Data (essential).	Return Modulated Waveform (essential) O1: Forward Radiometric Data (essential)
O1: Forward Physical Channel Transmission	Yes	CCSDS 401 Forward Physical Channel Reception.	Forward Radiometric Data (essential).	Forward Modulated Waveform (essential).

DRAFT TECHNICAL NOTE CONCERNING THE FUNCTIONAL RESOURCE REFERENCE
MODEL

ASC	Future Replace-able	Known Specialization	SAP Port Used	Accessor Port Used
SLS Radiometric Data Production	No	Real-Time Radiometric Data	TDM Segments (specialization)	O2: Return Radiometric Data (essential) O3: Pointing Angles (specialization) O1: Forward Radiometric Data (essential).
O5: Offline Data Storage		TDM Recording Buffer	n/a	TDM Segments (specialization)
O4: Data Transfer Services	No	TD-CSTS	n/a	TDM Segments (specialization)

5.3.4 DELTA-DOR RADIOMETRIC DATA CAPTURE SERVICE

The IOAG definition of the Delta DOR service spans two of the service configurations: SLS and retrieval, and so the service is treated as two different services: Delta-DOR Radiometric Data Capture service (covering the functions that are performed when the space link is active) and Delta-DOR Radiometric Data Retrieval service (covering the functions performed to transfer the file out of the ESLT).

This section addresses the Delta-DOR Radiometric Data Capture service. The Delta-DOR Radiometric Data Retrieval service is addressed in 6.2.3.

The Delta-DOR Radiometric Data Capture service is configured using the following ASCs:

- a. Aperture;
- b. Return Physical Channel Reception;
- c. SLS Radiometric Production; and
- d. Offline Data Storage.

Figure 5-15 illustrates the ASCs and SCs used in the SLS configuration of the Delta-DOR Radiometric Data Capture service.

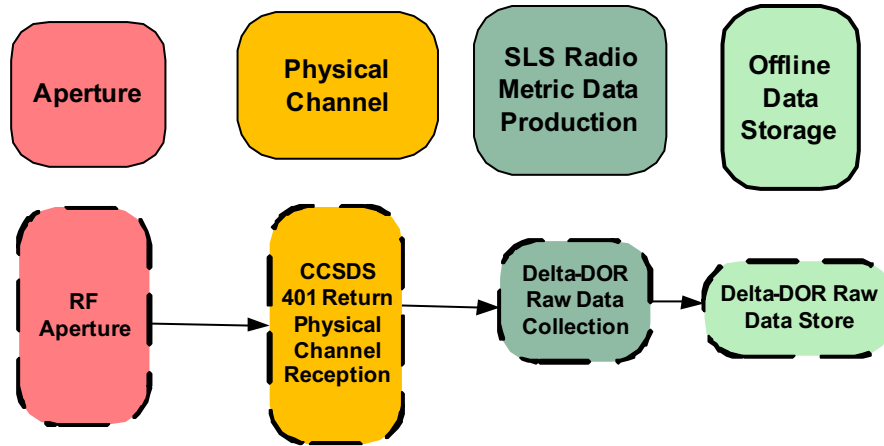

Figure 5-15: SCs Used in Delta-DOR Radiometric Data Capture Service

Table 5-32: ASC Characteristics in Delta-DOR Data Radiometric Data Capture Service

ASC	Future Replaceable	Known Specialization	SAP Port Used	Accessor Port Used
Aperture	Yes	RF Aperture	Return Modulated Waveform (essential) Forward Modulated Waveform (essential)	n/a
Return Physical Channel Reception	Yes	CCSDS 401 Return Physical Channel Reception.	DOR Tones (specialization)	Return Modulated Waveform (essential).
SLS Radiometric Data Production	No	Delta-DOR Data Collection	Raw-formatted D-DOR Data	DOR Tones (specialization).
Offline Data Storage	No	Delta-DOR Raw Data Store	Return File (specialization)	Raw-formatted D-DOR Data

5.3.5 OPEN LOOP DATA CAPTURE SERVICE

Open Loop Recording is not listed explicitly in the IOAG SC#1, but its functionality is included in the IOAG Delta-DOR Radiometric service. Open Loop Recording is treated as a separate service in this Technical Note because its functional resources have been included in the SANA FR type registry.

The purpose of Open Loop Recording is to convert analog RF waveform data into a digitized signal that is recorded for subsequent analysis. The service consists solely of the digitizing

and recording functions; the subsequent retrieval and analysis is done by non-standard means.

Open Loop Recording is supported by two services: Open Loop Data Capture service (covering the functions that are performed when the space link is active) and Open Loop Data Retrieval service (covering the functions performed to transfer the file out of the ESLT).

This section addresses the Open Loop Data Capture service. The Open Loop Data Retrieval service is addressed in 6.2.4.

The Open Loop Data Capture service is configured using the following ASCs:

- e. Aperture;
 - a. Return Physical Channel Reception;
 - b. SLS Radiometric Production; and
 - c. Offline Data Storage.

Figure 5-16 illustrates the ASCs and SCs used in the SLS configuration of the Open Loop Data Capture service.

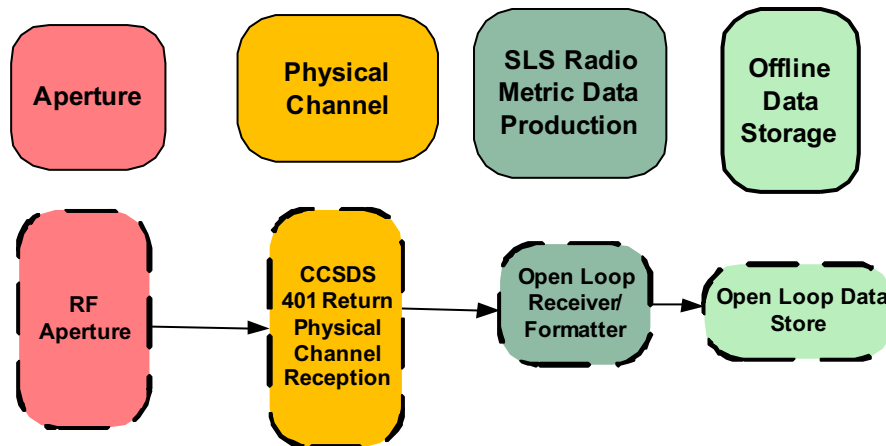

Figure 5-16: SCs Used in Open Loop Data Capture Service

Table 5-33: ASC Characteristics in Open Loop Data Capture Service

ASC	Future Replaceable	Known Specialization	SAP Port Used	Accessor Port Used
Aperture	Yes	RF Aperture	Return Modulated Waveform (essential) Forward Modulated Waveform (essential)	n/a

DRAFT TECHNICAL NOTE CONCERNING THE FUNCTIONAL RESOURCE REFERENCE
MODEL

ASC	Future Replaceable	Known Specialization	SAP Port Used	Accessor Port Used
Return Physical Channel Reception	Yes	CCSDS 401 Return Physical Channel Reception.	Analog Waveform (essential).	Return Modulated Waveform (essential).
SLS Radiometric Data Production	No	Open Loop Receiver/Formatter	Formatted Open Loop Data	Analog Waveform (specialization).
Offline Data Storage	No	Open Loop Data Store	n/a	Formatted Open Loop Data

6 SERVICE PROFILES FOR SERVICES IN RETRIEVAL CONFIGURATIONS

Table 6-1 summarizes the ASCs that are used by each Retrieval configuration service.

The following subsections map each of the retrieval configuration services to the SCs that participate in the production and/or provision of that service. For each service, each ASC that is associated with that service and the existing SC(s) that apply are identified. Any constraints with respect to specific specializations are noted, and the specific service access points used in the configuration of that service are identified.

Table 6-1: Abstract Service Components Used in the Retrieval Configuration Services

ASC -> ----- service v	Offline Data Storage	Data Transfer Services
RAF Retrieval	M	M
RCF Retrieval	M	M
RUFT Retrieval	M	M
Return File Retrieval)	M	M
Validated RM Data Retrieval	M	M
Raw RM Data Retrieval	M	M
Delta-DOR Retrieval	M	M
Open Loop Retrieval	M	M

6.1 RETURN DATA DELIVERY SERVICES

6.1.1 RETURN ALL FRAMES RETRIEVAL SERVICE

The IOAG definition of the Return All Frames Return Data Delivery service spans two of the service configurations: SLS and retrieval. Because the RAF service will have to be treated separately by Service Management for each of these configurations, the service is treated as three different services: SLS RAF service (covering the functions that are performed when the RAF service is operating in ‘online’ mode), Return Frame Capture service (covering the functions that are performed to capture transfer frames for subsequent transfer), and RAF Retrieval service (covering the functions performed to transfer the frames out of the ESLT in ‘offline’ mode).

This SLS RAF service is addressed in 5.2.1. The Return Frame Capture service is described in 5.2.2. This section addresses the RAF Retrieval service.

The Return All Frames Retrieval service is configured using the following ASCs:

- a. Offline Data Storage; and
- b. Data Transfer Services.

Figure 6-1 illustrates the ASCs and SCs used in the Return All Frames Retrieval service.

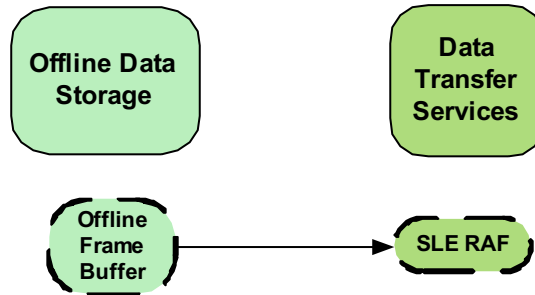

Figure 6-1: SCs Used in Return All Frames Retrieval Service

Table 6-2: ASC Characteristics in Return All Frames Retrieval Service

ASC	Future Replaceable	Known Specialization	SAP Port Used	Accessor Port Used
Offline Data Storage	No	Offline Frame Buffer	Return All Buffered Transfer Frames (specialization)	n/a
Data Transfer Services	No	SLE Return All Frames	n/a	Return All Buffered Transfer Frames (specialization)

6.1.2 RETURN CHANNEL FRAMES RETRIEVAL SERVICE

The IOAG definition of the Return Channel Frames Return Data Delivery service spans two of the service configurations: SLS and retrieval. Because the RCF service will have to be treated separately by Service Management for each of these configurations, the service is treated as three different services: SLS RCF service (covering the functions that are performed when the RCF service is operating in ‘online’ mode), Return Frame Capture service (which has already been addressed in 5.2.2), and RCF Retrieval service (covering the functions performed to transfer the frames out of the ESLT in ‘offline’ mode).

This section addresses the RCF Retrieval service.

The Return Channel Frames Retrieval service is configured using the following ASCs:

- a. Offline Data Storage; and

b. Data Transfer Services.

Figure 6-2 illustrates the ASCs and SCs used in the Return Channel Frames Retrieval service.

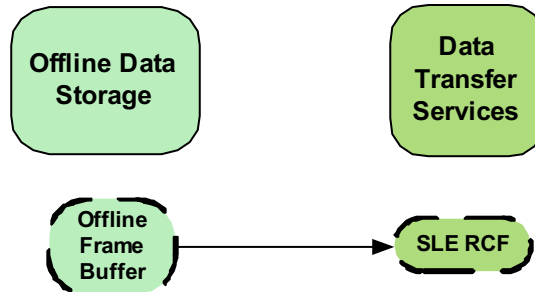

Figure 6-2: SCs Used in Return Channel Frames Retrieval Service

Table 6-3: ASC Characteristics in Return Channel Frames Retrieval Service

ASC	Future Replaceable	Known Specialization	SAP Port Used	Accessor Port Used
Offline Data Storage	No	Offline Frame Buffer	Return All Buffered Transfer Frames (specialization)	n/a
Data Transfer Services	No	SLE Return Channel Frames	n/a	Return All Buffered Transfer Frames (specialization)

6.1.3 RETURN UNFRAMED TELEMETRY RETRIEVAL SERVICE

This section documents the RUFT Retrieval service. The SLS RUFT service is addressed in 5.2.5. The Telemetry Segment Capture service is addressed in 5.2.6.

The Return Unframed Telemetry Retrieval service is configured using the following ASCs:

- a. Offline Data Storage; and
- b. Data Transfer Services.

Figure 6-3 illustrates the ASCs and SCs used in the Return Unframed Telemetry Retrieval service.

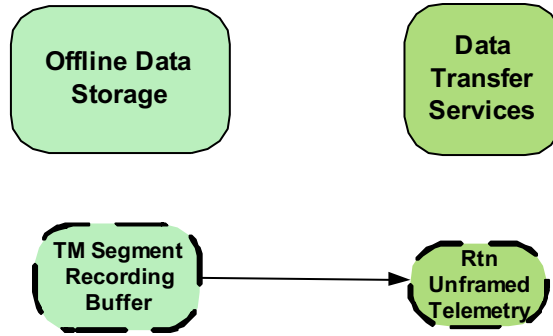

Figure 6-3: SCs Used in Return Unframed Telemetry Retrieval Service

Table 6-4: ASC Characteristics in Return Unframed Telemetry Retrieval Service

ASC	Future Replace-able	Known Specialization	SAP Port Used	Accessor Port Used
Offline Data Storage	No	TM Segment Recording Buffer	Return Buffered Unframed Telemetry Segments (specialization)	n/a
Data Transfer Services	No	Return Unframed Telemetry	n/a	Return Buffered Unframed Telemetry Segments (specialization)

6.1.4 RETURN FILE RETRIEVAL SERVICE

The IOAG definition of the Return File service spans two of the service configurations: SLS and retrieval, and so the service is treated as two different services: Return File Capture service (covering the functions that are performed when the space link is active) and Return File Retrieval service (covering the functions performed to transfer the file out of ESLT storage).

This section addresses the Return File Retrieval service. The Return File Capture service is addressed in 6.1.4.

The Return File Retrieval service is configured using the following ASCs:

- a. Offline Data Storage; and
- b. Data Transfer Services.

Figure 6-4 illustrates the ASCs and SCs used in the Return File Retrieval service.

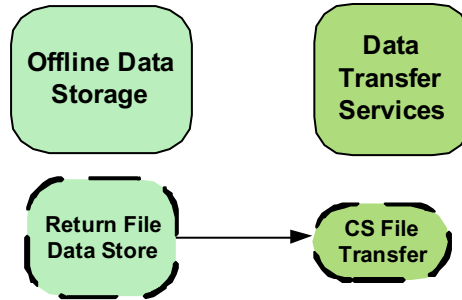

Figure 6-4: SCs Used in Return File Retrieval Service

Table 6-5: ASC Characteristics in Return File Retrieval Configuration

ASC	Future Replace-able	Known Specialization	SAP Port Used	Accessor Port Used
Offline Data Storage	No	Return File Data Store	Return File (specialization)	n/a
Data Transfer Services	No	Cross Support File Transfer Service	n/a	Return File (specialization) (1)

6.2 RADIOMETRIC SERVICES

6.2.1 VALIDATED RADIOMETRIC DATA RETRIEVAL SERVICE

The IOAG definition of the Validated Data Radiometric service spans two of the service configurations: SLS and retrieval, and so the service is treated as two different services: Pre-validated Radiometric Data Capture service (covering the functions that are performed when the space link is active) and Validated Radiometric Data Retrieval service (covering the functions performed to transfer the file out of the ESLT).

This section addresses the Validated Radiometric Data Retrieval service. The Pre-validated Radiometric Data Capture service is addressed in 6.2.1.

The Validated Radiometric Data Retrieval service is configured using the following ASCs:

- a. Offline Data Storage; and
- b. Data Transfer Services.

Figure 6-5 illustrates the ASCs and SCs used in the Retrieval configuration of the Validated Radiometric Data Retrieval service.

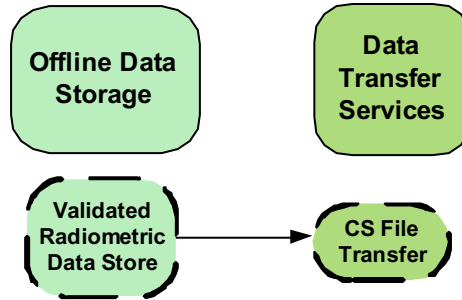

Figure 6-5: SCs Used in Validated Radiometric Data Retrieval Service

Table 6-6: ASC Characteristics in Validated Radiometric Data Retrieval Service

ASC	Future Replace-able	Known Specialization	SAP Port Used	Accessor Port Used
Offline Data Storage	No	Validated Radiometric Data Store	Return File (specialization) (1)	n/a
Data Transfer Services	No	Cross Support File Transfer Service	n/a	Return File (specialization) (1)

6.2.2 RAW DATA RADIOMETRIC SERVICE

The IOAG definition of the Raw Data Radiometric Data Delivery service spans two of the service configurations: SLS and retrieval, and the service is treated as three different services: SLS Raw Radiometric Data service (covering the functions that are performed when TDM segments containing raw radiometric data are delivered through the Tracking Data CSTS operating in ‘real time’ mode), TDM Segment Capture service (covering the functions that are performed to capture the TDM segments for subsequent transfer), and Raw Radiometric Data Retrieval service (covering the functions performed to transfer the TDM segments out of the ESLT through the Tracking Data CSTS operating in ‘complete’ mode).

This section addressed the Raw Radiometric Data Retrieval service. The SLS Raw Radiometric Data service is addressed in 5.3.2. The TDM Segment Capture service is addressed in 5.3.3.

The Raw Radiometric Data Retrieval service is configured using the following ASCs:

- a. Offline Data Storage; and
- b. Data Transfer Services.

Figure 6-6 illustrates the ASCs and SCs used in the Raw Radiometric Data Retrieval service.

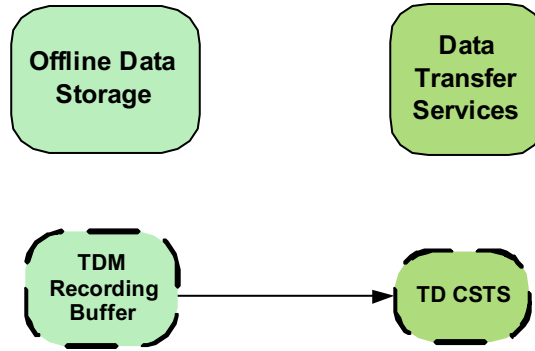

Figure 6-6: SCs Used in Raw Radiometric Data Retrieval Service

Table 6-7: ASC Characteristics in Raw Radiometric Data Retrieval Service

ASC	Future Replace-able	Known Specialization	SAP Port Used	Accessor Port Used
Offline Data Storage	No	TDM Recording Buffer	Buffered TDM Segment (specialization)	n/a
Data Transfer Services	No	TD-CSTS	n/a	Buffered TDM Segment (specialization)

6.2.3 DELTA-DOR RADIOMETRIC DATA RETRIEVAL SERVICE

The IOAG definition of the Delta DOR service spans two of the service configurations: SLS and retrieval, and so the service is treated as two different services: Delta-DOR Radiometric Data Capture service (covering the functions that are performed when the space link is active) and Delta-DOR Radiometric Data Retrieval service (covering the functions performed to transfer the file out of the ESLT).

This section addresses the Delta-DOR Radiometric Data Retrieval service. The Delta-DOR Radiometric Data Capture service is addressed in 5.3.4.

The Delta-DOR Radiometric Data Retrieval service is configured using the following ASCs:

- a. Offline Data Storage; and
- b. Data Transfer Services.

Figure 6-7 illustrates the ASCs and SCs used in the Delta-DOR Radiometric Data Retrieval service.

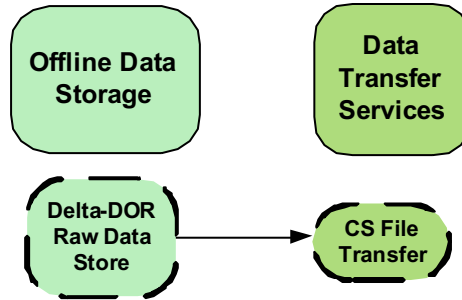

Figure 6-7: SCs Used in Delta-DOR Radiometric Data Retrieval Service

Table 6-8: ASC Characteristics in Delta-DOR Data Radiometric Data Retrieval Service

ASC	Future Replace-able	Known Specialization	SAP Port Used	Accessor Port Used
Offline Data Storage	No	Delta-DOR Raw Data Store	Return File (specialization) (1)	n/a
Data Transfer Services	No	Cross Support File Transfer Service	n/a	Return File (specialization) (1)

6.2.4 OPEN LOOP DATA RETRIEVALSERVICE

This section addresses the Open Loop Data Retrieval service. The Open Loop Data Capture service is addressed in 5.3.5.

In the Retrieval configuration, the Open Loop Data Retrieval service is configured using the following ASCs:

- a. Offline Data Storage; and
- b. Data Transfer Services.

Figure 6-8 illustrates the ASCs and SCs used in the Open Loop Data Retrieval service.

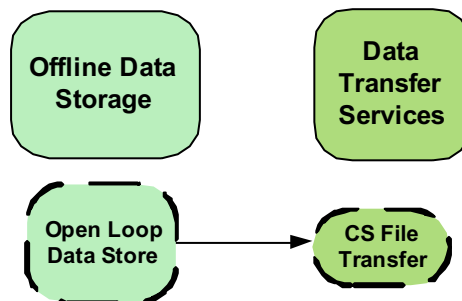

Figure 6-8: SCs Used in Open Loop Data Retrieval Service

Table 6-9: ASC Characteristics in Open Loop Data Retrieval Service

ASC	Future Replace-able	Known Specialization	SAP Port Used	Accessor Port Used
Offline Data Storage	No	Open Loop Data Store	Return File (specialization) (1)	n/a
Data Transfer Services	No	Cross Support File Transfer Service	n/a	Return File (specialization) (1)

7 SERVICE PROFILES FOR SERVICES IN FORWARD OFFLINE CONFIGURATIONS

Table 7-1 summarizes the ASCs that are used by the Forward Offline configuration of each of the appropriate IOAG Service Catalog #1 services.

Section 7.1 maps the Forward File Offline Delivery service to the SCs that participate in the production and/or provision of that service. For each service, each ASC that is associated with that service and the existing SC(s) that apply are identified. Any constraints with respect to specific specializations are noted, and the specific service access points used in the configuration of that service are identified.

Table 7-1: Abstract Service Components Used in the Forward Offline Configurations of the IOAG Services

ASC -> ----- IOAG service v	Offline Data Storage	Data Transfer Services
Forward File Offline Delivery	M	M

7.1 FORWARD DATA DELIVERY SERVICES

7.1.1 FORWARD FILE OFFLINE DELIVERY SERVICE

The IOAG definition of the Forward File service spans two of the service configurations: SLS and forward offline. Because the Forward File service will have to be treated separately by Service Management for each of these configurations, the IOAG Forward File service is treated as two different services: SLS Forward File Transmission service (covering the functions that are performed when the space link is active) and Forward File Offline Delivery service (covering the functions performed to get the file to the ESLT, perhaps before the time that the space link is available).

The SLS Forward File Transmission service is addressed in 5.1.4. This section addresses the Forward File Offline Delivery service.

The Forward File Offline Delivery service is configured using the following ASCs:

- a. Offline Data Storage; and
- b. Data Transfer Services.

Figure 7-1 illustrates the ASCs and SCs used in the Forward Offline configuration of the Forward File service.

DRAFT TECHNICAL NOTE CONCERNING THE FUNCTIONAL RESOURCE REFERENCE MODEL

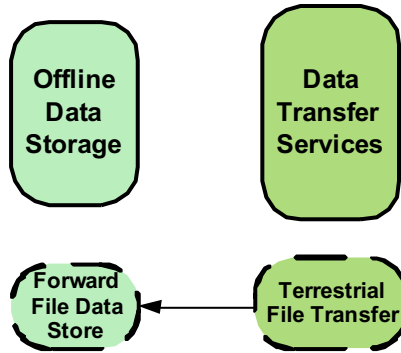

Figure 7-1: SCs Used in Forward File Offline Delivery Service

Table 7-2: ASC Characteristics in Forward File Offline Delivery Service

ASC	Future Replaceable	Known Specialization	SAP Port Used	Accessor Port Used
Offline Data Storage	No	Forward File Data Store	Forward File (specialization) (1)	n/a
Data Transfer Services	No	Cross Support File Transfer Service	n/a	Forward File (specialization)

DRAFT TECHNICAL NOTE CONCERNING THE FUNCTIONAL RESOURCE REFERENCE
MODEL

8 SERVICE AGREEMENT INFORMATION ENTITY

8.1 GENERAL

The Service Agreement Information Entity shall be formatted as an XML instance document in accordance with the schemas identified in Annex ??.

The packaging [is this the best word?] of the Service Agreement Information Entity (e.g., in a file or as the content of an email message) is outside the scope of this Recommended Standard, as are the transfer protocols (e.g., FTP) by which Service Agreement Information Entities are exchanged.

NOTE - CCSDS intends to define a Space Communication Cross Support Management Service in the future. The Management Service will specify (among other things) one (or more) recommended method(s) for packaging Service Agreement Information Entity XML documents and transfer protocols for the automated exchange of those Information Entities. Until the time that the Management Service specification is published, the specification of packaging and transfer protocol is left to the implementers of systems that generate or ingest Service Agreement Information Entities.

8.2 SERVICE AGREEMENT INFORMATION ENTITY CONTENT/STRUCTURE

Figure 8-1 is the UML class diagram for the Service Agreement Information Entity. As shown in the diagram, the classes of the Service Agreement Information Entity are specializations of the classes of the Service Management Information Entity, which is defined in Annex A of reference [**Error! Reference source not found.**].

NOTE - In Figure 8-1, the classes that are colored orange designate classes that are elaborated in other class diagrams. These classes are used by both the Service Agreement Information Entity and the Configuration Profile Information Entity. The associated classes diagrams are located under the specifications of those classes.

DRAFT TECHNICAL NOTE CONCERNING THE FUNCTIONAL RESOURCE REFERENCE MODEL

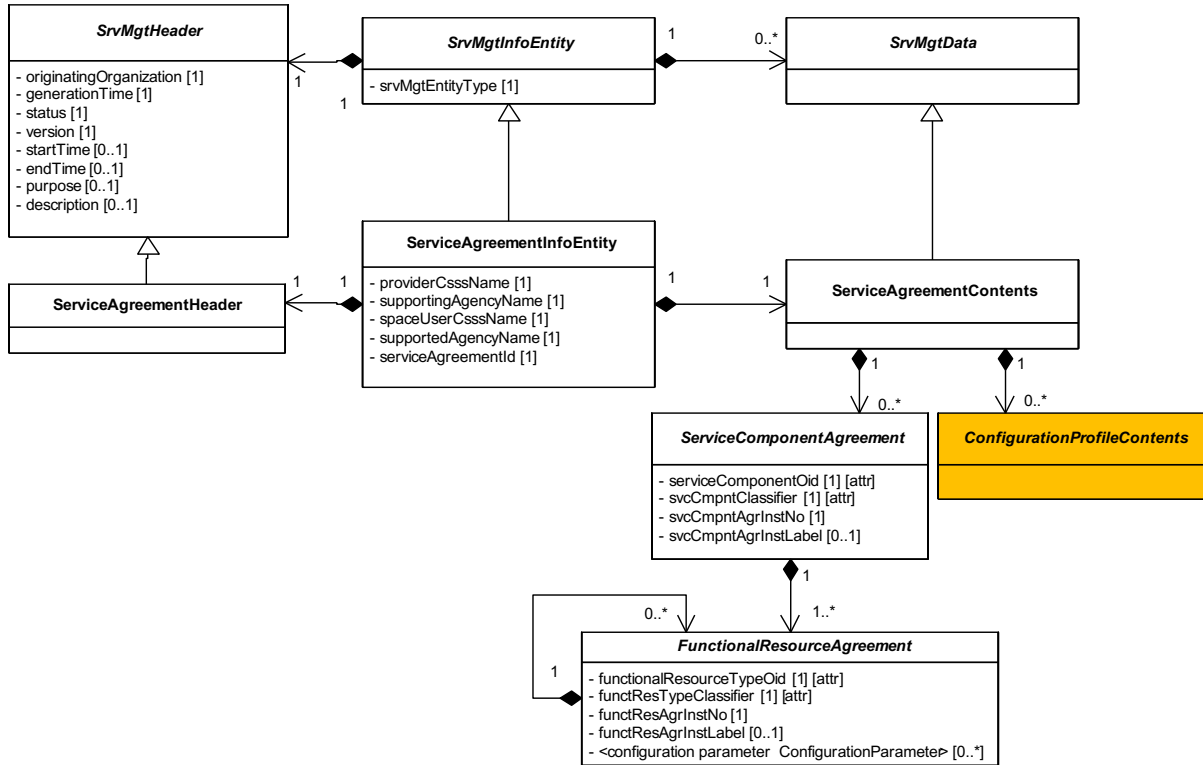

Figure 8-1: Service Agreement Information Entity Class Diagram

NOTE - In the tables in this Recommended Standard, the names of attributes and parameters that are inherited from the parent class and subsequently refined by the specialized class are presented in **underlined bold** font. Parameters that belong exclusively to the specialized class are presented in plain font.

8.2.1 CLASS ServiceAgreementInfoEntity

8.2.1.1 The ServiceAgreementInfoEntity class is mandatory and is a specialization of the the SrvMgtInfoEntity abstract class defined in annex A of reference [Error! Reference source not found.].

8.2.1.2 A Service Agreement Information Entity shall contain one instance of the ServiceAgreementInfoEntity class.

8.2.1.3 Table 8-1 specifies the parameters of the ServiceManagementInfoEntity class.

Table 8-1: Class ServiceAgreementInfoEntity Parameters

Parameter	Description	Data Type	Data Units
<u>srvMgtEntity</u>	As defined for the SrvMgtInfoEntity class in Table A-1 in [Error! Reference source not found.]	String1024 – For the Service Agreement Information Entity the only permitted value for this parameter is “SERVICE_AGREEMENT”	n/a
providerCsssName	The name of the CSSS that will provide the services under the Service Agreement	String 1024	n/a
supportingAgencyName	The name of the space Agent that operates the provider CSSS	String 1024	n/a
spaceUserCsssName	The name of the CSSS that will use the services provided under the Service Agreement	String 1024	n/a
supportedAgencyName	The name of the space Agent that operates the User CSSS	String 1024	n/a
serviceAgreementId	The identifier for the Service Agreement. It is unique in the context of each of the supporting Agency and the supported Agency.	String 1024	n/a

8.2.1.4 A ServiceAgreementInfoEntity class instance shall contain one instances of the ServiceAgreementHeader class (8.2.2) and one instance of the ServiceAgreementContents (8.2.3) class.

8.2.2 CLASS ServiceAgreementHeader

8.2.2.1 The ServiceAgreementHeader class is mandatory and is a specialization of the SrvMgtHeader abstract class.

8.2.2.2 The Service AgreementHeader class does not add any specialization parameters, The parameters for the ServiceAgreementHeader class are as defined for the SrvMgtHeader class in table A-2 of reference [**Error! Reference source not found.**], except for those parameters that are refined in Table 8-2.

Table 8-2: Class ServiceAgreementHeader Parameters

Parameter	Description	DataType	Data Units
<u>status</u>	As defined for the SrvMgtHeader class in Table A-2 in [Error! Reference source not found.].	String32 – For the Service Agreement Information Entity the only permitted value for this parameter are: - “IN_NEGOTIATION”: The Service Agreement is still being developed. It cannot be used operationally. - “OPERATIONAL”: The Service Agreement represents a negotiated set of capabilities that are operationally available from the startTime until the endTime.	n/a
<u>version</u>	As defined for the SrvMgtHeader class in Table A-2 in [Error! Reference source not found.], with the following qualification: the version number may increment only for a Service Agreement with status = “IN_NEGOTIATION”. Any Service Agreement with status = “OPERATIONAL” has the version fixed to 1.	As defined for the SrvMgtHeader class in Table A-2 in [Error! Reference source not found.].	n/a
startTime	As defined for the SrvMgtHeader class in Table A-2 in [Error! Reference source not found.]. This parameter is mandatory when status = “OPERATIONAL”. And specifies the earliest date and time that the Service Agreement may be used for operational purposes.	As defined for the SrvMgtHeader class in Table A-2 in [Error! Reference source not found.].	UTC

DRAFT TECHNICAL NOTE CONCERNING THE FUNCTIONAL RESOURCE REFERENCE
MODEL

Parameter	Description	DataType	Data Units
endTime	As defined for the SrvMgtHeader class in Table A-2 in [Error! Reference source not found.]. This parameter is mandatory when status = “OPERATIONAL”. And specifies the latest date and time that the Service Agreement may be used for operational purposes.	As defined for the SrvMgtHeader class in Table A-2 in [Error! Reference source not found.].	UTC

8.2.3 CLASS ServiceAgreementContents

NOTE - The ServiceAgreementContents has no parameters of its own. It serves as a container for zero or more instances of specializations of the ServiceComponentAgreement class, and zero or one instance of the ConfigurationProfileContents class.

8.2.3.1 The ServiceAgreementContents class is mandatory and is a specialization of the SrvMgtData abstract class.

8.2.3.2 The Service AgreementContents class instance shall contain:

- a. Zero or more instances of concrete specializations of the ServiceComponentAgreement abstract class, and
- b. Zero or one instance of the ConfigurationProfileContents class, as defined in 9.1.3.

NOTE - The optional presence of an instance of the ConfigurationProfileContents class in the Service Agreement allows Provider CSSSes and Missions to defined “ready to go” configuration profiles as part of the Service Agreement. For some providers and missions, the configuration profiles that are contained in the Service Agreement may be the only configuration profiles that are ever used.

8.2.3.3 The Service AgreementContents class instance must contain at least one instance of a concrete specialization of the ServiceComponentAgreement abstract class or one instance of the ConfigurationProfileContents class.

8.2.4 CLASS FunctionalResourceAgreement

NOTE - An instance of the FunctionalResourceAgreement class specifies the ranges or subsets of values of parameters that are permitted in FunctionalResourceProfile instances (see 9.1.11) and Event Sequences that are constrained by that ServiceComponentAgreement instance.

8.2.4.1 The FunctionalResourceAgreement class is a mandatory abstract class. Actual Service Agreements are populated with Service Component-specific specializations of the

DRAFT TECHNICAL NOTE CONCERNING THE FUNCTIONAL RESOURCE REFERENCE
MODEL

FunctionalResourceAgreement class. The core specializations of the FunctionalResourceAgreement class are defined in section **Error! Reference source not found.**

1.1.1.1 Table 8-3 specifies the attributes and parameters that are present in each specialization of the FunctionalResourceAgreement abstract class. *Attributes* are properties of the specialized class itself – their values are fixed for each specialization. Attributes are identified by the notation “[attr]” following the name.

8.2.4.2 Unless otherwise specified, all attributes and parameters in Table 8-3 are mandatory with cardinality 1.

Table 8-3: Class FunctionalResourceAgreement Attributes and Parameters

Attribute/Parameter	Description	DataType	Data Units
functionalResourceTypeOid [attr]	The Object Identifier of the Functional Resource type for which the FunctionalResourceAgreement is specialized. The Functional Resource type OIDs are registered with SANA in the XYZ registry.	OID.	n/a
functiResTypeName [attr]	The Functional Resource type classifier attribute is a string-valued attribute that provides a more human-readable version of the functionalResourceTypeOid. If this attribute is present, it must contain the SANA-registered classifier for the Functional Resource type OID.	String32	n/a
functResAgrInstNo	The Functional Resource Agreement instance number uniquely identifies a Functional Resource Agreement instance within the context of the Service Agreement. This instance number allows multiple Functional Resource Agreements to exist within the same Service Component Agreement.	Positive Integer	n/a

DRAFT TECHNICAL NOTE CONCERNING THE FUNCTIONAL RESOURCE REFERENCE
MODEL

Attribute/Parameter	Description	DataType	Data Units
funcResAgrInstLabel	The Functional Resource Agreement instance label is an optional parameter that allows the Functional Resource Agreement instance to contain a more human-readable “name” for the Functional Resource Agreement instance. The contents of this parameter are not subject to any standardization.	String1024	n/a

8.2.4.3 Specializations of the `FunctionalResourceAgreement` abstract class may contain configuration parameters specific to those specializations. Each configuration parameter shall conform to the `ConfigurationParameter` data type (8.2.5).

8.2.4.4 Specializations of the `FunctionalResourceAgreement` abstract class may contain other specializations of the `FunctionalResourceAgreement` abstract class.

NOTE - The permitted combinations of containment are specific to each `ServiceComponentAgreement` specialization and are defined in section **Error! Reference source not found.**

8.2.5 DATA TYPE ConfigurationParameter

8.2.5.1 Each instance of the `ConfigurationParameter` type shall have a `parameterId` attribute that contains the Object Identifier that is assigned to that parameter.

8.2.5.2 Each instance of the `ConfigurationParameter` type shall have a `parameterClassifier` attribute that contains the character string name that is assigned to that parameter.

8.2.5.3 The value of the `ConfigurationParameter` type shall be one of the following:

- a) A sequence of integers;
- b) A sequence of positive integers;
- c) A sequence of unsigned integers;
- d) A sequence of durations (in seconds);
- e) A sequence of durations (in milliseconds);

DRAFT TECHNICAL NOTE CONCERNING THE FUNCTIONAL RESOURCE REFERENCE
MODEL

- f) A sequence of durations (in microseconds);
- g) A sequence of visible strings;
- h) A sequence of Booleans;
- i) A sequence of octet strings;
- j) A sequence of Real numbers;
- k) A sequence of Time (days and milliseconds since 1958/01/01 00:00:00);
- l) A sequence of Time (days and picoseconds since 1958/01/01 00:00:00);
- m) A sequence of enumerated values;
- n) A sequence of Object Identifiers;
- o) A sequence of any combination of items (a) – (n), above; or
- p) A set of any combination of items (a) – (n), above.

NOTE - The constraints on the value of the `ConfigurationParameter` type match those of the `TypeAndValueComplexQualified` type specified in the Cross Support Transfer Service Specification Framework (reference [**Error! Reference source not found.**]). Constraining configuration parameter values to these types ensures that reconfiguration of those parameters will be possible by a CSTS that uses the `TypeAndValueComplexQualified` type to express parameter values.

9 CONFIGURATION PROFILE INFORMATION ENTITY

9.1 CONFIGURATION PROFILE INFORMATION ENTITY CONTENT/STRUCTURE

Figure 9-1 is the UML class diagram for the Configuration Profile Information Entity. As shown in the diagram, the classes of the Configuration Profile Information Entity are specializations of the classes of the Service Management Information Entity, which is defined in Annex A of reference [**Error! Reference source not found.**].

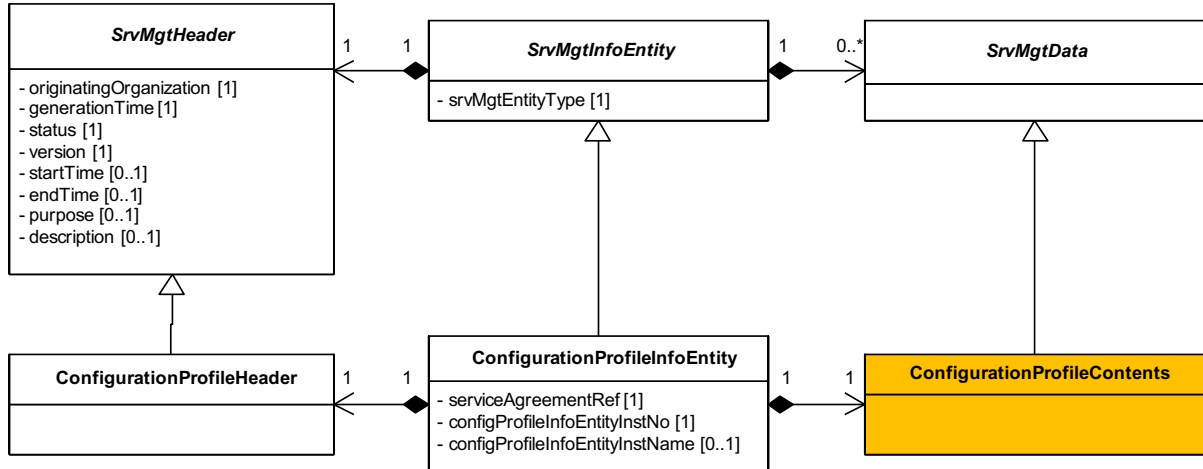

Figure 9-1: Configuration Profile Information Entity Class Diagram

9.1.1 CLASS ConfigurationProfileInfoEntity

9.1.1.1 The ConfigurationProfileInfoEntity class is mandatory and is a specialization of the the SrvMgtInfoEntity abstract class defined in annex A of reference [**Error! Reference source not found.**].

9.1.1.2 Table 9-1 specifies the parameters of the ServiceManagementInfoEntity class.

Table 9-1: Class ServiceAgreementInfoEntity Parameters

Parameter	Description	DataType	Data Units
<u>srvMgtEntity</u>	As defined for the SrvMgtInfoEntity class in Table A-1 in [Error! Reference source not found.]	String1024 – For the Configuration Profile Information Entity the only permitted value for this parameter is “CONFIGURATION_PROFILE”	n/a
serviceAgreementRef	The value of the serviceAgreementId parameter of the Service Agreement that constrains the ServiceComponentProfiles of this information entity.	String 1024	n/a
configProfileInfoEntityInstNo	The Configuration Profile Information Entity instance number uniquely identifies the instance of the Configuration Profile Information Entity among all Configuration Profile Information Entities established in the context of the referenced Service Agreement.	Positive Integer	n/a
configProfileInfoEntityInstName	The optional Configuration Profile Information Entity instance name contains the text name of the instance of the Configuration Profile Information Entity. NOTE - This text name is available for human readability purposes. It should be among all Configuration Profile Information instance names established in the context of the referenced Service Agreement, but it is not required to be so..	String 1024	n/a

9.1.2 CLASS CONFIGURATIONPROFILEHEADER

9.1.2.1 The ConfigurationProfileHeader class is mandatory and is a specialization of the SrvMgtHeader abstract class.

9.1.2.2 The ConfigurationProfileHeader class does not add any specialization parameters, The parameters for the ConfigurationProfileHeader class are as defined for the SrvMgtHeader class in table A-2 of reference [**Error! Reference source not found.**], except for those parameters that are refined in Table 9-2.

Table 9-2: Class ConfigurationProfileHeader Parameters

Parameter	Description	DataType	Data Units
<u>status</u>	As defined for the SrvMgtHeader class in Table A-2 in [Error! Reference source not found.].	String32 – For the Configuration Profile Information Entity the only permitted value for this parameter are: - “IN_NEGOTIATION”: The contents of the Configuration Profile Information Entity are still being developed. It cannot be used operationally. - “OPERATIONAL”: The Configuration Profile represents a negotiated set of profiles that are operationally available from the startTime until the endTime.	n/a
<u>version</u>	As defined for the SrvMgtHeader class in Table A-2 in [Error! Reference source not found.], with the following qualification: the version number may increment only for a Configuration Profile Information Entity with status = “IN_NEGOTIATION”. Any Configuration Profile Information Entity with status = “OPERATIONAL” has the version fixed to 1.	As defined for the SrvMgtHeader class in Table A-2 in [Error! Reference source not found.].	n/a

DRAFT TECHNICAL NOTE CONCERNING THE FUNCTIONAL RESOURCE REFERENCE
MODEL

Parameter	Description	DataType	Data Units
startTime	As defined for the SrvMgtHeader class in Table A-2 in [Error! Reference source not found.]. If this parameter is present, it specifies the earliest date and time that the contents of the Configuration Profile Information Entity may be used for operational purposes.	As defined for the SrvMgtHeader class in Table A-2 in [Error! Reference source not found.].	UTC
endTime	As defined for the SrvMgtHeader class in Table A-2 in [Error! Reference source not found.]. If this parameter is present, it specifies the earliest date and time that the contents of the Configuration Profile Information Entity may be used for operational purposes.	As defined for the SrvMgtHeader class in Table A-2 in [Error! Reference source not found.].	UTC

9.1.3 CLASS ConfigurationProfileContents (Abstract)

9.1.3.1 The ConfigurationProfileContents abstract class is a specialization of the SrvMgtData abstract class.

9.1.3.2 A concrete specialization of the ConfigurationProfileContents abstract class is mandatory in the Configuration Profile Information Entity.

NOTE - Specializations of the ConfigurationProfileContents class may be used in other Information Entities, such as the Service Agreement Information Entity (see 8.2.4). The cardinality of a specialization of the ConfigurationProfileContents class in other Information Entities is specific to each Information Entity type.

9.1.3.3 The ConfigurationProfileContents class has no parameters of its own. It serves as a parent class for the SpaceLinkSessionProfile, RetrievalProfile, ForwardOfflineProfile, and ServiceManagementFunctionsProfile specializations, such that any of those specializations can be substituted for the abstract ConfigurationProfileContents class in Information Entities.

NOTE - The specialization(s) that may substitute for the ConfigurationProfileContents class in an Information Entity is(are) specific to each Information Entity type.

9.1.3.4 An instance of a specialization of the ConfigurationProfileContents class shall contain zero or more instances of specializations of the FlexibilitiesAndConstraints abstract class (see xxx).

DRAFT TECHNICAL NOTE CONCERNING THE FUNCTIONAL RESOURCE REFERENCE
MODEL

Figure 9-2 is the class diagram for the ConfigurationProfileContents class..

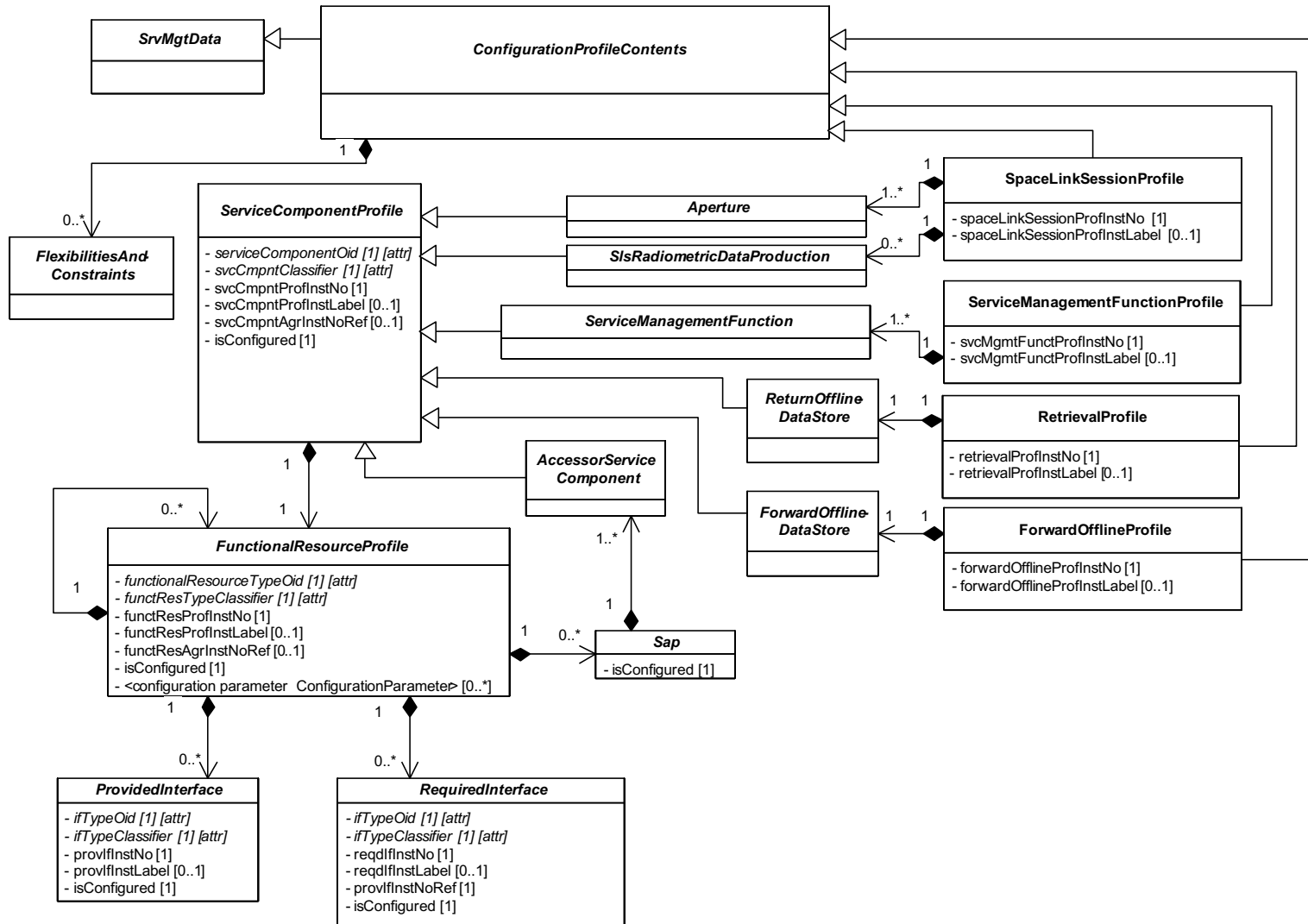

Figure 9-2: Configuration Profile Contents Class Diagram

1.1.2 CLASS SpaceLinkSessionProfile

1.1.2.1 The SpaceLinkSessionProfile class is a specialization of the ConfigurationProfileContents abstract class (9.1.3).

1.1.2.2 Table 9-3 specifies the attributes and parameters that are specific to the SpaceLinkSessionProfile class.

1.1.2.3 Unless otherwise specified, all attributes and parameters in Table 9-3 are mandatory with cardinality 1.

Table 9-3: Class SpaceLinkSessionProfile Attributes and Parameters

Attribute/Parameter	Description	DataType	Data Units
spaceLinkSessionProfInstNo	The Space Link Session Profile instance number uniquely identifies an instance of the Space Link Session Profile class within the context of the Service Agreement.	Positive Integer	n/a
spaceLinkSessionProfInstLabel	The Space Link Session Profile instance label is an optional parameter that allows the Space Link Session Profile instance to have a more human-readable “name”. The contents of this parameter are not subject to any standardization.	String1024	n/a

1.1.2.4 An instance of the SpaceLinkSessionProfile class shall contain one or more instances of specializations of the Aperture abstract class.

1.1.2.5 An instance of the SpaceLinkSessionProfile class shall contain zero or more instances of specializations of the SleRadiometricProduction abstract class.

1.1.3 CLASS Aperture (Abstract)

1.1.3.1 The Aperture abstract class is a specialization of the ServiceComponentProfile abstract class (see **Error! Reference source not found.**).

1.1.3.2 The Aperture class has no parameters of its own. It serves as a parent class for the Service Component Profile specializations associated with the Aperture Abstract Service

Component, such that any of those specializations can be substituted for the abstract Aperture class in a SpaceLinkSessionProfile object.

NOTE - Aperture SCs are root SCs in SLS configurations. Aperture Service Component Profiles are contained directly by SpaceLinkSessionProfile objects and are not contained by any other Service Component Profile types.

9.1.4 CLASS SlsRadiometricDataProduction (Abstract)

9.1.4.1 The SlsRadiometricDataProduction abstract class is a specialization of the ServiceComponentProfile abstract class (see **Error! Reference source not found.**).

9.1.4.2 The SlsRadiometricDataProduction class has no parameters of its own. It serves as a parent class for the Service Component Profile specializations associated with the SLS Radiometric Data Production Abstract Service Component, such that any of those specializations can be substituted for the abstract SlsRadiometricDataProduction class in a SpaceLinkSessionProfile object.

NOTE - SLS Radiometric Data Production Service Component Profiles are contained directly by SpaceLinkSessionProfile objects and are not contained by any other Service Component Profile types.

9.1.4.2.1 CLASS RetrievalProfile

9.1.4.3 The RetrievalProfile class is a specialization of the ServiceComponentProfile abstract class (9.1.3).

9.1.4.4 Table 9-4 specifies the attributes and parameters that are specific to the RetrievalProfile class.

9.1.4.5 Unless otherwise specified, all attributes and parameters in Table 9-4 are mandatory with cardinality 1.

Table 9-4: Class RetrievalProfile Attributes and Parameters

Attribute/Parameter	Description	DataType	Data Units
retrievalProfInstNo	The Retrieval Profile instance number uniquely identifies an instance of the Retrieval Profile class within the context of the Service Agreement.	Positive Integer	n/a
retrievalProfInstLabel	The Retrieval Profile instance label is an optional parameter that allows the Retrieval Profile instance to have a more human-readable “name”. The contents of this parameter are not subject to any standardization.	String1024	n/a

9.1.4.6 An instance of the RetrievalProfile class shall contain one instance of a specialization of the ReturnOfflineDataStore abstract class.

9.1.5 CLASS ReturnOfflineDataStore (Abstract)

9.1.5.1 The ReturnOfflineDataStore abstract class is a specialization of the ServiceComponentProfile abstract class (see **Error! Reference source not found.**).

9.1.5.2 The ReturnOfflineDataStore class has no parameters of its own. It serves as a parent class for Service Component Profile specializations associated with return specializations of the Offline Data Storage Abstract Service Component, such that any of those specializations can be substituted for the abstract ReturnOfflineDataStore class in a RetrievalProfile object.

NOTE - Return Offline Data Storage SCs are root SCs in Retrieval configurations.

9.1.6 CLASS AccessorServiceComponent (Abstract)

9.1.6.1 The AccessorServiceComponent abstract class is a specialization of the ServiceComponentProfile abstract class (see **Error! Reference source not found.**).

9.1.6.2 The AccessorServiceComponent class has no parameters of its own. It serves as a parent class for the Service Component Profile specializations associated with Abstract Service Component other than the Aperture, SLS Radiometric Data Production, and Service Management Function SCs, which have their own abstract parent classes (see xxx, yyy, and zzz, respectively).

9.1.7 CLASS ForwardOfflineProfile

9.1.7.1 The ForwardOfflineProfile class is a specialization of the ConfigurationProfileContents abstract class (9.1.3).

9.1.7.2 Table 9-5 specifies the attributes and parameters that are specific to the ForwardOfflineProfile class.

9.1.7.3 Unless otherwise specified, all attributes and parameters in Table 9-5 are mandatory with cardinality 1.

Table 9-5: Class ForwardOfflineProfile Attributes and Parameters

Attribute/Parameter	Description	DataType	Data Units
fwdOfflineProfInstNo	The Forward Offline Profile instance number uniquely identifies an instance of the Forward Offline Profile class within the context of the Service Agreement.	Positive Integer	n/a

DRAFT TECHNICAL NOTE CONCERNING THE FUNCTIONAL RESOURCE REFERENCE
MODEL

Attribute/Parameter	Description	DataType	Data Units
fwdOfflineProfInstLabel	The Forward Offline Profile instance label is an optional parameter that allows the Space Forward Offline Profile instance to have a more human-readable “name”. The contents of this parameter are not subject to any standardization.	String1024	n/a

9.1.7.4 An instance of the ForwardOfflineProfile class shall contain one instance of a specialization of the ForwardOfflineDataStore abstract class.

9.1.8 CLASS ForwardOfflineDataStore (Abstract)

9.1.8.1 The ForwardOfflineDataStore abstract class is a specialization of the ServiceComponentProfile abstract class (see **Error! Reference source not found.**).

9.1.8.2 The ForwardOfflineDataStore class has no parameters of its own. It serves as a parent class for the Service Component Profile specializations associated with forward specializations of the Offline Data Storage Abstract Service Component, such that any of those specializations can be substituted for the abstract ForwardOfflineDataStore class in a ForwardOfflineProfile object.

NOTE - Forward Offline Data Storage SCs are root SCs in Forward Offline configurations.

9.1.9 CLASS ServiceManagementFunctionProfile

9.1.9.1 The ServiceManagementFunctionProfile class is a specialization of the ConfigurationProfileContents abstract class (9.1.3).

9.1.9.2 Table 9-6 specifies the attributes and parameters that are specific to the ServiceManagementFunctionProfile class.

9.1.9.3 Unless otherwise specified, all attributes and parameters in Table 9-6 are mandatory with cardinality 1.

Table 9-6: Class ServiceManagementFunctionProfile Attributes and Parameters

Attribute/Parameter	Description	DataType	Data Units
---------------------	-------------	----------	------------

DRAFT TECHNICAL NOTE CONCERNING THE FUNCTIONAL RESOURCE REFERENCE
MODEL

Attribute/Parameter	Description	DataType	Data Units
svcMgmtFuncProfInstNo	The Service Management Function Profile instance number uniquely identifies an instance of the Service Management Function Profile class within the context of the Service Agreement.	Positive Integer	n/a
svcMgmtFuncProfInstLabel	The Service Management Function Profile instance label is an optional parameter that allows the Service Management Function Profile instance to have a more human-readable “name”. The contents of this parameter are not subject to any standardization.	String1024	n/a

9.1.9.4 An instance of the ServiceManagementFunctionProfile class shall contain one or more instances of specializations of the ServiceManagementFunction abstract class.

9.1.10 CLASS ServiceManagementFunction (Abstract)

9.1.10.1 The ServiceManagementFunction abstract class is a specialization of the ConfigurationProfileContents abstract class (see 9.1.3).

9.1.10.2 The ServiceManagementFunction class has no parameters of its own. It serves as a parent class for the Service Component Profile specializations associated with the Service Management Functions Abstract Service Component.

9.1.11 CLASS FUNCTIONALRESOURCEPROFILE

NOTE - An instance of the FunctionalResourceProfile class specifies the specific values of parameters that are permitted in this FunctionalResourceProfile instance.

9.1.11.1 The FunctionalResourceProfile class is a mandatory abstract class. Actual Configuration Profiles are populated with Service Component-specific specializations of the FunctionalResourceProfile class. The core specializations of the FunctionalResourceProfile class are defined in section **Error! Reference source not found.**

9.1.11.2 Table 9-7 specifies the attributes and parameters that are present in each specialization of the FunctionalResourceProfile abstract class. *Attributes* are properties of the specialized class itself – their values are fixed for each specialization. Attributes are identified by the notation “[attr]” following the name.

9.1.11.3 Unless otherwise specified, all attributes and parameters in Table 9-7 are mandatory with cardinality 1.

Table 9-7: Class FunctionalResourceProfile Attributes and Parameters

Attribute/Parameter	Description	DataType	Data Units
functionalResourceTypeOid [attr]	The Object Identifier of the Functional Resource type for which the FunctionalResourceProfile is specialized. The Functional Resource type OIDs are registered with SANA in the XYZ registry.	OID.	n/a
functResTypeClassifier [attr]	The Functional Resource type classifier attribute is an optional string-valued attribute that provides a more human-readable version of the functionalResourceTypeOid. If this attribute is present, it must contain the SANA-registered name for the Functional Resource type OID.	String32	n/a
functResProfInstNo	The Functional Resource Profile instance number uniquely identifies a Functional Resource Profile instance within the context of the Service Agreement. This instance number allows multiple Functional Resource Profiles to exist for the same Functional Resource Type..	Positive Integer	n/a
functResProfInstLabel	The Functional Resource Profile instance label is an optional parameter that allows the Functional Resource Profile instance to contain a more human-readable “name” for the Functional Resource Profile instance. The contents of this parameter are not subject to any standardization.	String1024	n/a
functResAgrInstNoRef	The Functional Resource Agreement instance number reference identifies the Functional Resource Agreement instance that specifies the constraints on the parameters of this Functional Resource Profile instance.	Positive Integer	n/a
isConfigured	The isConfigured parameter of a Functional Resource Profile is used to remove the FR from a Configuration Profile for a specific Service Package by re-specifying the value of that isConfigured parameter value to ‘false’.	Boolean (default = ‘true’)	n/a

9.1.11.4 Instance of specializations of the FunctionalResourceProfile abstract class may contain instances of other specializations of the FunctionalResourceProfile abstract class. The permitted combinations of containment are specific to each ServiceComponentProfile specialization and are defined in section **Error! Reference source not found.**

9.1.11.5 Every specialization of the FunctionalResourceProfile abstract class shall contain:

- a. One or more instances of the ConfigurationParameter class, as specified in 8.2.5. The number of instances of the ConfigurationParameter class that are contained by a specialization of the FunctionalResourceProfile abstract class is specific to the specialization and is defined in section **Error! Reference source not found.**;
- b. Zero or more instances of specializations of the Sap abstract class;
- c. Zero or more instances of specializations of the ProvidedInterface class; and
- d. Zero or more instances of specializations of the RequiredInterface abstract class.

9.1.12 CLASS Sap (Abstract)

9.1.12.1 The Sap class is an optional abstract class. Specializations of the FunctionalResourceProfile class may or may not have SAPs, depending on the particular specialization.

9.1.12.2 Each Sap class is defined for a service association type. The core specializations of the service association types and the corresponding specializations of the Sap abstract class are defined in section **Error! Reference source not found.**

9.1.12.3 The Sap abstract class serves as the parent class for specialized SAPs that contain specializations of the AccessorServiceComponent abstract class.

9.1.12.4 Table 9-8 specifies the parameters that are present in each specialization of the Sap abstract class.

Table 9-8: Class Sap Parameters

Parameter	Description	DataType	Data Units
isConfigured	The isConfigured parameter of a SAP is used to remove the SAP and all contained Accessor Service Components from a Configuration Profile for a specific Service Package by re-specifying the value of that isConfigured parameter value to 'false'.	Boolean (default = 'true')	n/a

9.1.13 CLASS PROVIDEDINTERFACE (ABSTRACT)

9.1.13.1 The ProvidedInterface class is an optional abstract class. Specializations of the FunctionalResourceProfile class may or may not have Provided Interfaces, depending on the

particular specialization. The core specializations of the ProvidedInterface abstract class are defined in section **Error! Reference source not found.**

9.1.13.2 Table 9-9 specifies the attributes and parameters that are present in each specialization of the ProvidedInterface abstract class. *Attributes* are properties of the specialized class itself – their values are fixed for each specialization. Attributes are identified by the notation “[attr]” following the name.

9.1.13.3 Unless otherwise specified, all attributes and parameters in Table 9-9 are mandatory with cardinality 1.

Table 9-9: Class ProvidedInterface Attributes and Parameters

Attribute/Parameter	Description	DataType	Data Units
ifTypeOid [attr]	The Object Identifier of the interface type for which the Provided Interface is specialized. The interface type OIDs are registered with SANA in the XYZ registry.	OID.	n/a
ifTypeClassifier [attr]	The interface type classifier attribute is an optional string-valued attribute that provides a more human-readable version of the ifTypeOid. If this attribute is present, it must contain the SANA-registered name for the provided interface type.	String32	n/a
provIfInstNo	The provided interface instance number uniquely identifies a provided interface instance within the context of the Service Agreement. This instance number allows multiple Service Component Profiles to contain provided interface instances of a provided interface type, and the same Service Component Profile to contain multiple instances of the same provided instance type (if appropriate to the functionality of the Service Component Profile).	Positive Integer	n/a
provIfInstLabel	The provided interface instance label is an optional parameter that allows the provided interface instance to contain a more human-readable “name”. The contents of this parameter are not subject to any standardization.	String1024	n/a

DRAFT TECHNICAL NOTE CONCERNING THE FUNCTIONAL RESOURCE REFERENCE
MODEL

Attribute/Parameter	Description	DataType	Data Units
isConfigured	The isConfigured parameter of a Provided Interface is used to remove the interface from a Configuration Profile for a specific Service Package by re-specifying the value of that isConfigured parameter value to 'false'.	Boolean (default = 'true')	n/a

NOTE - For purposes of cross-referencing by a RequiredInterface object, only the provIfInstNo is needed, because of the uniqueness within the ConfigurationProfileContents instance. The ifOidType attribute is needed to support re-specification of the "resourcePresent" parameter for the required interface instance, in case that required interface instance is not needed in the Service Package being requested.

9.1.14 CLASS RequiredInterface (Abstract)

9.1.14.1 The RequiredInterface class is an optional abstract class. Specializations of the FunctionalResourceProfile class may or may not have Required Interfaces, depending on the particular specialization. The core specializations of the RequiredInterface abstract class are defined in section **Error! Reference source not found.**

9.1.14.2 Table 9-10 specifies the attributes and parameters that are present in each specialization of the RequiredInterface abstract class. *Attributes* are properties of the specialized class itself – their values are fixed for each specialization. Attributes are identified by the notation "[attr]" following the name.

9.1.14.3 Unless otherwise specified, all attributes and parameters in Table 9-10 are mandatory with cardinality 1.

Table 9-10: Class RequiredInterface Attributes and Parameters

Attribute/Parameter	Description	DataType	Data Units
ifTypeOid [attr]	The Object Identifier of the interface type for which the Required Interface is specialized. The interface type OIDs are registered with SANA in the XYZ registry.	OID.	n/a

DRAFT TECHNICAL NOTE CONCERNING THE FUNCTIONAL RESOURCE REFERENCE
MODEL

Attribute/Parameter	Description	DataType	Data Units
ifTypeClassifier [attr]	The interface type classifier attribute is an optional string-valued attribute that provides a more human-readable version of the ifTypeOid. If this attribute is present, it must contain the SANA-registered name for the required interface type.	String32	n/a
reqdIfInstNo	<p>The required interface instance number uniquely identifies a required interface instance within the context of the Service Agreement. This instance number allows multiple Service Component Profiles to contain required interface instances of a required interface type, and the same Service Component Profile to contain multiple instances of the same required instance type (if appropriate to the functionality of the Service Component Profile).</p> <p>The provided interface instance number uniquely identifies a provided interface instance within the context of the Service Agreement. This instance number allows multiple Service Component Profiles to contain provided interface instances of a provided interface type, and the same Service Component Profile to contain multiple instances of the same provided instance type (if appropriate to the functionality of the Service Component Profile).</p>	Positive Integer	n/a
reqdIfInstLabel	The required interface instance label is an optional parameter that allows the required interface instance to contain a more human-readable “name”. The contents of this parameter are not subject to any standardization.	String1024	n/a
provIfInstNoRef	The provided interface instance number reference links the required interface instance to the appropriate peer provided interface instance	Positive Integer	n/a
isConfigured	The isConfigured parameter of a Required Interface is used to remove the interface from a Configuration Profile for a specific Service Package by re-specifying the value of that isConfigured parameter value to ‘false’.	Boolean (default = ‘true’)	n/a

DRAFT TECHNICAL NOTE CONCERNING THE FUNCTIONAL RESOURCE REFERENCE
MODEL

NOTE - For purposes of cross-referencing to a ProvidedInterface object, only the provIfInstNo is needed, because of the uniqueness within the ConfigurationProfileContents instance. The ifOidType attribute and reqdIfInstNo parameter are needed to support re-specification of the “resourcePresent” parameter for the IF instance, in case that IF instance is not needed in the Service Package being requested.

ANNEX A

ACRONYMS AND ABBREVIATIONS

ANNEX B IDENTIFIED FUTURE SERVICE COMPONENTS

[INFORMATIVE]

This section only lists recommendations / work in progress relevant to Service Catalog #1. Space internetworking and Service Catalog #2 will probably cause significantly more complication.

B1 EXISTING RECOMMENDATIONS

B1.1 415.1-B-1 DATA TRANSMISSION AND PN RANGING FOR 2 GHZ CDMA LINK VIA DATA RELAY SATELLITE

Based on TDRSS systems in use. Defines the physical channel layer, in forward and return directions. Includes convolutional coding (with no manageable parameters). No specific constraints (?) on data link layer; the SN supports TC, AOS, TM. Question: Are TM and TC sync and non-convolutional coding used entirely as is over TDRSS? Including the PLOP?

It seems reasonable to assume that 415.1 will not be combined with any other physical channel – if forward and return channels are part of the same service package, then both or neither use 415.1.

B1.2 131.2-B-1 FLEXIBLE ADVANCED CODING AND MODULATION SCHEME FOR HIGH RATE TELEMETRY APPLICATIONS

Defines both physical channel and synch & coding layers, return only. Compatible with TM, AOS transfer frames.

B1.3 131.3-B-1 SPACE LINK PROTOCOLS OVER ETSI DVB-S2 STANDARD

Defines both physical channel and synch & coding layers as a profile of DVB-S2, return only. Compatible with TM, AOS transfer frames. Minimal managed parameters since many of the details are covered by the single “MODCOD” parameter which selects a modulation and coding combination.

Both 131.1 and 131.2 seem most likely to be combined with a 401 forward physical channel. They both seem unlikely to carry return ranging symbols (tbc by SLS experts?) but presumably could still be used to obtain antenna angles and one-way doppler.

B2 RECOMMENDATIONS IN WORK

B2.1 OPTICAL COMMUNICATION (SLS-OPT)

Expects to define both physical and synch and coding layers, in separate BBs (currently listed for 2017). Two “regimes” are foreseen (low and high photon flux). Not clear to me how different they may look in terms of managed parameters. Both forward and return seem

to be expected; forward 401 RF and return optical also seems a plausible combination. Expected to be compatible with AOS and TM data link protocols.

There may also be a Blue or Magenta Book(s) for Real-Time Weather and Atmospheric Characterization Data – not clear whether this represents a candidate for Service Mgmt or not, nor what it would look like if it is.

B2.2 NEXT GENERATION UPLINK NGU (SLS-NGU)

Green Book 230.2-G Next Generation Uplink is apparently awaiting publication. BB currently slated for 2017.

This seems to be largely concerned with sync and coding and selection of bandwidth-efficient modulation schemes, to be compatible with TC, forward AOS, or both. Not clear whether a single spec like ACM, or additions to 401 and a synch & coding book, are anticipated.

B2.3 NEXT GENERATION SPACE LINK PROTOCOL NGSLP (SLS-SLP)

A replacement for TC, TM, AOS, and Proximity-1 space data link protocols. More flexible, variable-length frame, supporting almost everything the existing SLPs do in a single spec. Expressly decoupled from coding considerations, but presumably incompatible in the general case with any sync & coding scheme which requires a fixed-length frame (such as TM/AOS) unless it is adapted to use a fixed-length slicing scheme instead (under consideration).

BB and GB also currently shown as 2017, not yet approved.

B3 UPDATES TO CURRENTLY COVERED RECOMMENDATIONS

- SLS-CS WG selecting new codes for TC uplink to upgrade 231.0-B (TC Coding).
- SLS-CS WG will start draft pink sheets to 131.0-B (TM Coding) for Fall 2014 to introduce slicing
- Will SDLS have impact on TM/TC/AOS SLP management – BBs will be updated?

B4 SUMMARY

The table shows which new FG specializations we might reasonably expect to appear from each of the current and potential future recommendations.

FG		Forward			Return		
Recom.	Aperture	Physical	Code&Sync	SDLP	Physical	Code&Sync	SDLP
415.1		Y			Y		
131.2					Y	Y	
131.3					Y	Y	
Optical	Y	Y	Y		Y	Y	
NGU		?	Y				
NGSLP				Y			Y

ANNEX C

REFERENCE BOOKMARKS (TO BE DELETED)

- [1] nRef_910x4_CSRM
- [2] nRef_911x1RAF
- [3] nRef_911x2_RCF
- [4] nRef_921x1CstsSFW
- [32] nRef231x0_TcSync
- [6] nRef_131x0_TmSync
- [7] nRef_922_RUFT
- [8] nRef_922x2_TD_CSTS
- [9] nRef_IOAG1
- [10] nRef_922x1_MD_CSTS
- [11] nRef_DoatTN
- [12] nRef_902x0_ESCCS_SM
- [13] nRef_901x0_SCCS_ADD
- [14] nRef_910x11_SCCS_SM
- [15] nRef_902x_SCCS_SM_SA_CP
- [16] nRef_IOAG_SC2
- [17] nRef_232x0_TC_SDLP
- [18] nRef_732x0_AOS_SDLP
- [19] nRef_132x0_TM_SDLP
- [20] nRef_133x0_SPP
- [21] nRef_232x1_COP_1
- [22] nRef_133x1_Encap
- [23] nRef_401_RF_Mod

DRAFT TECHNICAL NOTE CONCERNING THE FUNCTIONAL RESOURCE REFERENCE
MODEL

- [24] nRef_414x1_PN_ranging
- [25] nRef_415x1_CDMA
- [26] nRef_727x0_CFDP
- [27] nRef_912x1_CLTU
- [28] nRef_912x3_FSP
- [29] nRef_911x5_ROCF
- [30] nRef_734x0_DTN
- [31] nRef_702x1_IP_Over_CCSDS
- [32] nRef_506x1_DDOR_Fmt

DRAFT TECHNICAL NOTE CONCERNING THE FUNCTIONAL RESOURCE REFERENCE
MODEL